

Routing/Mapping of Payments and Ancillary System Transactions

Version 3.0 / 29th October 2010

Selected Examples

Content

Versioning

No.	Date	Comments	Status
0.1	21-12-2005	First draft	Closed
0.2	27-03-2006	AS transactions (2.4) added	Closed
0.3	31-03-2006	Direct Debits (2.3) added	Closed
0.4	05-04-2006	Liquidity transfer by co-manager (2.2.5) added	Closed
0.5	04-05-2006	Liquidity transfer (2.2) completed	Closed
0.6	05-05-2006	Credit transfer (2.1) added	Closed
0.7	30-05-2006	Adaptations added	Closed
1.0	27-07-2006	Changes made	Closed
1.1	14-08-2006	Corrections for 2.1	Closed
1.2	11-09-2006	Corrections for 2.1 and 2.3	Closed
1.3	12-01-2007	Revision of 2.4 and adoption to UDFS v2.2	Closed
1.4	08-02-2007	Changes made	Closed
1.5	12-04-2007	Liquidity transfer with PHA (2.2) Connected payments Back-up payments	Closed
2.0	31-03-2008	Deletion of information related to the migration phase, Backup payments (2.5)	Closed
3.0	29-10-2010	Credit transfers sent by SWIFT-based PM direct participant to Internet-based PM participant added (2.1.1) Credit transfers ordered by Internet-based PM participant to SWIFT-based PM direct participant added (2.1.1) Credit transfers ordered by Internet-based PM participant to Internet-based PM participant added (2.1.1) Credit transfers ordered by Internet-based CB customers to SWIFT-based PM direct participants added (2.1.1) FIN payments sent by SWIFT-based CB customers to Internet-based PM direct participants added (2.1.1) Credit transfers ordered by Internet-based CB customers to Internet-based PM participants (2.1.1) added	Open

Content

		<p>Credit transfers ordered by Internet-based CB customers to Indirect PM participants added (2.1.2)</p> <p>Credit transfers ordered by Internet-based PM participant to SWIFT-based CB customer added (2.1.4)</p> <p>Credit transfers ordered by Internet-based PM participant to Internet-based CB customer added (2.1.4)</p> <p>FIN payments sent by SWIFT -based PM participant to Internet-based CB customer added (2.1.4)</p> <p>Credit transfers ordered by Internet-based CB customers to SWIFT-based CB customers added. Same CB (2.1.4)</p> <p>FIN payments sent by SWIFT-based CB customers to Internet-based CB customers added. Same CB (2.1.4)</p> <p>Credit transfers ordered by Internet-based CB customers to Internet-based CB customers added. Same CB (2.1.4)</p> <p>Credit transfers ordered by Internet-based CB customers to SWIFT-based CB customers added. Different CB (2.1.4)</p> <p>FIN payments sent by SWIFT-based CB customers to Internet-based CB customers added. Different CB (2.1.4)</p> <p>Credit transfers ordered by Internet-based CB customers to Internet-based CB customers added. Different CB (2.1.4)</p> <p>Liquidity Transfers from PM to HAM added (2.2.1)</p> <ul style="list-style-type: none"> • LT from SWIFT-based PM participant to HAM via ICM • LT from PM participant to HAM via SWIFT FIN payment • LT from Internet-based PM participant to HAM <p>Liquidity transfers via ICM from HAM account holders to PM direct participants added (2.2.1)</p> <ul style="list-style-type: none"> • LT from HAM account to RTGS account. Same participant. • LT from HAM account to RTGS account. Different participant. Same CB. • LT from HAM account to RTGS account. Different 	
--	--	--	--

		<p>participant. Different CB.</p> <p>Liquidity transfers via ICM from HAM account holders (2.2.1)</p> <ul style="list-style-type: none"> • LT from co-managed to HAM account holder. Same CB • LT ordered by co-manager (co-managed debited) to HAM account holder. Same CB. <p>Payments sent by co-managed HAM account holder to the RTGS account of the co-manager added (2.2.1)</p> <ul style="list-style-type: none"> • Via SWIFT. Same CB. • Via ICM. Same CB. • Different CB (not explained) <p>Liquidity transfers with PHA updated (2.2.2)</p> <ul style="list-style-type: none"> • LT from PHA to PM via SWIFT updated • LT from PHA to PM via ICM added • LT from a PHA to a indirect PM participant deleted • LT from direct PM participant to PHA via SWIFT updated • LT from indirect PM participant to PHA deleted • LT from direct PM participant to PHA via ICM added • LT from direct PM participant to PHA at the EoD added <p>Liquidity transfer between group of account members added (2.2.3)</p> <ul style="list-style-type: none"> • LT between group of account members via ICM added <p>Adaptation to CCBM2 added (2.4.6)</p> <ul style="list-style-type: none"> • Automatic increase of blocked liquidity – connected payment initiated by CCBM2. • Automatic increase of blocked liquidity – mandated payment initiated by CCBM2. <p>Cross-DvP settlement added (2.4.7)</p> <p>EBA BIC related to EURO 1 for back-up payments modified (2.5.2)</p>	
--	--	--	--

Note: This document was drafted by Banca d'Italia, Banque de France and Deutsche Bundesbank (3CB) and is based on the User Detailed Functional Specifications (UDFS), version 4.0, books I, II and IV.

- 1 INTRODUCTION..... 9**

- 2 FLOW OF PAYMENTS/TRANSACTIONS 11**
 - 2.1 CREDIT TRANSFER..... 11**
 - 2.1.1 CREDIT TRANSFER TO A DIRECT PARTICIPANT..... 11
 - 2.1.1.1 From SWIFT-based PM participant to SWIFT-based PM participant..... 11
 - 2.1.1.2 From indirect participant to SWIFT-based PM participant..... 13
 - 2.1.1.3 From SWIFT-based direct PM participant to Internet based participant..... 15
 - 2.1.1.4 From Internet based participant to SWIFT based PM participant..... 19
 - 2.1.1.5 From Internet based participant to Internet based participant 23
 - 2.1.1.6 From CB customer to SWIFT-based participant..... 25
 - 2.1.1.7 From SWIFT-based CB customers to Internet-based direct PM participant. 28
 - 2.1.1.8 From Internet-based CB customers to SWIFT-based participant..... 31
 - 2.1.1.9 From Internet-based CB customers to Internet-based participant..... 33
 - 2.1.2 CREDIT TRANSFER TO AN INDIRECT PARTICIPANT 35
 - 2.1.2.1 From CI as direct participant 35
 - 2.1.2.2 From CI as indirect participant 37
 - 2.1.2.3 From SWIFT-based CB customers 39
 - 2.1.2.4 From Internet-based CB customers 41
 - 2.1.3 CREDIT TRANSFER TO A HAM PARTICIPANT 43
 - 2.1.3.1 From CI as direct participant 43
 - 2.1.3.2 From CI as indirect participant 46
 - 2.1.3.3 From CB customers 48
 - 2.1.4 CREDIT TRANSFER TO A CB CUSTOMER..... 49
 - 2.1.4.1 From SWIFT-based PM participant to SWIFT-based CB customer 49
 - 2.1.4.2 From CI as indirect participant to SWIFT-based CB customer..... 52
 - 2.1.4.3 From Internet-based PM participant to Internet-based CB customer 55
 - 2.1.4.4 From Internet-based PM participant to SWIFT-based CB customer..... 59
 - 2.1.4.5 From SWIFT-based CB customer to SWIFT-based CB Customer. Same CB 62
 - 2.1.4.6 From Internet-based CB customer to SWIFT-based CB customer. Same CB..... 64
 - 2.1.4.7 From SWIFT-based CB customer to Internet-based CB customer. Same CB..... 66
 - 2.1.4.8 From Internet-based CB customer to Internet-based CB customer. Same CB..... 68
 - 2.1.4.9 From SWIFT-based CB customer to SWIFT-based CB customer. Different CB.... 69
 - 2.1.4.10 From Internet-based CB customer to SWIFT-based CB customer. Different CB.... 72
 - 2.1.4.11 From SWIFT-based CB customer to Internet-based CB customer. Different CB.... 75
 - 2.1.4.12 From Internet-based CB customer to Internet-based CB customer. Different CB... 78
 - 2.2 LIQUIDITY TRANSFER/INTERBANK TRANSFER 80**
 - 2.2.1 LIQUIDITY TRANSFER WITH HAM..... 80
 - 2.2.1.1 Liquidity transfer from SWIFT-based PM participant to HAM via ICM..... 80

Content

- 2.2.1.2 Liquidity transfer from PM participant to HAM via SWIFT FIN payment..... 83
- 2.2.1.3 Liquidity transfer from Internet-based PM participant to HAM..... 86
- 2.2.1.4 Liquidity transfer/Interbank tranfer from HAM account holder to a direct PM Participant 88
- 2.2.1.5 Liquidity transfer/Interbank tranfer from HAM account holder to a direct PM Participant ordered via ICM..... 97
- 2.2.1.6 Interbank transfer from HAM account holder to HAM account holder 103
- 2.2.1.7 Liquidity transfer between “HAM accounts” initiated by a co-manager 109
- 2.2.1.8 Interbank transfer from “HAM account” to RTGS account of a direct participant initiated by a co-manager..... 115
- 2.2.1.9 Interbank transfer from “HAM account” to the RTGS account of the co-manager initiated by the co-manager..... 121
- 2.2.1.10 Interbank transfer from “HAM account” to the RTGS account of the co-manager initiated by the co-managed. Same CB..... 128
- 2.2.1.11 Interbank transfer from “HAM account” to the RTGS account of the co-manager initiated by the co-managed. Different CB. 134
- 2.2.2 LIQUIDITY TRANSFER WITH PHA 135
- 2.2.2.1 Liquidity transfer from PHA to PM via SWIFT 135
- 2.2.2.2 Liquidity transfer from PHA to PM via ICM..... 137
- 2.2.2.3 Liquidity transfer from a PHA account holder to a direct PM participant during the business day 139
- 2.2.2.4 Liquidity transfer from direct PM participant to PHA account holder via SWIFT. .. 140
- 2.2.2.5 Liquidity transfer from direct PM participant to PHA account holder via ICM. 142
- 2.2.2.6 Liquidity transfer from direct PM participant to PHA account holder at the End of Day..... 144
- 2.2.3 LIQUIDITY TRANSFER BETWEEN GROUP OF ACCOUNT MEMBERS 146
- 2.2.3.1 Liquidity transfer between group of account members via ICM..... 146
- 2.3 DIRECT DEBITS..... 148**
- 2.3.1 DEBITING A DIRECT PARTICIPANT..... 148
- 2.3.1.1 From CI as direct participant 148
- 2.3.1.2 From CI as direct participant using a second BIC 150
- 2.3.1.3 From CI as indirect participant 152
- 2.3.2 DEBITING AN INDIRECT PARTICIPANT 154
- 2.3.2.1 From CI as direct participant 154
- 2.3.2.2 From CI as direct participant using a second BIC 156
- 2.3.2.3 From CI as indirect participant 158
- 2.4 AS TRANSACTIONS..... 160**
- 2.4.1 LIQUIDITY TRANSFER..... 160
- 2.4.1.1 Debit the mirror account and credit the settlement bank account 160
- 2.4.1.2 Debit the settlement bank account and credit the mirror account 162
- 2.4.2 REAL - TIME – SETTLEMENT 165
- 2.4.3 BILATERAL SETTLEMENT 168
- 2.4.4 STANDARD MULTILATERAL SETTLEMENT 171
- 2.4.5 SIMULTANEOUS MULTILATERAL SETTLEMENT..... 174
- 2.4.6 SETTLEMENT ON DEDICATED LIQUIDITY ACCOUNT 177

Content

- 2.4.6.1 Interfaced model.....177
- 2.4.6.2 Integrated model206
- 2.4.7 CROSS-DVP: SETTLEMENT ON DEDICATED LIQUIDITY ACCOUNT216
 - 2.4.7.1 From Integrated AS to Interfaced AS216
 - 2.4.7.2 From Integrated AS to Integrated AS219
 - 2.4.7.3 From Interfaced AS to Integrated AS222
 - 2.4.7.4 From Interfaced AS to Interfaced AS225
- 2.5 BACKUP PAYMENTS.....228**
 - 2.5.1 BACKUP LUMP-SUM PAYMENT TO A DIRECT PM PARTICIPANT (INCLUDING CBs AS DIRECT PM PARTICIPANT).....228
 - 2.5.2 BACKUP CONTINGENCY PAYMENTS230
 - 2.5.2.1 Rules for CLS payments230
 - 2.5.2.2 Rules for payments to EBA related to EURO1232
 - 2.5.2.3 Rules for payments to EBA related to STEP2234

1 Introduction

This document describes addressing and routing examples of certain payments and AS transactions in the SSP.

It gives information how to handle the different use cases.

The participants (CIs, CBs, ASs and financial institutions) shall be guided through the flow of message types.

The content is structured as follows:

1. Who is the addressee of the business case (message)
2. Who is the sending participant

Usually BICs and references are used only for one business case. It is possible to make use of the same BICs in different examples with different meaning. That is why BICs and references among the examples are not consistent.

In case of MT 202/103/103+ the message types MT 103 and MT 103+ are not described in detail in the following tables unless there are any engrave differences.

Following messages are optional: MT 012, MT 900, MT 910. Therefore, they are presented by broken lines in graphic. According to the description of these message types in tables there is no claim of completeness. Therefore, some descriptions are very well prepared, but in any cases the respective messages are only mentioned.

The booking on special accounts will be offered in some special cases as additional information. For more information on these bookings have a look at the respective UDFS chapter.

SWIFT messages (e.g. settlement requests and confirmations (MT 096 and MT 097)) and internal messages will only be depicted but not described in detail since they are not delivered to the participants.

In the graphics whenever a message is described as MT202/103/103+, it is also valid for MT202 COV.

MT103 payments to Internet-based participants: fields 56a/57a, or 57a are compulsory. BIC of the Internet-based participant must be set.

BICs with 11 characters must be entered into the relevant fields when capturing payments sent by internet-based participants to internet-based participants through the ICM screen "Credit Transfer".

For example 58A: AAAAEUFF is not accepted. (Error code: Invalid sending/receiving BIC)

58A: AAAAEUFFXXX is accepted.

HAM account holders are only allowed to send MT202 simplified via SWIFT or the equivalent order via ICM (Liquidity Transfer).

Internet-based access is also available for HAM account holders. Internet-based participants can use the existing functionality "LiquidityTransfer other Accounts" to transfer liquidity from the HAM account to the PM account (both SWIFT-based and Internet-based participants).

2 Flow of payments/transactions

2.1 Credit transfer

2.1.1 Credit transfer to a direct participant

2 Flow of payments/transactions

2.1 Credit transfer

2.1.1 Credit transfer to a direct participant

2.1.1.1 From SWIFT-based PM participant to SWIFT-based PM participant

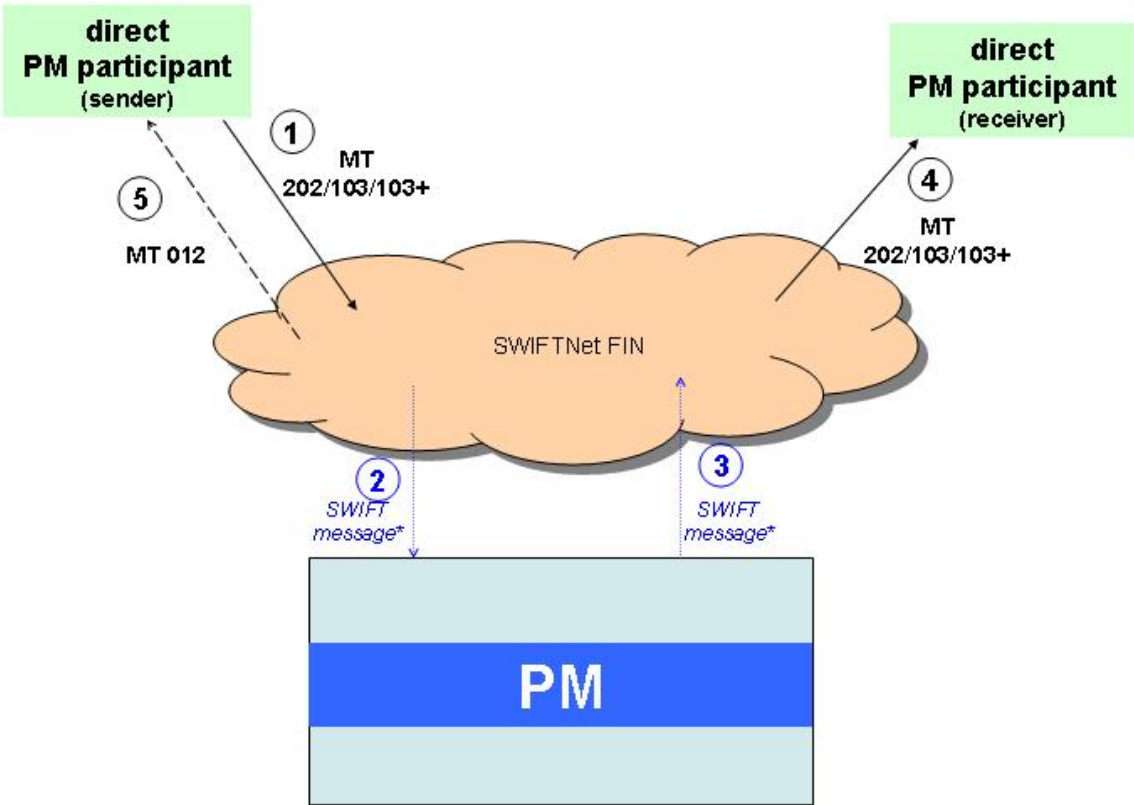

* Internal and SWIFT messages are not explained

2 Flow of payments/transactions

2.1 Credit transfer

2.1.1 Credit transfer to a direct participant

① MT 202 from direct PM participant		S: Direct PM participant (sender) R: Direct PM participant (receiver) 103: TGT (service identifier)
		20: TRN 21: Related Reference 32A: Value date, currency code and amount ... 58a: Direct PM participant (receiver) ...
④ MT 202 to direct PM participant		Message from ①
⑤ MT 012 (<i>optional</i>) from SWIFT to sender		S: SWIFT system R: Direct PM participant (sender) 175: Input time of the initial MT 202/103/103+ ① 106: Message Input Reference (MIR) of initial MT 202/103/103+ ① 108: Message User Reference (MUR) if filled, else: TRN of initial MT 202/103/103+ ① 102: SWIFT address of receiver (complete 12 character destination) 103: TGT (service identifier) 114: Payment-release-information-sender (credit and debit time, country code of sender and reference of the initial MT 202/103/103+ (field 20) ①)

2 Flow of payments/transactions

2.1 Credit transfer

2.1.1 Credit transfer to a direct participant

2.1.1.2 From indirect participant to SWIFT-based PM participant

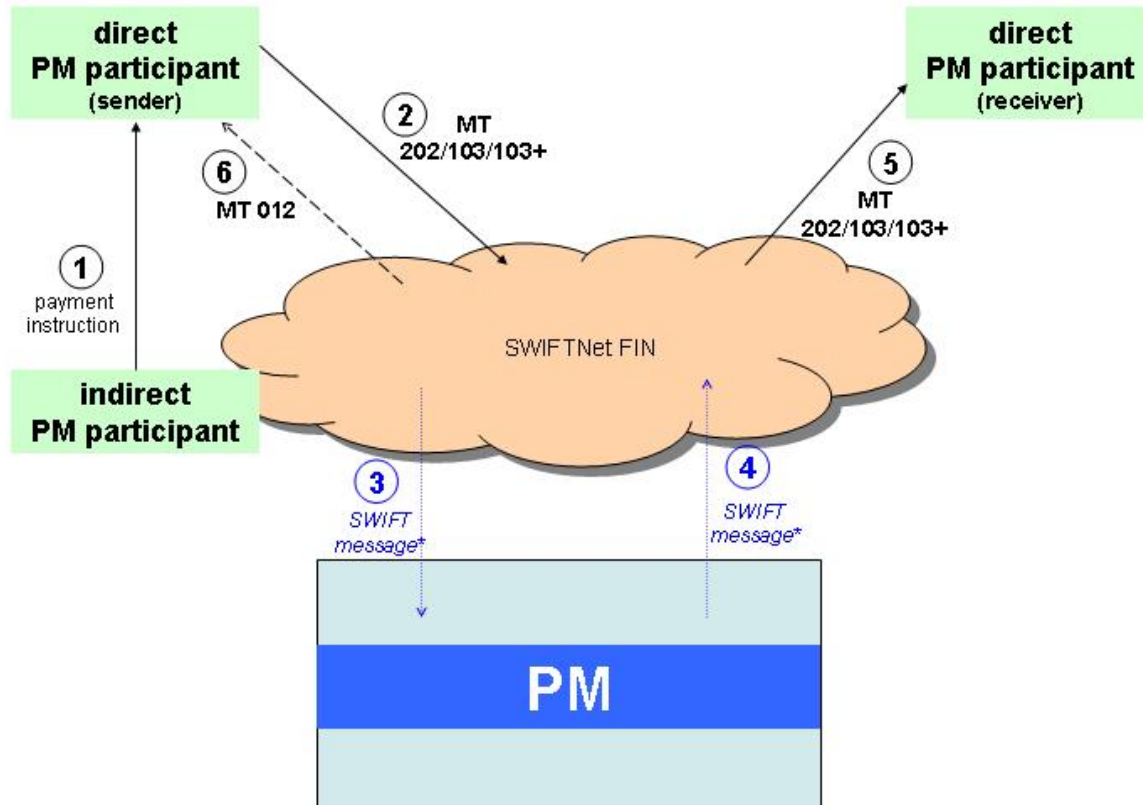

* Internal and SWIFT messages are not explained

Message	BIC of respective SSP-Module	Field entry
① payment instruction		- outside the scope of SSP -
② MT 202 from direct PM		S: Direct PM participant (sender) R: Direct PM participant (receiver) 103: TGT (service identifier)

2 Flow of payments/transactions

2.1 Credit transfer

2.1.1 Credit transfer to a direct participant

Message	BIC of respective SSP-Module	Field entry
participant		20: TRN 21: Related Reference 32A: Value date, currency code and amount ... 52a: Indirect PM participant (instructed initial MT 202/103/103+ ①) ... 58a: Direct PM participant (receiver) ...
⑤ MT 202 to direct PM participant		Message from ②
⑥ MT 012 (optional) from SWIFT to sender		S: SWIFT system R: Direct PM participant (sender)
		175: Input time of the initial MT 202/103/103+ ② 106: Message Input Reference (MIR) of the initial MT 202/103/103+ ② 108: Message User Reference (MUR) if filled, else: TRN of initial MT 202/103/103+ ② 102: SWIFT address of receiver (complete 12 character destination) 103: TGT (service identifier) 114: Payment-release-information-sender (credit and debit time, country code of sender and reference of the initial MT 202/103/103+ (field 20) ②)

2 Flow of payments/transactions

2.1 Credit transfer

2.1.1 Credit transfer to a direct participant

2.1.1.3 From SWIFT-based direct PM participant to Internet based participant

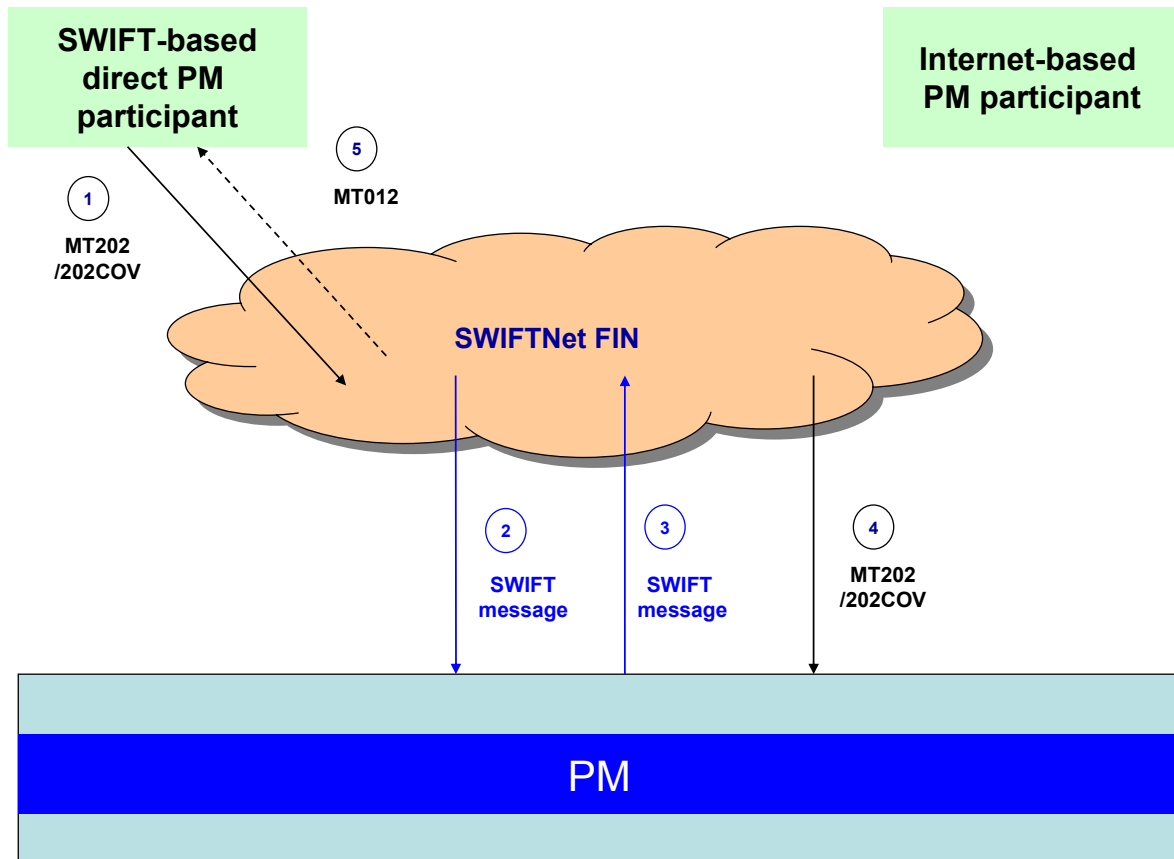

* Internal and MT096-MT097 messages are not explained

Message	BIC of respective SSP-Module	Field entry
① MT 202 from direct PM participant		S: Direct PM participant (sender) R: TRGTXEPMMLVP (receiver) 103: TGT (service identifier)
		20: TRN 21: Related Reference 32A: Value date, currency code and amount ... 58a: Internet Based participant (receiver) ...
④ MT 202		Message from ①. Assigned to PM

2 Flow of payments/transactions

2.1 Credit transfer

2.1.1 Credit transfer to a direct participant

Message	BIC of respective SSP-Module	Field entry
⑤ MT 012 (<i>optional</i>) from SWIFT to sender		S: SWIFT system R: Direct PM participant (sender)
		175: Input time of the initial MT 202/103/103+ ① 106: Message Input Reference (MIR) of initial MT 202/103/103+ ① 108: Message User Reference (MUR) if filled, else: TRN of initial MT 202/103/103+ ① 102: SWIFT address of receiver (complete 12 character destination) 103: TGT (service identifier) 114: Payment-release-information-sender (credit and debit time, country code of sender and reference of the initial MT 202/103/103+ (field 20) ①)

2 Flow of payments/transactions

2.1 Credit transfer

2.1.1 Credit transfer to a direct participant

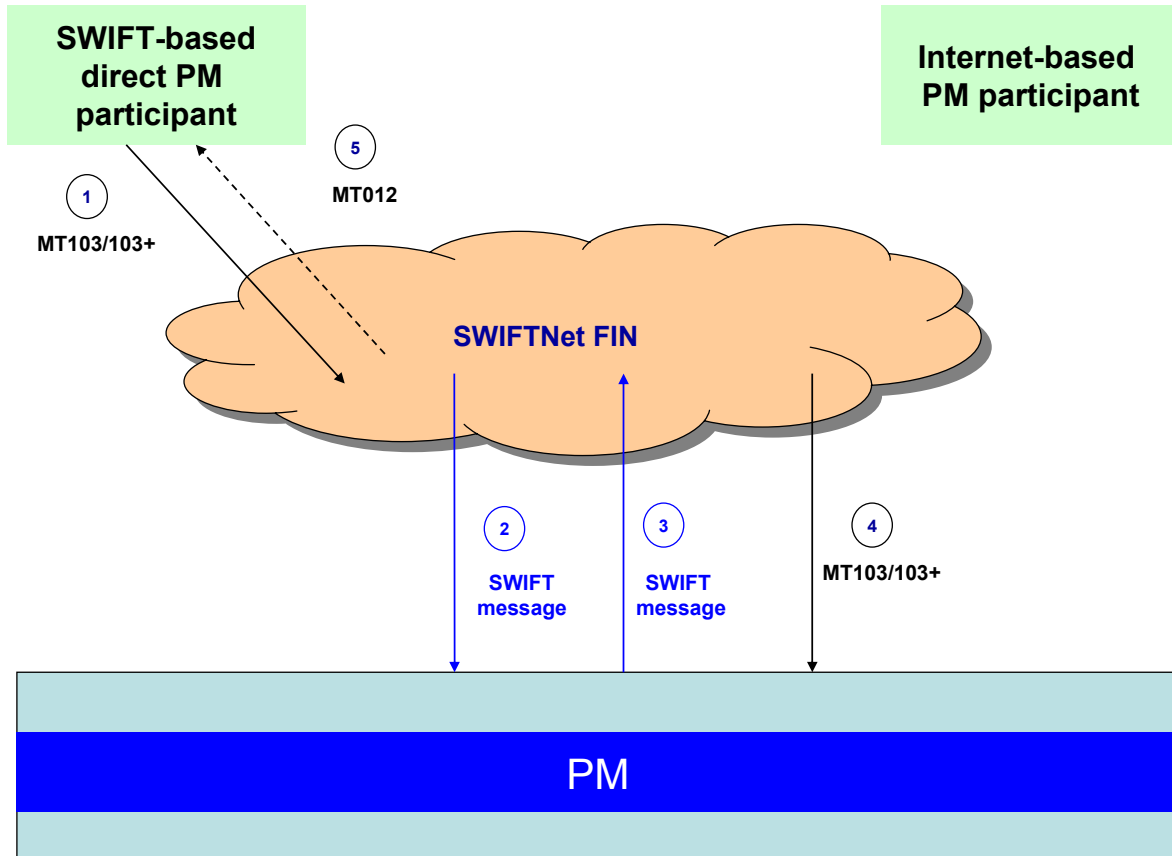

* Internal and MT096-MT097 messages are not explained

Message	BIC of respective SSP-Module	Field entry
① MT 103 from direct PM participant		S: Direct PM participant (sender) R: TRGTXEMLVP (receiver) 103: TGT (service identifier)
		20: TRN 21: Related Reference 32A: Value date, currency code and amount 56a Internet Based participant (receiver) and/or 57a Internet Based participant (receiver) 59a /1234567890 CLIENT
④ MT 103		Message from ①. Assigned to PM

2 Flow of payments/transactions

2.1 Credit transfer

2.1.1 Credit transfer to a direct participant

Message	BIC of respective SSP-Module	Field entry
⑤ MT 012 (<i>optional</i>) from SWIFT to sender		S: SWIFT system R: Direct PM participant (sender)
		175: Input time of the initial MT 202/103/103+ ① 106: Message Input Reference (MIR) of initial MT 202/103/103+ ① 108: Message User Reference (MUR) if filled, else: TRN of initial MT 202/103/103+ ① 102: SWIFT address of receiver (complete 12 character destination) 103: TGT (service identifier) 114: Payment-release-information-sender (credit and debit time, country code of sender and reference of the initial MT 202/103/103+ (field 20) ①)

2 Flow of payments/transactions

2.1 Credit transfer

2.1.1 Credit transfer to a direct participant

2.1.1.4 From Internet based participant to SWIFT based PM participant

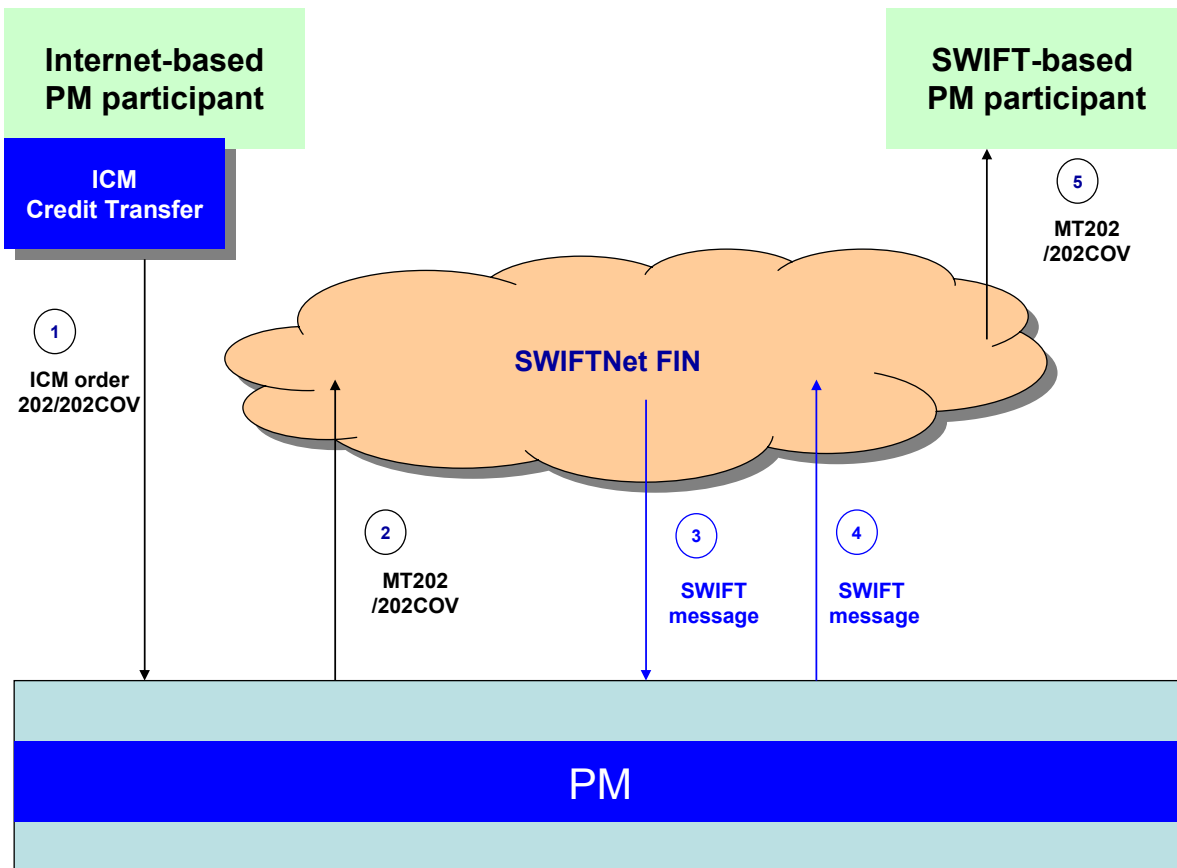

* Internal and MT096-MT097 messages are not explained

Message	BIC of respective SSP-Module	Field entry
① ICM: Enter MT 202 from Internet Based participant PM	N/A	S: N/A R: Direct PM Participant (receiver) 113: Bank Priority
		20: TRN 21: Related Reference 32A: Value date, currency code and amount ... 58a: Direct PM Participant (receiver) ...

2 Flow of payments/transactions

2.1 Credit transfer

2.1.1 Credit transfer to a direct participant

Message	BIC of respective SSP-Module	Field entry
② MT 202 from PM to SWIFT-based direct PM participant	TRGTXEPLVP	S: TRGTXEPLVP R: Direct PM participant 103: TGT (service identifier)
		20: TRN from ① 21: Related Reference from ① 32A: Value date, currency code and amount ① ... 58a: Direct PM participant from ① ...
⑤ MT 202 to SWIFT-based direct PM participant	TRGTXEPLVP	Message from ②

2 Flow of payments/transactions

2.1 Credit transfer

2.1.1 Credit transfer to a direct participant

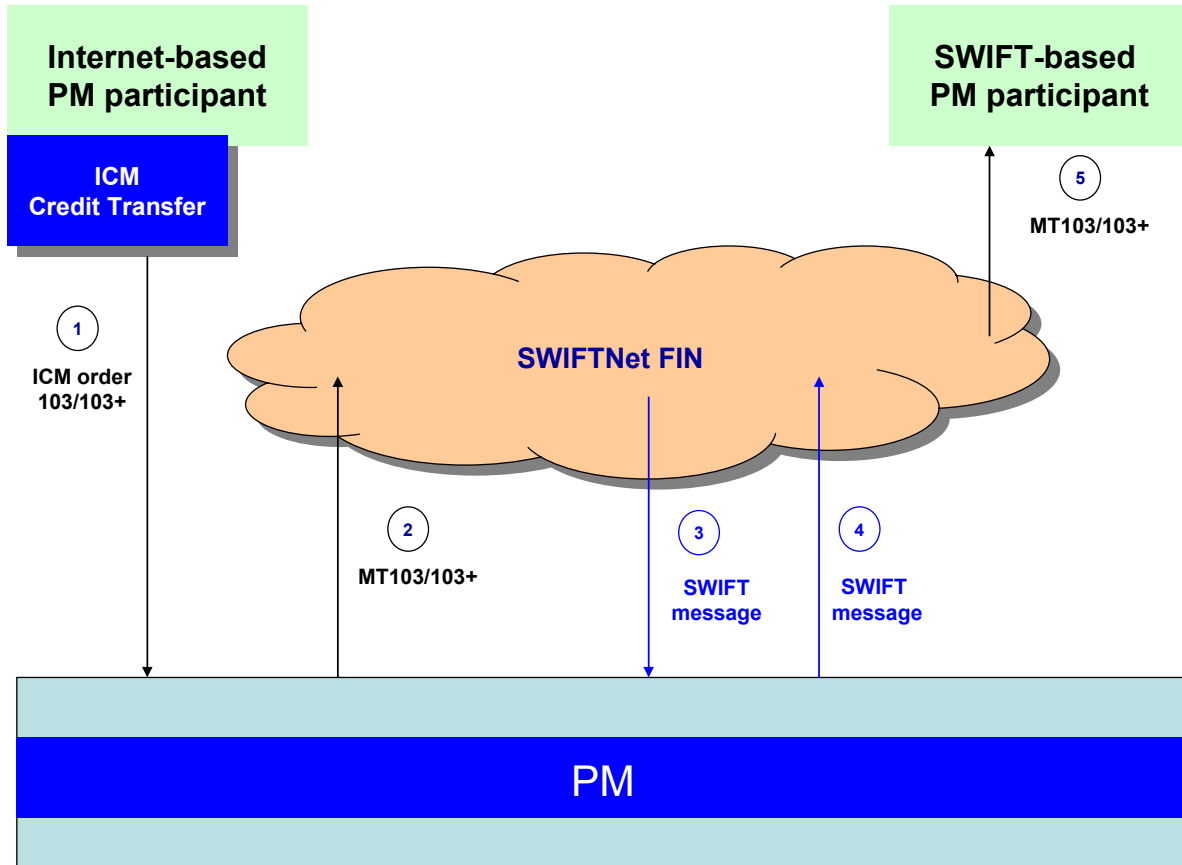

* Internal and MT096-MT097 messages are not explained

Message	BIC of respective SSP-Module	Field entry
① ICM: Enter MT 103 from Internet Based participant PM	N/A	S: N/A R: Direct PM Participant (receiver) 113: Bank Priority 20: TRN 21: Related Reference 32A: Value date, currency code and amount ... 57a: SWIFT-based PM Participant (receiver) 59a /1234567890 CLIENT
② MT 103 from PM to SWIFT-based	TRGTXEPMMLVP	S: TRGTXEPMMLVP R: Direct PM participant 103: TGT (service identifier)

2 Flow of payments/transactions

2.1 Credit transfer

2.1.1 Credit transfer to a direct participant

Message	BIC of respective SSP-Module	Field entry
		20: TRN from ① 21: Related Reference from ① 32A: Value date, currency code and amount ① ... 57a: SWIFT-based PM Participant (receiver) ① 59A: /1234567890 CLIENT from ①
⑤ MT 103 to SWIFT-based direct PM participant	TRGTXEPLVP	Message from ②

2 Flow of payments/transactions

2.1 Credit transfer

2.1.1 Credit transfer to a direct participant

2.1.1.5 From Internet based participant to Internet based participant

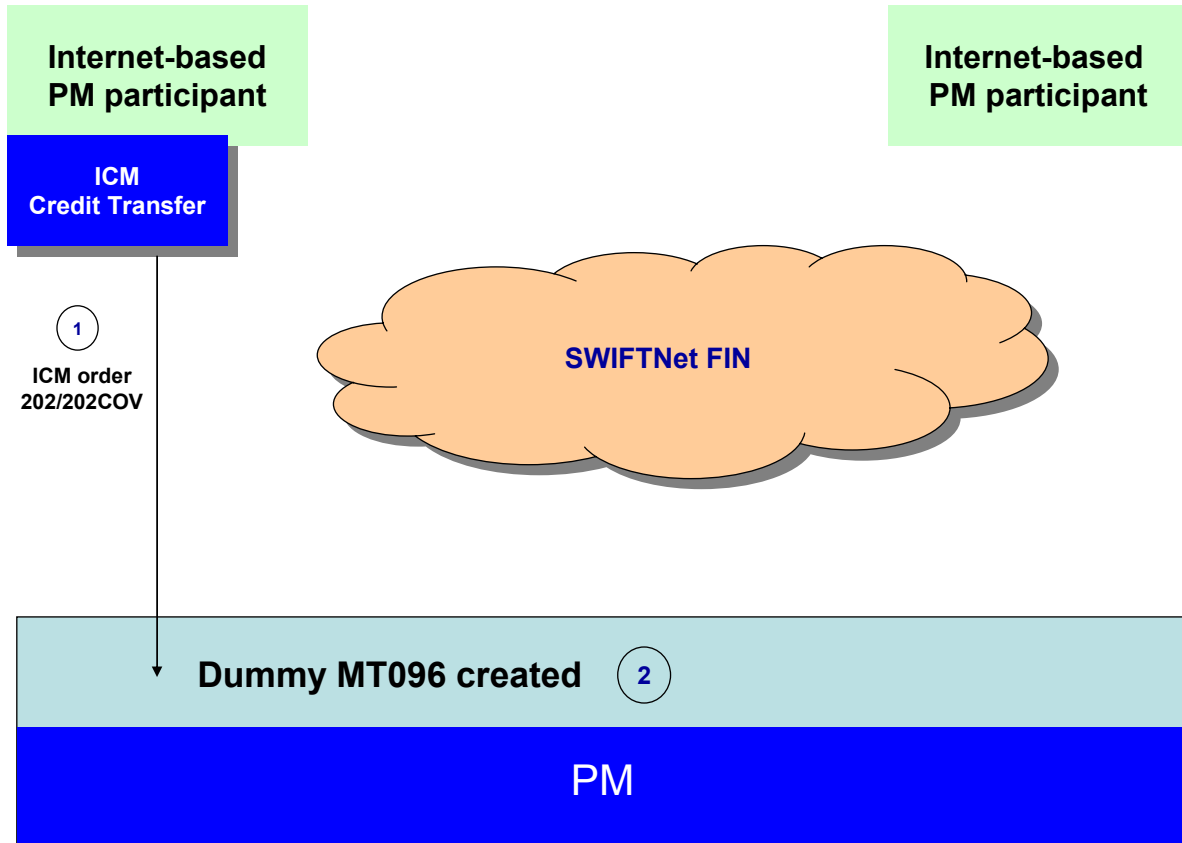

** Internal and MT096-MT097 messages are not explained*

Message	BIC of respective SSP-Module	Field entry
① ICM: Enter MT 202 from Internet Based participant PM	N/A	S: N/A R: TRGTXEPLVP 113: Banking Priority 20: TRN 21: Related Reference 32A: Value date, currency code and amount ... 58a: Internet Based Participant ...
② Dummy MT096		A dummy MT096 is created from ①. It is not sent to SWIFT

2 Flow of payments/transactions

2.1 Credit transfer

2.1.1 Credit transfer to a direct participant

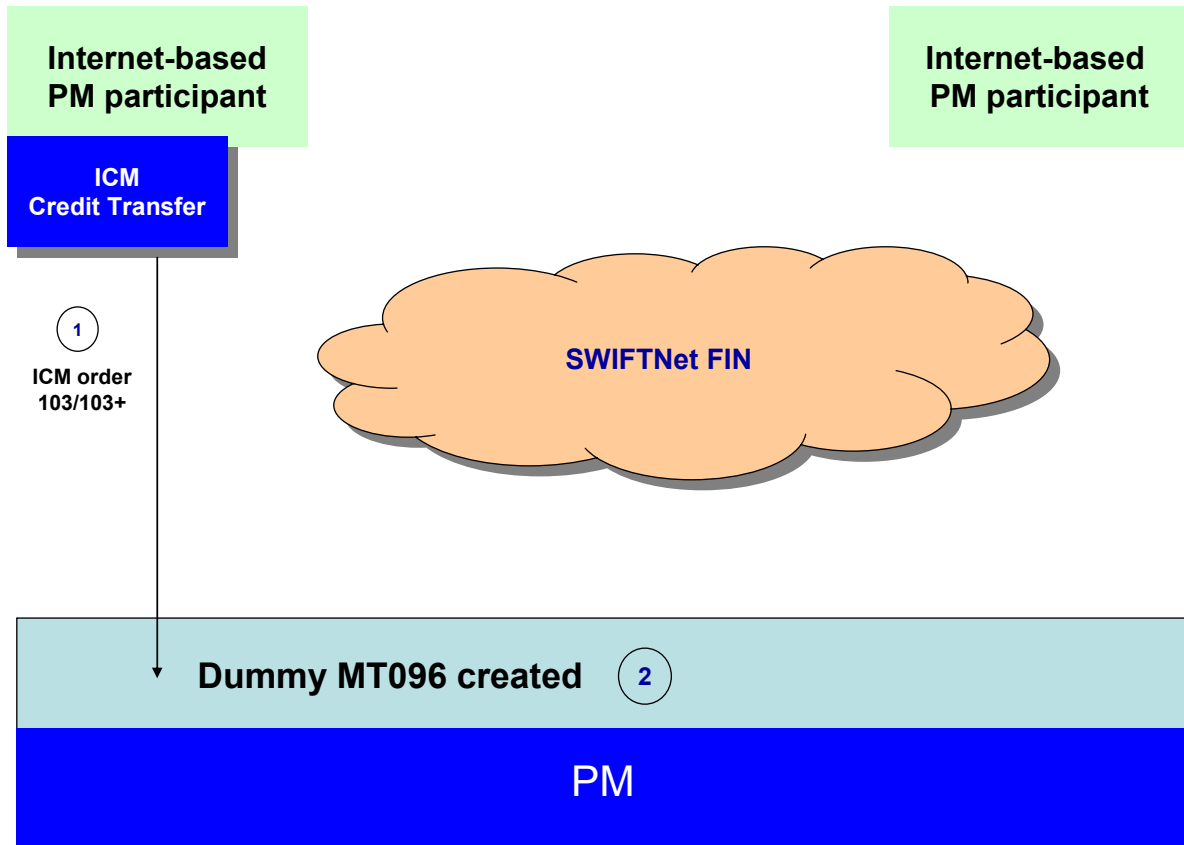

** Internal and MT096-MT097 messages are not explained*

Message	BIC of respective SSP-Module	Field entry
① ICM: Enter MT 103 from Internet Based participant PM	N/A	S: N/A R: TRGTXEPLVP 113: Banking Priority 20: TRN 21: Related Reference 32A: Value date, currency code and amount ... 57a: Internet Based Participant ...
② Dummy MT096		A dummy MT096 is created from ①. It is not sent to SWIFT.

2 Flow of payments/transactions

2.1 Credit transfer

2.1.1 Credit transfer to a direct participant

2.1.1.6 From CB customer to SWIFT-based participant.

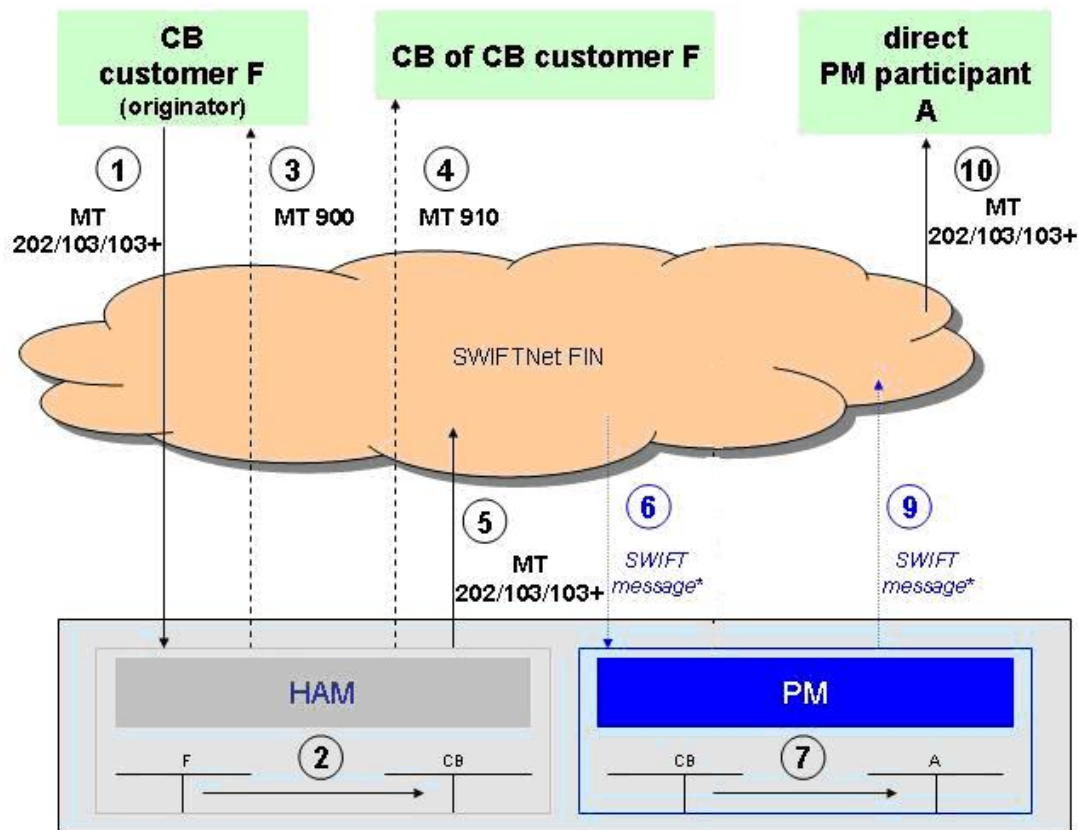

* Internal and SWIFT messages are not explained

Message	BIC of respective SSP-Module	Field entry
① MT 202 from CB customer F to HAM	TRGTXECBccX (CB Customer Liquidity Bridge)	S: CB customer F (HAM) R: TRGTXECBccX
		20: TRN 21: Related Reference 32A: Value date, currency code and amount ... 52: CB customer F (HAM) ... 58a: Direct PM participant A ...

2 Flow of payments/transactions

2.1 Credit transfer

2.1.1 Credit transfer to a direct participant

② Booking		HAM debits the account of CB customer F and credits the account (liquidity bridge) of the CB of CB customer F
③ MT 900 (optional) from HAM to CB customer F	TRGTXECBccX (CB Customer Liquidity Bridge)	<p>S: TRGTXECBccX R: CB customer F (HAM)</p> <p>20: TRN by SSP 21: Field 20 (TRN) of initial MT 202/103/103+ ① 25: Account of CB customer F (HAM) debited) 32A: Value date, currency code and amount ... 52a: CB customer F (HAM) ...</p>
④ MT 910 (optional) from HAM to CB of CB customer F	TRGTXECBccX (CB Customer Liquidity Bridge)	<p>S: TRGTXECBccX R: CB of CB Customer F</p> <p>20: TRN by SSP 21: Field 20 (TRN) of initial MT 202/103/103+ ① 25: Account of CB of CB customer F (credited) 32A: Value date, currency code and amount ... 52a: CB customer F (HAM) 72: /SETTIME/HHMMSSCC /INTERMOD/</p>
⑤ MT 202 from HAM to direct PM participant A	TRGTXECBccX (CB Customer Liquidity Bridge)	<p>S: TRGTXECBccX R: Direct PM participant A 103: TGT (service identifier)</p> <p>20: TRN 21: Related Reference 32A: Value date, currency code and amount ... 52a: //HAM<BIC of CB customer F (HAM)><TRN>BIC of CB customer F (HAM) ... 58a: Direct PM participant A ...</p>

2 Flow of payments/transactions

2.1 Credit transfer

2.1.1 Credit transfer to a direct participant

⑦ Booking		PM debits the account (liquidity bridge) of CB of CB customer F and credits the RTGS account of the direct PM participant A
⑩ MT 202 to direct PM participant A	TRGTXECBccX (CB Customer Liquidity Bridge)	Message from ⑤

2 Flow of payments/transactions

2.1 Credit transfer

2.1.1 Credit transfer to a direct participant

2.1.1.7 From SWIFT-based CB customers to Internet-based direct PM participant.

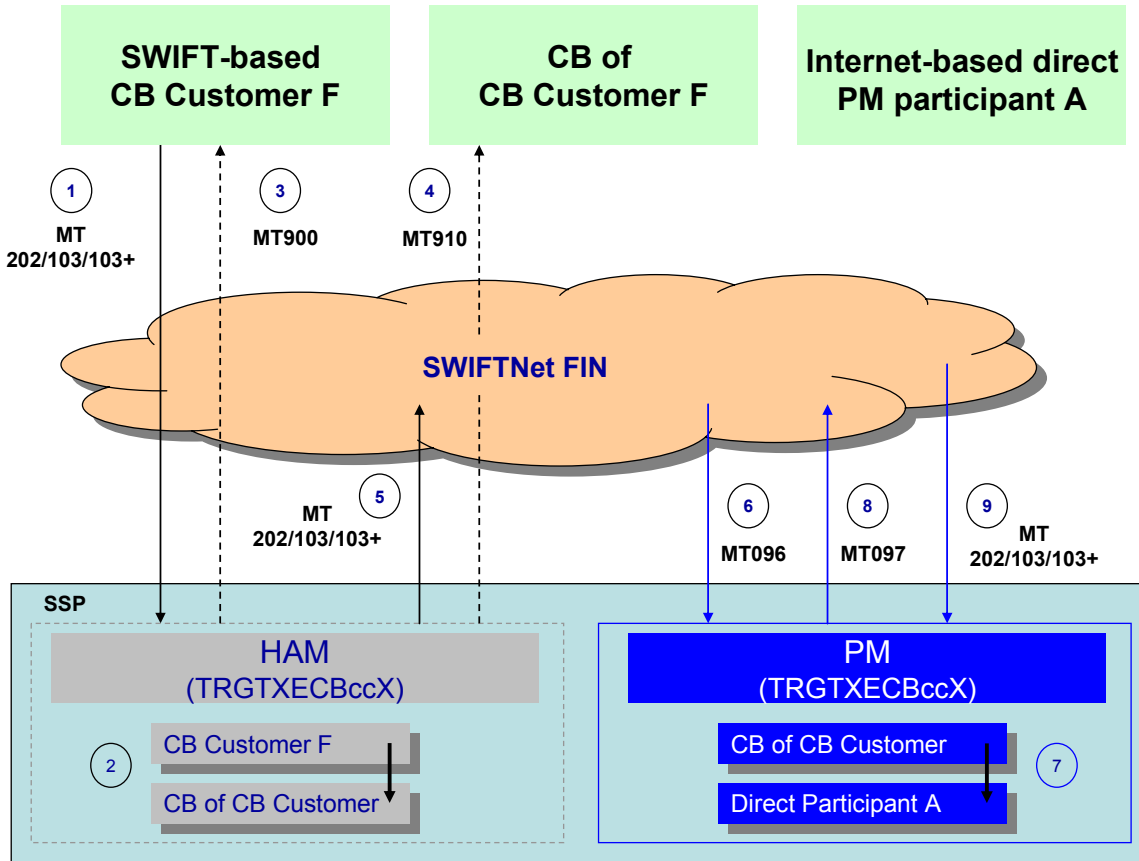

* Internal and MT096/MT097 messages are not explained

Message	BIC of respective SSP-Module	Field entry
① MT 202 from CB customer F to HAM	TRGTXEBCcX (CB Customer Liquidity Bridge)	S: CB customer F (HAM) R: TRGTXEBCcX
		20: TRN 21: Related Reference 32A: Value date, currency code and amount ... 52: CB customer F (HAM) ... 58a: Internet-based Direct PM participant A ...

2 Flow of payments/transactions

2.1 Credit transfer

2.1.1 Credit transfer to a direct participant

② Booking		HAM debits the account of CB customer F and credits the account (liquidity bridge) of the CB of CB customer F
③ MT 900 (optional) from HAM to CB customer F	TRGTXECBccX (CB Customer Liquidity Bridge)	<p>S: TRGTXECBccX R: CB customer F (HAM)</p> <p>20: TRN by SSP 21: Field 20 (TRN) of initial MT 202/103/103+ ① 25: Account of CB customer F (HAM) debited 32A: Value date, currency code and amount ... 52a: CB customer F (HAM)</p>
④ MT 910 (optional) from HAM to CB of CB customer F	TRGTXECBccX (CB Customer Liquidity Bridge)	<p>S: TRGTXECBccX R: CB of CB Customer F</p> <p>20: TRN by SSP 21: Field 20 (TRN) of initial MT 202/103/103+ ① 25: Account of CB of CB customer F (credited) 32A: Value date, currency code and amount ... 52a: CB customer F (HAM) 72: /SETTIME/HHMMSSCC /INTERMOD/</p>
⑤ MT 202 from HAM to SWIFT	TRGTXECBccX (CB Customer Liquidity Bridge)	<p>S: TRGTXECBccX R: TRGTXEPMLVP 103: TGT (service identifier)</p> <p>20: TRN 21: Related Reference 32A: Value date, currency code and amount ... 52a: //HAM<BIC of CB customer F (HAM)><TRN>BIC of CB customer F (HAM) ... 58a: Direct PM participant A ...</p>

2 Flow of payments/transactions

2.1 Credit transfer

2.1.1 Credit transfer to a direct participant

⑦ Booking		PM debits the account (liquidity bridge) of CB of CB customer F and credits the RTGS account of the direct PM participant A
⑨ MT 202 from SWIFT to PM	TRGTXECBccX (CB Customer Liquidity Bridge)	Message from ⑤ internally assigned to PM (not delivered to Internet-based participant)

2 Flow of payments/transactions

2.1 Credit transfer

2.1.1 Credit transfer to a direct participant

2.1.1.8 From Internet-based CB customers to SWIFT-based participant

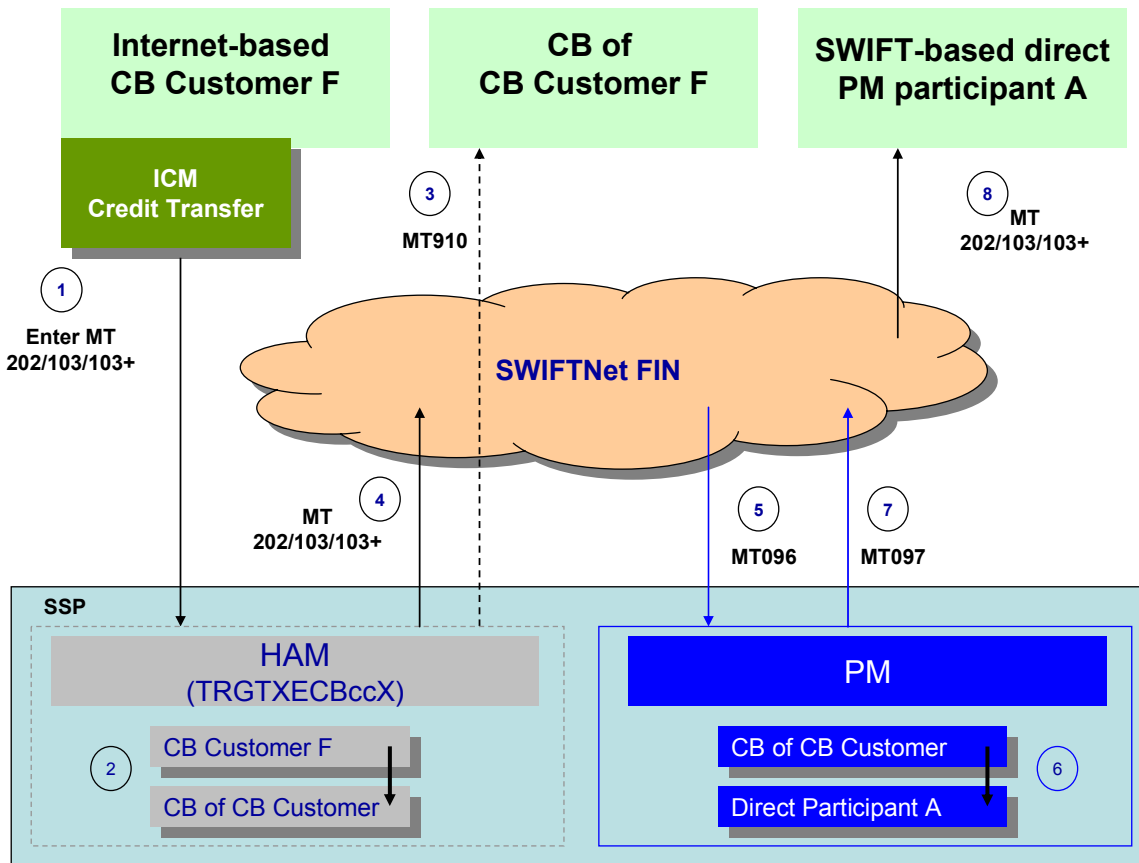

* Internal and MT096/MT097 messages are not explained

Message	BIC of respective SSP-Module	Field entry
① ICM Credit Transfer MT202 from CB customer F	N/A	S: N/A R: TRGTXECBccX 113 Priority 20: TRN 21: Related Reference 32A: Value date, currency code and amount ... 52A: CB customer F (HAM) ... 58a: Direct PM SWIFT-based participant A ...

2 Flow of payments/transactions

2.1 Credit transfer

2.1.1 Credit transfer to a direct participant

② Booking		HAM debits the account of CB customer F and credits the account (liquidity bridge) of the CB of CB customer F
③ MT 910 (optional) from HAM to CB of CB customer F	TRGTXECBccX (CB Customer Liquidity Bridge)	<p>S: TRGTXECBccX R: CB of CB Customer F</p> <p>20: TRN by SSP 21: Field 20 (TRN) of initial MT 202/103/103+ ① 25: Account of CB of CB customer F (credited) 32A: Value date, currency code and amount</p> <p>52a: CB customer F (HAM) 72: /SETTIME/HHMMSSCC /INTERMOD/</p>
④ MT 202 from HAM to direct PM participant A	TRGTXECBccX (CB Customer Liquidity Bridge)	<p>S: TRGTXECBccX R: Direct PM participant A 103: TGT (service identifier)</p> <p>20: TRN 21: Related Reference 32A: Value date, currency code and amount ... 52a: //HAM<BIC of CB customer F (HAM)><TRN>BIC of CB customer F (HAM) ... 58a: Direct PM participant A ...</p>
⑥ Booking		PM debits the account (liquidity bridge) of CB of CB customer F and credits the RTGS account of the direct PM participant A
⑧ MT 202 to direct PM participant A	TRGTXECBccX (CB Customer Liquidity Bridge)	Message from ④

2 Flow of payments/transactions

2.1 Credit transfer

2.1.1 Credit transfer to a direct participant

2.1.1.9 From Internet-based CB customers to Internet-based participant.

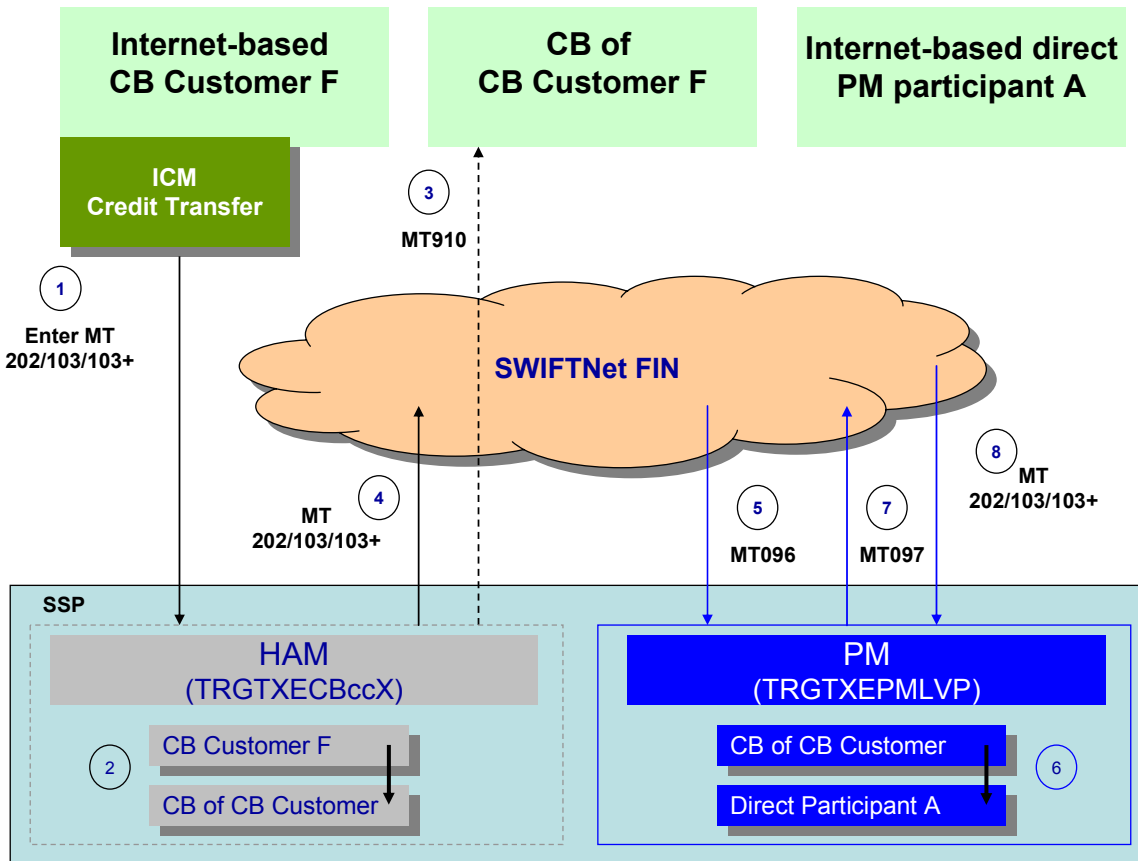

* Internal and MT096/MT097 messages are not explained

Message	BIC of respective SSP-Module	Field entry
① ICM Credit Transfer MT202 from CB customer F	N/A	S: N/A R: TRGTXECBccX 113 Priority 20: TRN 21: Related Reference 32A: Value date, currency code and amount ... 52A: CB customer F (HAM) ... 58a: Direct PM Internet-based participant A ...

2 Flow of payments/transactions

2.1 Credit transfer

2.1.1 Credit transfer to a direct participant

② Booking		HAM debits the account of CB customer F and credits the account (liquidity bridge) of the CB of CB customer F
③ MT 910 (optional) from HAM to CB of CB customer F	TRGTXECBccX (CB Customer Liquidity Bridge)	<p>S: TRGTXECBccX R: CB of CB Customer F</p> <p>20: TRN by SSP 21: Field 20 (TRN) of initial MT 202/103/103+ ① 25: Account of CB of CB customer F (credited) 32A: Value date, currency code and amount</p> <p>52a: CB customer F (HAM) 72: /SETTIME/HHMMSSCC /INTERMOD/</p>
④ MT 202 from HAM to SWIFT	TRGTXECBccX (CB Customer Liquidity Bridge)	<p>S: TRGTXECBccX R: TRGTXEPMLVP 103 TGT (service identifier)</p> <p>20: TRN from ① 21: Related Reference ① 32A: Value date, currency code and amount ... 52a: //HAM<BIC of CB customer F (HAM)><TRN> BIC of CB customer F (HAM) ... 58a: Direct PM Internet-based participant A ...</p>
⑥ Booking		PM debits the account (liquidity bridge) of CB of CB customer F and credits the RTGS account of the direct PM participant A
⑧ MT 202 from SWIFT to PM	TRGTXECBccX (CB Customer Liquidity Bridge)	Message from ⑤ internally assigned to PM (not delivered to Internet-based participant)

2 Flow of payments/transactions

2.1 Credit transfer

2.1.2 Credit transfer to an indirect participant

2.1.2 Credit transfer to an indirect participant

2.1.2.1 From CI as direct participant

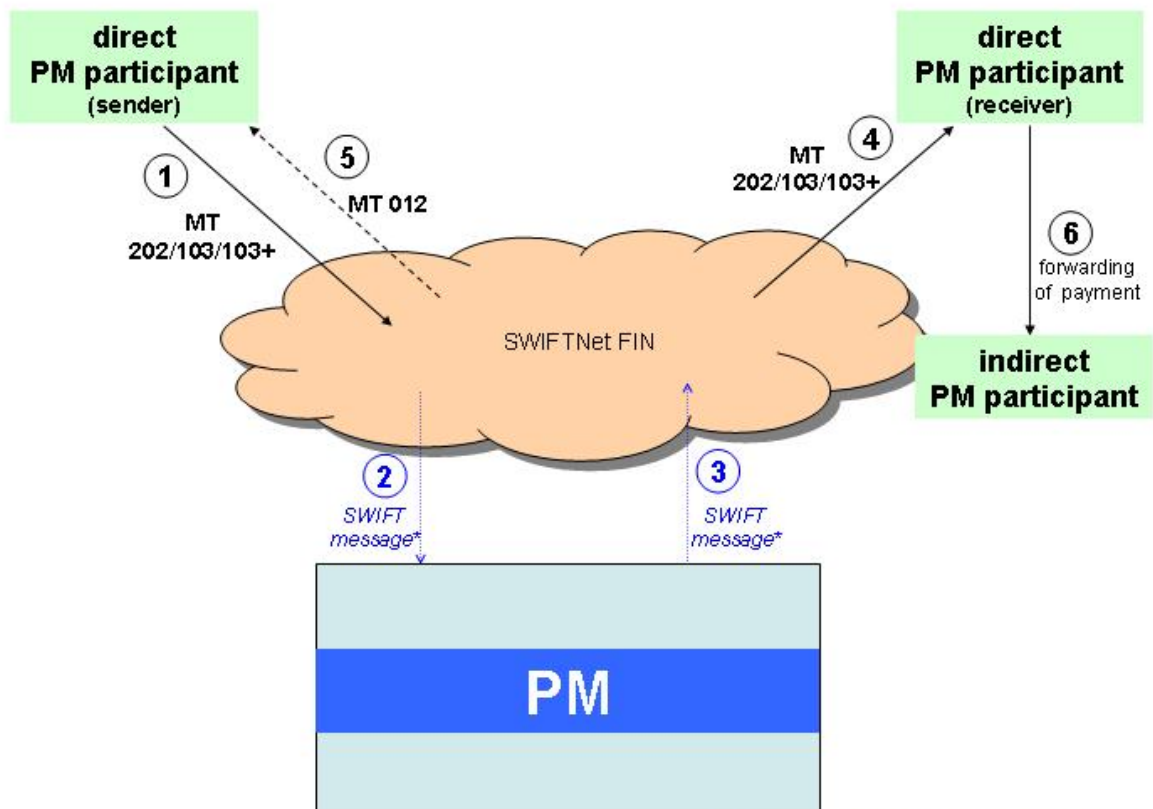

* Internal and SWIFT messages are not explained

Message	BIC of respective SSP-Module	Field entry
① MT 202 from direct PM		S: Direct PM participant (sender) R: Direct PM participant (receiver) 103: TGT (service identifier)

2 Flow of payments/transactions

2.1 Credit transfer

2.1.2 Credit transfer to an indirect participant

Message	BIC of respective SSP-Module	Field entry
participant		20: TRN 21: Related Reference 32A: Value date, currency code and amount ... 58a: Indirect PM participant ...
④ MT 202 to direct PM participant		Message from ①
⑤ MT 012 (optional) from SWIFT to sender		S: SWIFT system R: Direct PM participant (sender)
		175: Input time of the initial MT 202/103/103+ ① 106: Message Input Reference (MIR) of the initial MT 202/103/103+ ① 108: Message User Reference (MUR) if filled, else: TRN of initial MT 202/103/103+ ① 102: SWIFT address of receiver (complete 12 character destination) 103: TGT (service identifier) 114: Payment-release-information-sender (credit and debit time, country code of sender and reference of the initial MT 202/103/103+ (field 20) ①)
⑥ Forwarding of payment		- outside the scope of SSP -

2 Flow of payments/transactions

2.1 Credit transfer

2.1.2 Credit transfer to an indirect participant

2.1.2.2 From CI as indirect participant

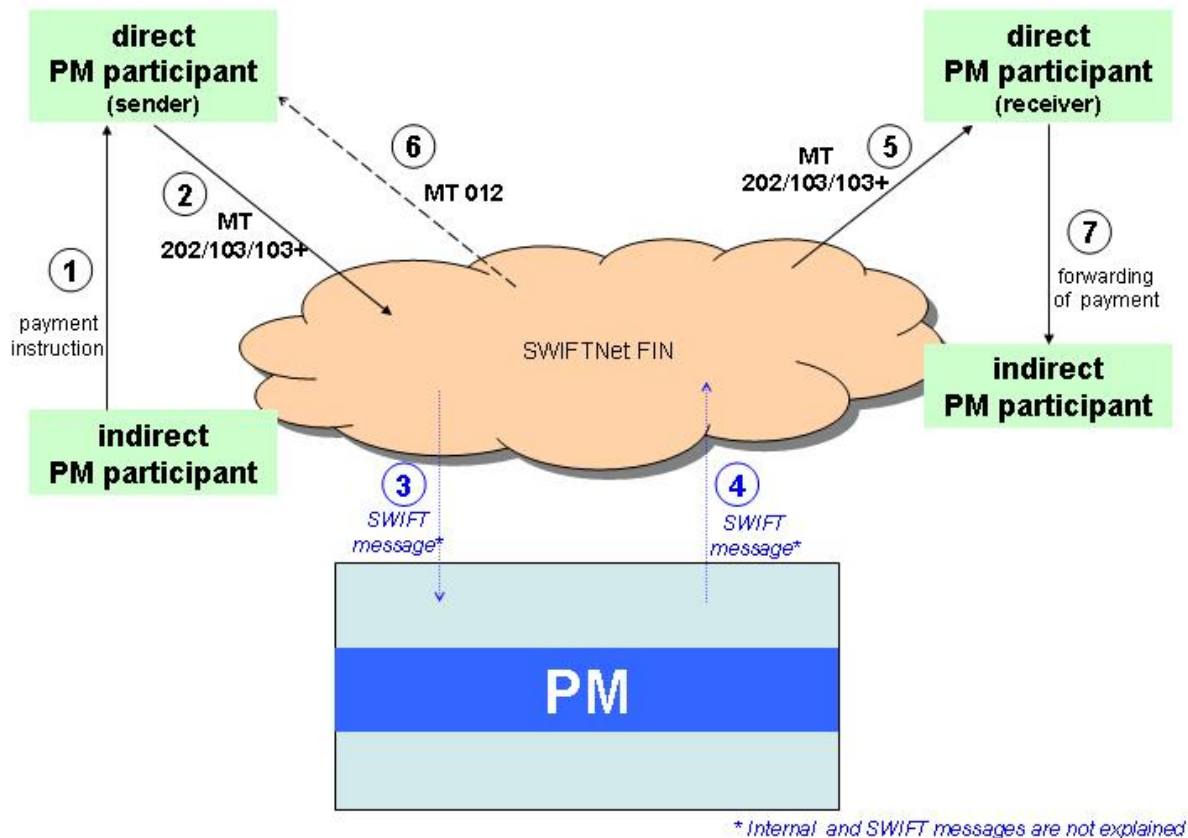

Message	BIC of respective SSP-Module	Field entry
① payment instruction		- outside the scope of SSP -
② MT 202 from direct PM		S: Direct PM participant (sender) R: Direct PM participant (receiver) 103: TGT (service identifier)

2 Flow of payments/transactions

2.1 Credit transfer

2.1.2 Credit transfer to an indirect participant

Message	BIC of respective SSP-Module	Field entry
participant (sender)		20: TRN 21: Related Reference 32A: Value date, currency code and amount ... 52a: Indirect PM participant (instructed initial MT 202/103/103+ ①) ... 58a: Indirect PM participant (receiver) ...
⑤ MT 202 to direct PM participant		Message from ②
⑥ MT 012 (optional) from SWIFT to sender		S: SWIFT system R: Direct PM participant (sender) 175: Input time of the initial MT 202/103/103+ ② 106: Message Input Reference (MIR) of initial MT 202/103/103+ ② 108: Message User Reference (MUR) if filled, else: TRN of initial MT 202/103/103+ ② 102: SWIFT address of receiver (complete 12 character destination) 103: TGT (service identifier) 114: Payment-release-information-sender (credit and debit time, country code of sender and reference of the initial MT 202/103/103+ (field 20) ②)
⑦ Forwarding of payment		- outside the scope of SSP -

2 Flow of payments/transactions

2.1 Credit transfer

2.1.2 Credit transfer to an indirect participant

2.1.2.3 From SWIFT-based CB customers

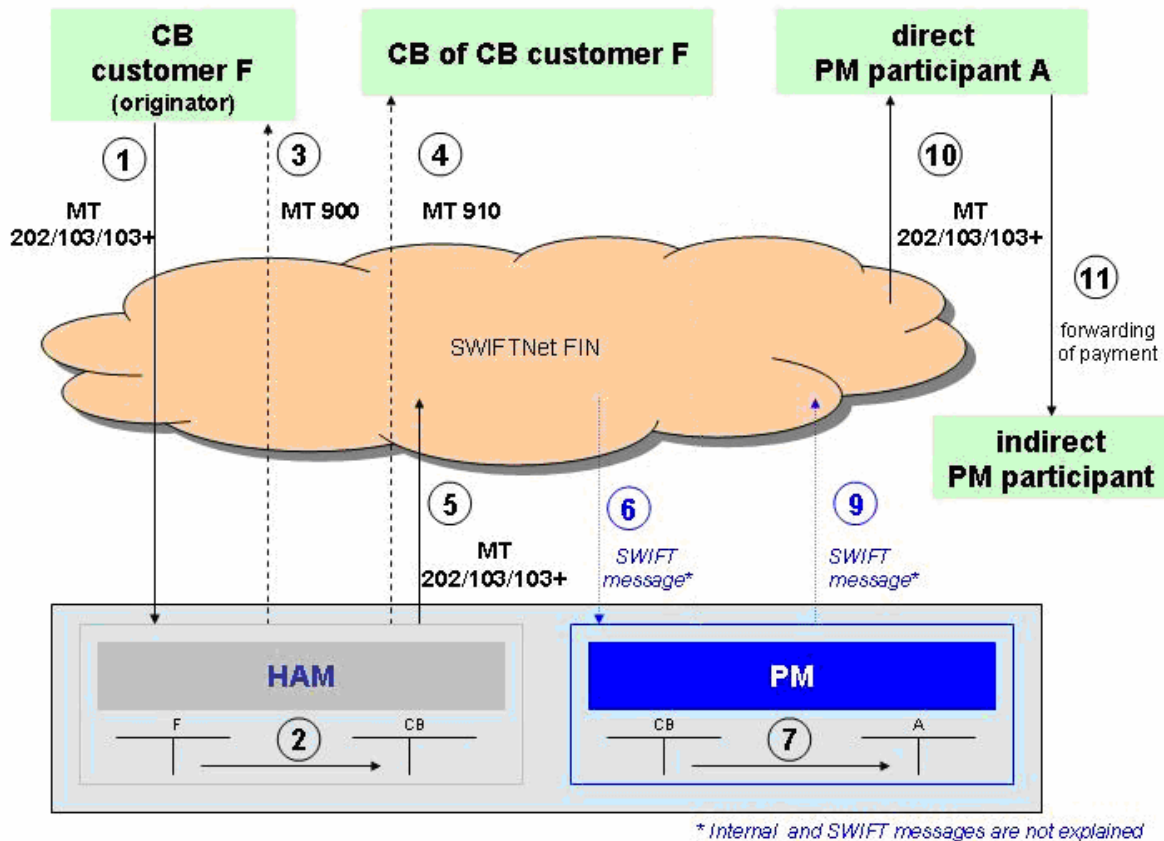

Message	BIC of respective SSP-Module	Field entry
① MT 202 from CB customer F to HAM	TRGTXECBccX (CB Customer Liquidity Bridge)	S: CB customer F (HAM) R: TRGTXECBccX
		20: TRN 21: Related Reference 32A: Value date, currency code and amount ... 58a: Indirect PM participant ...

2 Flow of payments/transactions

2.1 Credit transfer

2.1.2 Credit transfer to an indirect participant

② Booking		HAM debits the account of CB customer F and credits the account (liquidity bridge) of the CB of CB customer F
③ MT 900 (optional) from HAM to CB customer F	TRGTXECBccX (CB Customer Liquidity Bridge)	S: TRGTXECBccX R: CB customer F (HAM)
		20: TRN by SSP 21: Field 20 (TRN) of initial MT 202/103/103+ ① 25: Account of CB customer F ((HAM) debited) 32A: Value date, currency code and amount ... 52a: CB customer F (HAM) ...
④ MT 910 (optional) from HAM to CB of CB customer F	TRGTXECBccX (CB Customer Liquidity Bridge)	S: TRGTXECBccX R: CB of CB Customer F
		20: TRN by SSP 21: Field 20 (TRN) of initial MT 202/103/103+ ① 25: Account of CB of CB customer F (credited) 32A: Value date, currency code and amount 52a: CB customer F (HAM) 72: /SETTIME/HHMMSSCC /INTERMOD/
⑤ MT 202 from HAM to direct PM participant A	TRGTXECBccX (CB Customer Liquidity Bridge)	S: TRGTXECBccX R: Direct PM participant A 103: TGT (service identifier)
		20: TRN 21: Related Reference 32A: Value date, currency code and amount ... 52a: //HAM+BIC of CB customer F (HAM)<TRN> BIC of CB customer F (HAM) ... 58a: Indirect PM participant ...
⑦ Booking		PM debits the account (liquidity bridge) of CB of CB customer F and credits the RTGS account of the direct PM participant A
⑩ MT 202 to direct PM participant A	TRGTXECBccX (CB Customer Liquidity Bridge)	Message from ⑤
⑪ Forwarding of payment		- outside the scope of SSP -

2 Flow of payments/transactions

2.1 Credit transfer

2.1.2 Credit transfer to an indirect participant

2.1.2.4 From Internet-based CB customers

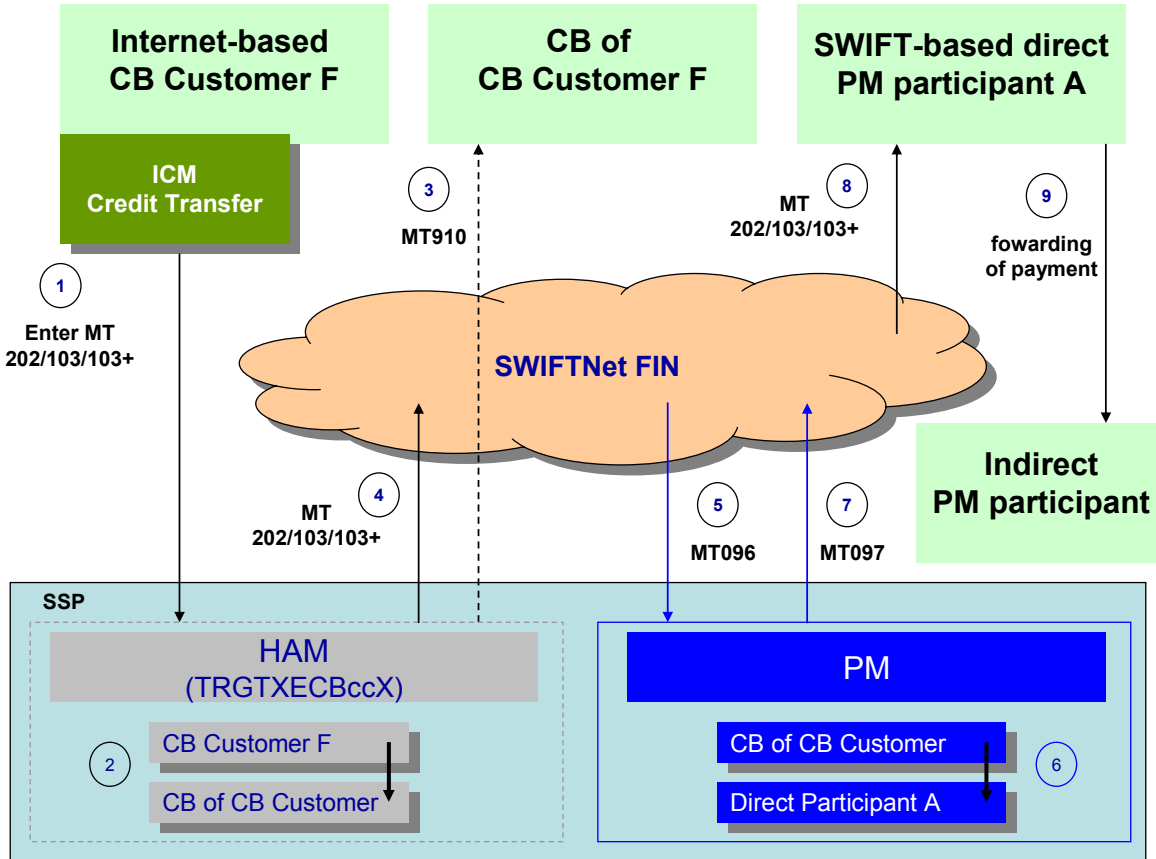

* Internal and MT096/MT097 messages are not explained

Message	BIC of respective SSP-Module	Field entry
① ICM: Credit Transfer: Enter MT202 from CB customer F to HAM	N/A	S: N/A R: TRGTXECBccX 113 Bank Priority 20: TRN 21: Related Reference 32A: Value date, currency code and amount 52A... CB customer F (HAM) 58a: Indirect PM participant ...

2 Flow of payments/transactions

2.1 Credit transfer

2.1.2 Credit transfer to an indirect participant

② Booking		HAM debits the account of CB customer F and credits the account (liquidity bridge) of the CB of CB customer F
③ MT 910 (optional) from HAM to CB of CB customer F	TRGTXECBccX (CB Customer Liquidity Bridge)	S: TRGTXECBccX R: CB of CB Customer F
		20: TRN by SSP 21: Field 20 (TRN) of initial MT 202/103/103+ ① 25: Account of CB of CB customer F (credited) 32A: Value date, currency code and amount 52a: CB customer F (HAM) 72: /SETTIME/HHMMSSCC /INTERMOD/
④ MT 202 from HAM to direct PM participant A	TRGTXECBccX (CB Customer Liquidity Bridge)	S: TRGTXECBccX R: Direct PM participant A 103: TGT (service identifier)
		20: TRN 21: Related Reference 32A: Value date, currency code and amount ... 52a: //HAM+BIC of CB customer F (HAM)<TRN> BIC of CB customer F (HAM) ... 58a: Indirect PM participant ...
⑥ Booking		PM debits the account (liquidity bridge) of CB of CB customer F and credits the RTGS account of the direct PM participant A
⑧ MT 202 to direct PM participant A	TRGTXECBccX (CB Customer Liquidity Bridge)	Message from ⑤
⑨ Forwarding of payment		- outside the scope of SSP -

2 Flow of payments/transactions

2.1 Credit transfer

2.1.3 Credit transfer to a HAM participant

2.1.3 Credit transfer to a HAM participant

2.1.3.1 From CI as direct participant

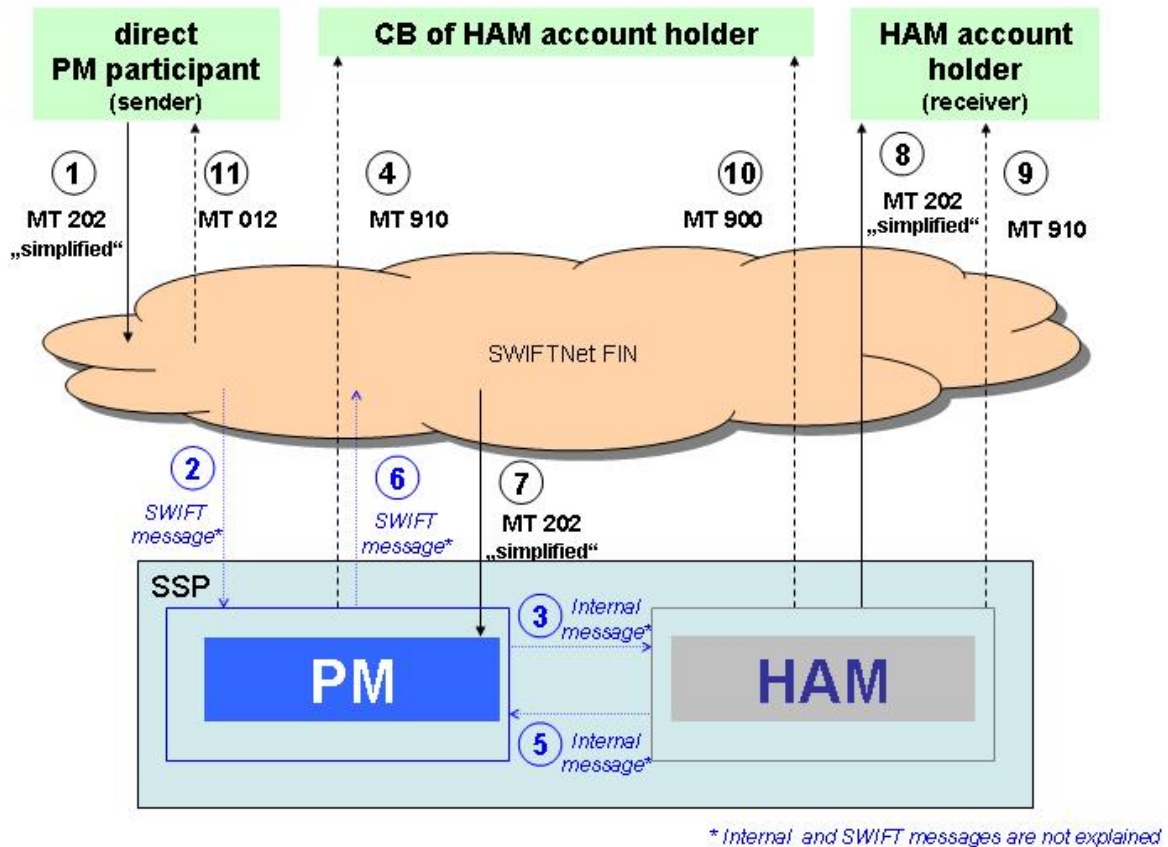

Message	BIC of respective SSP-Module	Field entry
① MT 202 "simplified" from direct PM participant to HAM	TRGTXEPMHAM (SSP-BIC of HAM)	S: Direct PM participant (sender) R: TRGTXEPMHAM 103: TGT (service identifier)
		20: TRN 21: Related Reference 32A: Value date, currency code and amount ... 58a: HAM account holder (receiver)

2 Flow of payments/transactions

2.1 Credit transfer

2.1.3 Credit transfer to a HAM participant

Message	BIC of respective SSP-Module	Field entry
④ MT 910 (optional) from PM to CB of HAM account holder	TRGTXEPMXXX (SSP-BIC of PM)	S: TRGTXEPMXXX R: CB of HAM account holder
		20: TRN by SSP 21: Field 20 (TRN) of initial MT 202 "simplified" ① 25: Account of CB of HAM account holder (credited) 32A: Value date, currency code and amount ... 52a: Direct PM participant (sender) ...
⑦ MT 202 "simplified" from direct PM participant to HAM	TRGTXEPHAM (SSP-BIC of HAM)	Original message from ① (Y-Copy)
⑧ MT 202 "simplified" from HAM to HAM account holder (receiver)	TRGTXEHMXXX (SSP-BIC of HAM)	S: TRGTXEHMXXX R: HAM account holder (receiver)
		20: TRN 21: Related Reference 32A: Value date, currency code and amount ... 52a: //HAM+BIC of direct PM participant (sender)<TRN (field 20) of initial MT 202 "simplified" ①>BIC of direct PM participant (sender) ... 58a: HAM account holder (receiver) ...
⑨ MT 910 (optional) from HAM to HAM account holder (receiver)	TRGTXEHMXXX (SSP-BIC of HAM)	S: TRGTXEHMXXX R: HAM account holder (receiver)
		20: TRN by SSP 21: Field 20 (TRN) of initial MT 202 "simplified" ① 25: Account of HAM account holder (receiver) (credited) 32A: Value date, currency code and amount ... 52a: Direct PM participant (sender) ...
⑩ MT 900 (optional) from HAM to CB of HAM account holder	TRGTXEHMXXX (SSP-BIC of HAM)	S: TRGTXEHMXXX R: CB of HAM account holder

2 Flow of payments/transactions

2.1 Credit transfer

2.1.3 Credit transfer to a HAM participant

Message	BIC of respective SSP-Module	Field entry
		20: TRN by SSP 21: Field 20 (TRN) of initial MT 202 "simplified" ① 25: Account of CB of HAM account holder (debited) 32A: Value date, currency code and amount 52a: Direct PM participant (sender) 72: /SETTIME/HHMMSSCC /INTERMOD/
⑪ MT 012 (optional) from SWIFT to sender		S: SWIFT system R: Direct PM participant (sender) 175: Input time of the initial MT 202 "simplified" ① 106: Message Input Reference (MIR) of the initial MT 202 "simplified" ① 108: Message User Reference (MUR) if filled, else: TRN of initial MT 202 "simplified" ① 102: SWIFT address of receiver (complete 12 character destination) 103: TGT (service identifier) 114: Payment-release-information-sender (credit and debit time, country code of sender and reference of the initial MT 202 "simplified" (field 20) ①)

2 Flow of payments/transactions

2.1 Credit transfer

2.1.3 Credit transfer to a HAM participant

2.1.3.2 From CI as indirect participant

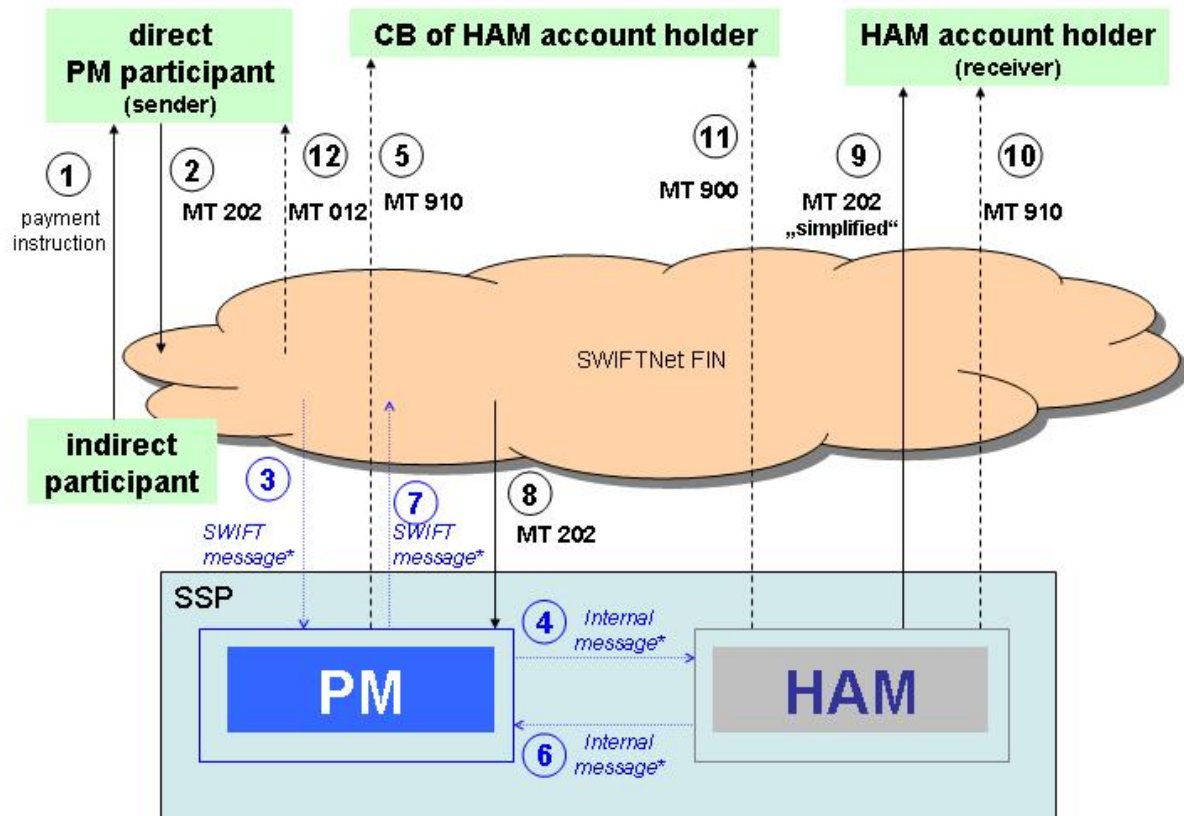

* Internal and SWIFT messages are not explained

Message	BIC of respective SSP-Module	Field entry
① Payment instruction		- outside the scope of SSP -
② MT 202 from direct PM participant to HAM	TRGTXEPMHAM (SSP-BIC of HAM)	S: Direct PM participant (sender) R: TRGTXEPMHAM 103: TGT (service identifier)

2 Flow of payments/transactions

2.1 Credit transfer

2.1.3 Credit transfer to a HAM participant

		20: TRN 21: Related Reference 32A: Value date, currency code and amount ... 52a: Indirect participant (instructed the MT 202 ②) ... 58a: HAM account holder (receiver) ...
⑤ MT 910 (optional) from PM to CB of HAM account holder	TRGTXEPMXXX (SSP-BIC of PM)	S: TRGTXEPMXXX R: CB of HAM account holder 20: TRN by SSP 21: Field 20 (TRN) of initial MT 202 “simplified” ② 25: Account of CB of HAM account holder (credited) 32A: Value date, currency code and amount ... 52a: Indirect PM participant (sender) ...
⑧ MT 202 from direct PM participant	TRGTXEPHAM (SSP-BIC of HAM)	Message from ②
⑨ MT 202 “simplified” from HAM to HAM account holder (receiver)	TRGTXEHMXXX (SSP-BIC of HAM)	S: TRGTXEHMXXX R: HAM account holder (receiver) 20: TRN by SSP 21: Related Reference 32A: Value date, currency code and amount ... 52a: //HAM+BIC of indirect participant <TRN (field 20) of initial MT 202 ②> BIC of indirect PM participant (sender) ... 58a: HAM account holder (receiver) ...
⑩ MT 910 (optional) from HAM to HAM account holder	TRGTXEHMXXX (SSP-BIC of HAM)	S: TRGTXEHMXXX R: HAM account holder (receiver)

2 Flow of payments/transactions

2.1 Credit transfer

2.1.3 Credit transfer to a HAM participant

		20: TRN by SSP 21: Field 20 (TRN) of initial MT 202 “simplified” ② 25: Account of HAM account holder (credited) 32A: Value date, currency code and amount ... 52a: Indirect PM participant (sender) ...
⑪ MT 900 (optional) from HAM to CB of HAM account holder	TRGTXEHMXXX (SSP-BIC of HAM)	S: TRGTXEHMXXX R: CB of HAM account holder
		20: TRN by SSP 21: Field 20 (TRN) of initial MT 202 “simplified” ② 25: Account of the CB of HAM account holder (debited) 32A: Value date, currency code and amount 52a: Indirect PM participant (sender) 72: /SETTIME/HHMMSSCC /INTERMOD/
⑫ MT 012 (optional) from SWIFT to sender		S: SWIFT System R: Direct PM participant (sender)
		175: Input time of the initial MT 202 “simplified” ② 106: Message Input Reference (MIR) of the initial MT 202 “simplified” ② 108: Message User Reference (MUR) if filled, else: TRN of initial MT 202 “simplified” ② 102: SWIFT address of receiver (complete 12 character destination) 103: TGT (service identifier) 114: Payment-release-information-sender (credit and debit time, country code of sender and reference of the initial MT 202 (field 20) ②)

2.1.3.3 From CB customers

Not allowed.

2 Flow of payments/transactions

2.1 Credit transfer

2.1.4 Credit transfer to a CB customer

2.1.4 Credit transfer to a CB customer

2.1.4.1 From SWIFT-based PM participant to SWIFT-based CB customer

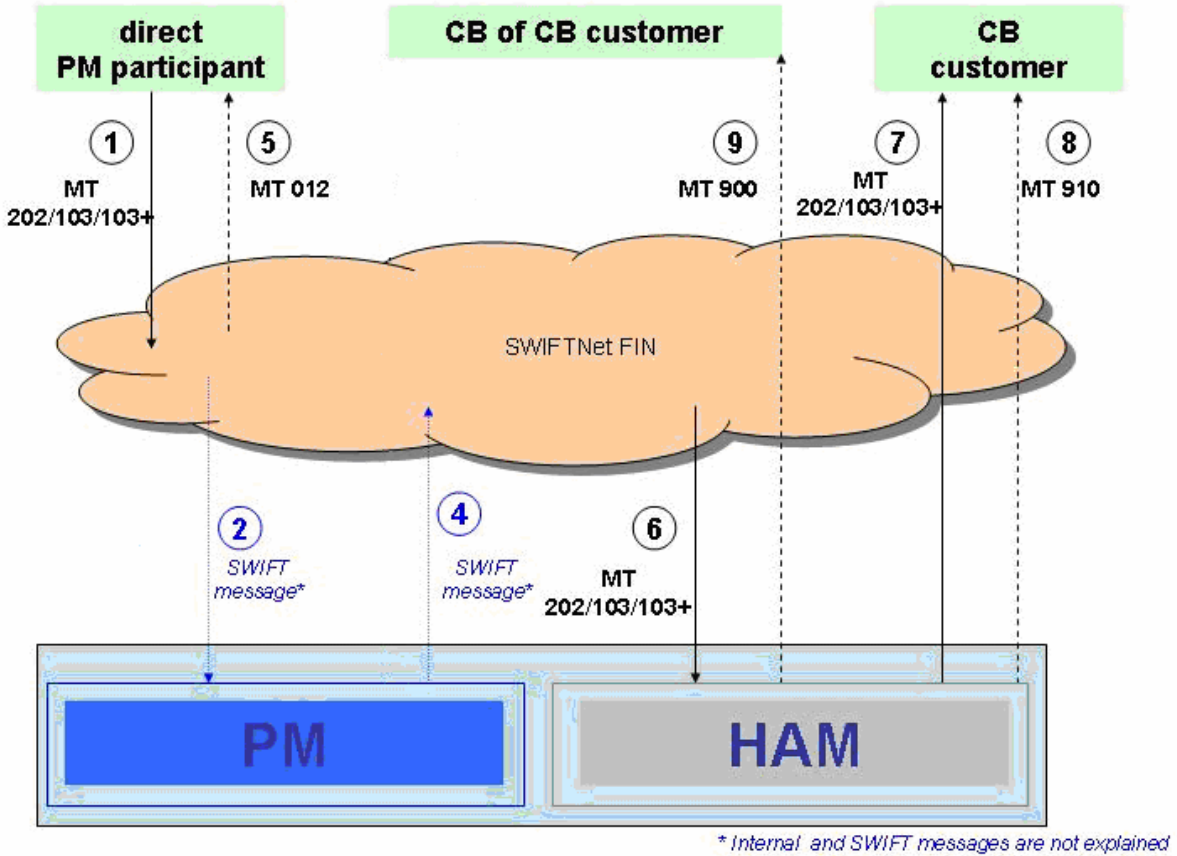

Message	BIC of respective SSP-Module	Field entry
① MT 202 from direct PM participant	TRGTXECBccX (CB Customer Liquidity Bridge)	S: Direct PM participant (sender) R: TRGTXECBccX 103: TGT (service identifier)

2 Flow of payments/transactions

2.1 Credit transfer

2.1.4 Credit transfer to a CB customer

		20: TRN 21: Related Reference 32A: Value date, currency code and amount ... 52a: Direct PM participant (sender) ... 58a: CB customer (receiver) ...
⑤ MT 012 (optional) from SWIFT to sender		S: SWIFT system R: Direct PM participant (sender)
		175: Input time of the initial MT 202/103/103+ ① 106: Message Input Reference (MIR) of the initial MT 202/103/103+ ① 108: Message User Reference (MUR) if filled, else: TRN of initial MT 202/103/103+ ① 102: SWIFT address of receiver (complete 12 character destination) 103: TGT (service identifier) 114: Payment-release-information-sender (credit and debit time, country code of sender and reference of the initial MT 202 (field 20) ①)
⑥ MT 202 from direct PM participant	TRGTXEBCcX (CB Customer Liquidity Bridge)	Message from ①
⑦ MT 202 from HAM to CB customer	TRGTXEBCcX (CB Customer Liquidity Bridge)	S: TRGTXEBCcX R: CB customer
		20: TRN 21: Related Reference 32A: Value date and amount ... 52a: //HAM+BIC of direct PM participant (sender) <TRN (field 20) of initial MT 202/103/103+ ①> BIC of direct PM participant (sender) ... 58a: CB customer (receiver) ...
⑧ MT 910 (optional) from HAM to	TRGTXEBCcX (CB Customer	S: TRGTXEBCcX R: CB customer (receiver)

2 Flow of payments/transactions

2.1 Credit transfer

2.1.4 Credit transfer to a CB customer

		20: TRN by SSP 21: Field 20 (TRN) of initial MT 202/103/103+ ① 25: Account of CB customer (credited) 32A: Value date, currency code and amount ... 52a: Direct PM participant (sender) ...
⑨ MT 900 (optional) from HAM to CB of CB customer	TRGTXECBccX (CB Customer Liquidity Bridge)	S: TRGTXECBccX R: CB of CB customer
		20: TRN by SSP 21: Field 20 (TRN) of initial MT 202/103/103+ ① 25: Account of CB of CB customer (debited) 32A: Value date, currency code and amount 52a: Direct PM participant (sender) 72: /SETTIME/HHMMSSCC /INTERMOD/

2 Flow of payments/transactions

2.1 Credit transfer

2.1.4 Credit transfer to a CB customer

2.1.4.2 From CI as indirect participant to SWIFT-based CB customer

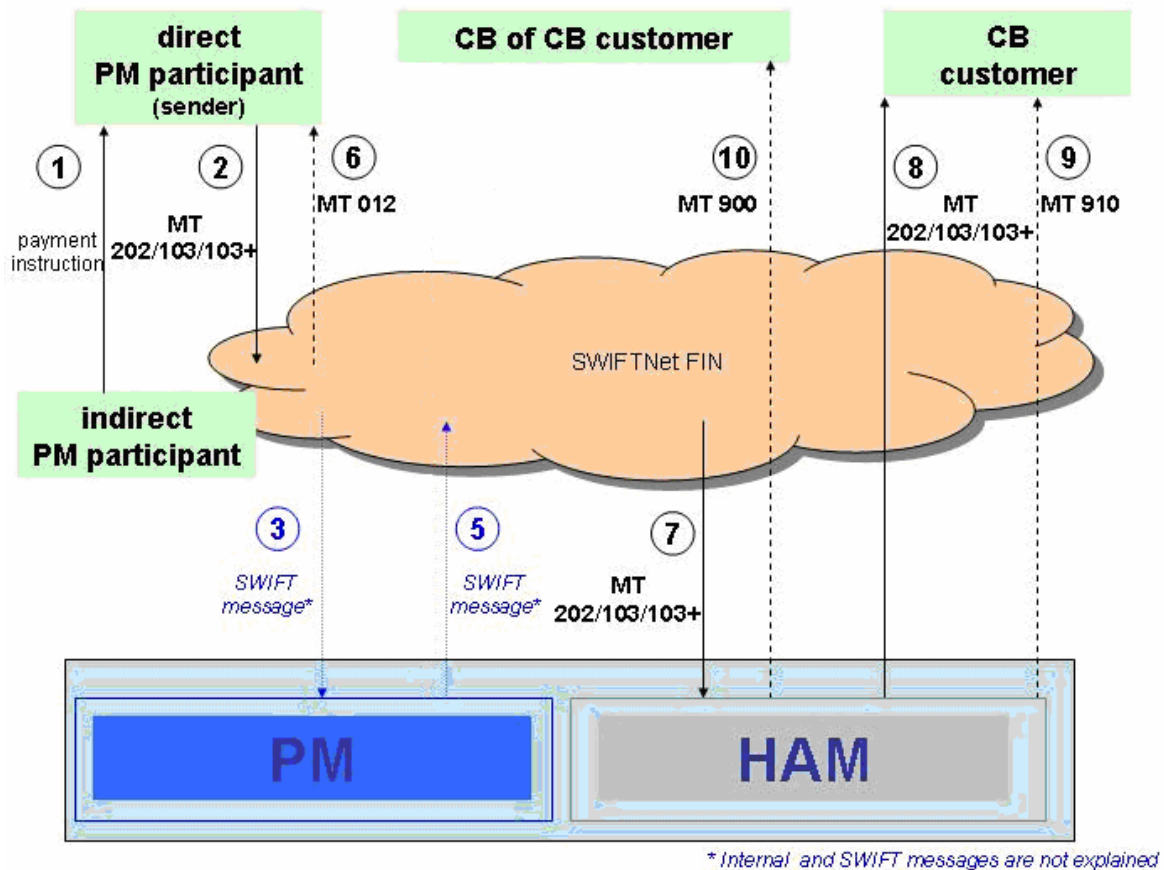

Message	BIC of respective SSP-Module	Field entry
① Payment instruction		- outside the scope of SSP -
② MT 202 from direct PM participant	TRGTXECBccX (CB Customer Liquidity Bridge)	S: Direct PM participant (sender) R: TRGTXECBccX 103: TGT (service identifier)

2 Flow of payments/transactions

2.1 Credit transfer

2.1.4 Credit transfer to a CB customer

		20: TRN 21: Related Reference 32A: Value date, currency code and amount ... 52a: Indirect PM participant (instructed initial MT 202/103/103+ ①) ... 58a: CB customer (receiver)
⑥ MT 012 (optional) from SWIFT to sender		S: SWIFT system R: Direct PM participant (sender) 175: Input time of the initial MT 202/103/103+ ② 106: Message Input Reference (MIR) of the initial MT 202/103/103+ ② 108: Message User Reference (MUR) if filled, else: TRN of initial MT 202/103/103+ ② 102: SWIFT address of receiver (complete 12 character destination) 103: TGT (service identifier) 114: Payment-release-information-sender (credit and debit time, country code of sender and reference of the initial MT 202 (field 20) ②)
⑦ MT 202 from direct PM participant	TRGTXECBccX (CB Customer Liquidity Bridge)	Message from ②
⑧ MT 202 from HAM to CB customer	TRGTXECBccX (CB Customer Liquidity Bridge)	S: TRGTXECBccX R: CB customer 20: TRN 21: Related Reference 32A: Value date, currency code and amount ... 52a: //HAM+TRGTXECBccX<TRN (field 20) of initial MT 202/103/103+ ② >BIC of indirect PM participant (sender) ... 58a: CB customer (receiver) ...
⑨ MT 910 (optional) from HAM to CB customer	TRGTXECBccX (CB Customer Liquidity Bridge)	S: TRGTXECBccX R: CB customer (receiver)

2 Flow of payments/transactions

2.1 Credit transfer

2.1.4 Credit transfer to a CB customer

		20: TRN by SSP 21: Field 20 (TRN) of initial MT 202/103/103+ ② 25: Account of CB customer (credited) 32A: Value date, currency code and amount ... 52a: Indirect PM participant ...
⑩ MT 900 (optional) from HAM to CB of CB customer	TRGTXECBccX (CB Customer Liquidity Bridge)	S: TRGTXECBccX R: CB of CB customer
		20: TRN by SSP 21: Field 20 (TRN) of initial MT 202/103/103+ ② 25: Account of CB of CB customer (debited) 32A: Value date, currency code and amount ... 52a: Indirect PM participant 72: /SETTIME/HHMMSSCC /INTERMOD/

2 Flow of payments/transactions

2.1 Credit transfer

2.1.4 Credit transfer to a CB customer

2.1.4.3 From Internet-based PM participant to Internet-based CB customer

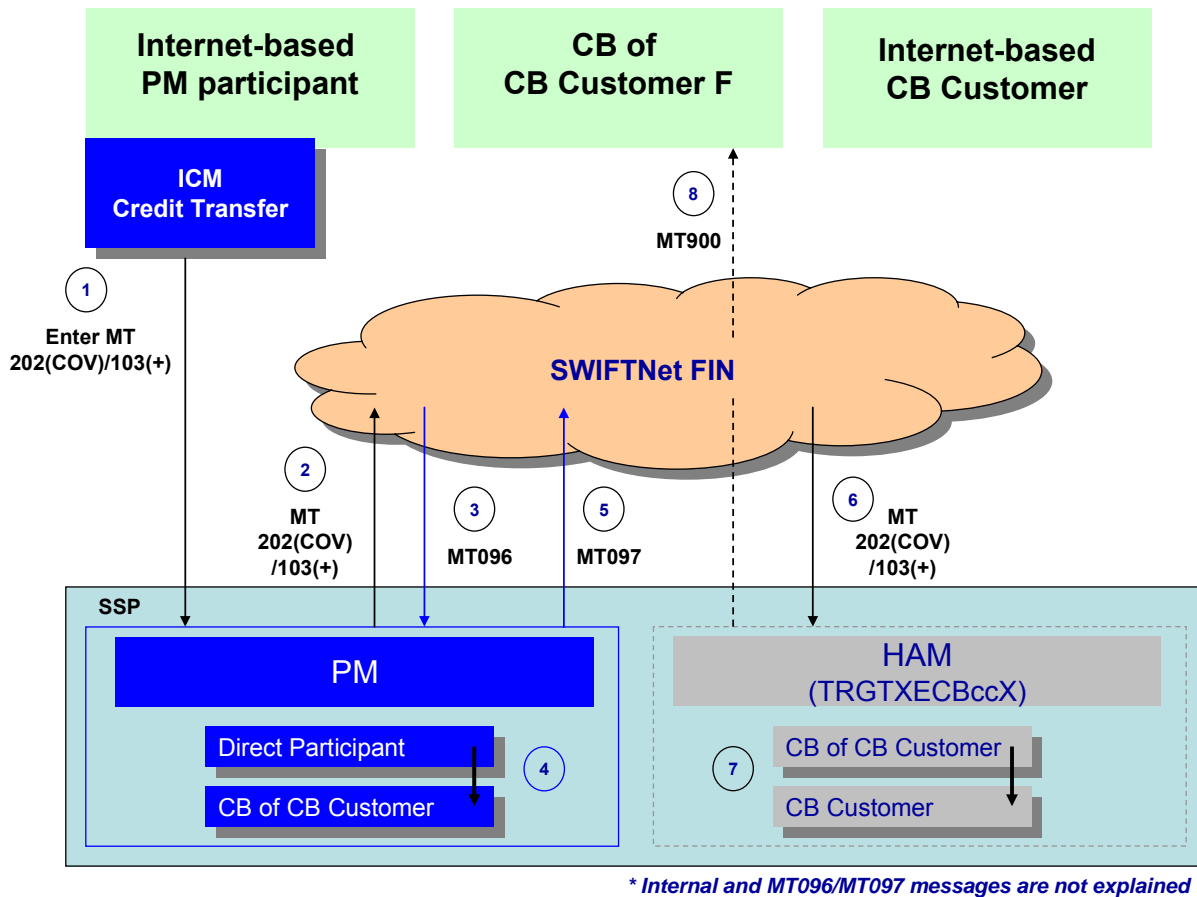

Message	BIC of respective SSP-Module	Field entry
① ICM: Credit Transfer: Enter MT202 from Internet-based PM participant	N/A	S: N/A R: TRGTXECBccX 113 Bank Priority
		20: TRN 21: Related Reference 32A: Value date, currency code and amount ... 52a: Internet-based PM participant ... 58a: Internet-based CB customer ...

2 Flow of payments/transactions

2.1 Credit transfer

2.1.4 Credit transfer to a CB customer

② MT 202 from PM to CB customer via PM	TRGTXECBccX (CB Customer Liquidity Bridge)	S: TRGTXECBLVP R: TRGTXECBccX 103: TGT (service identifier)
		20: TRN from initial credit transfer ① 21: REF from initial credit transfer ① 32A: Value date, currency code and amount ① ... 52a: Internet-based PM participant ① ... 58a: Internet-based CB customer (receiver) ① ...
④ Booking		PM debits the account of IB PM participant and credits the account (liquidity bridge) of the CB of CB customer
⑥ MT 202 from SWIFT to HAM	TRGTXECBccX (CB Customer Liquidity Bridge)	S: TRGTXECBLVP R: TRGTXECBccX
		Same message as ②
⑦ Booking		HAM debits the account (liquidity bridge) of the CB of CB customer and credits the account of the CB customer
⑧ MT 900 (optional) from HAM to CB of CB customer B	TRGTXECBccX (CB Customer Liquidity Bridge)	S: TRGTXECBccX R: CB of CB customer B
		20: TRN by SSP 21: NEW 25: Account of CB of CB customer (debited) 32A: Value date, currency code and amount ... 52a: TRGTXEPLVP 72: /SETTIME/HHMMSSCC /INTERMOD/

2 Flow of payments/transactions

2.1 Credit transfer

2.1.4 Credit transfer to a CB customer

2.1.4.3.1 2.1.4.3 From SWIFT-based PM participant to Internet-based CB customer

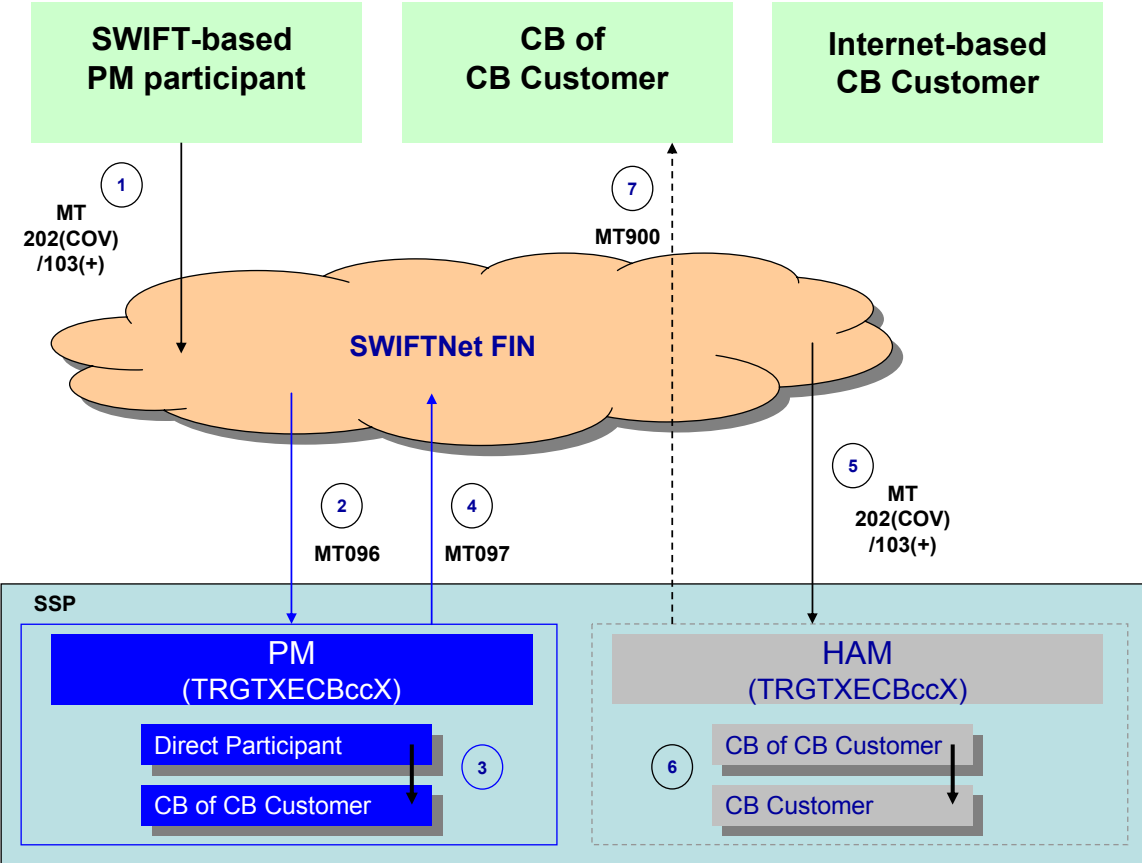

* Internal and MT096/MT097 messages are not explained

Message	BIC of respective SSP-Module	Field entry
① MT202 from SWIFT-based PM participant	TRGTXECBccX (CB Customer Liquidity Bridge)	S: SWIFT-based Participant BIC
		R: TRGTXECBccX
		103 TGT
		20: TRN
		21: Related Reference
		32A: Value date, currency code and amount
		...
		58a: Internet-based CB customer
		...

2 Flow of payments/transactions

2.1 Credit transfer

2.1.4 Credit transfer to a CB customer

③ Booking		PM debits the account of IB PM participant and credits the account (liquidity bridge) of the CB of CB customer
⑤ MT 202 from SWIFT to HAM	TRGTXECBccX (CB Customer Liquidity Bridge)	S: Participant BIC R: TRGTXECBccX
		Same message as ①
⑥ Booking		HAM debits the account (liquidity bridge) of the CB of CB customer and credits the account of the CB customer
⑦ MT 900 (<i>optional</i>) from HAM to CB of CB customer B	TRGTXECBccX (CB Customer Liquidity Bridge)	S: TRGTXECBxxX R: CB of CB customer B
		20: TRN by SSP 21: Reference (21) from ① 25: Account of CB of CB customer (debited) 32A: Value date, currency code and amount ... 52a: SWIFT-based PM participant BIC 72: /SETTIME/HHMMSSCC /INTERMOD/

2 Flow of payments/transactions

2.1 Credit transfer

2.1.4 Credit transfer to a CB customer

2.1.4.4 From Internet-based PM participant to SWIFT-based CB customer

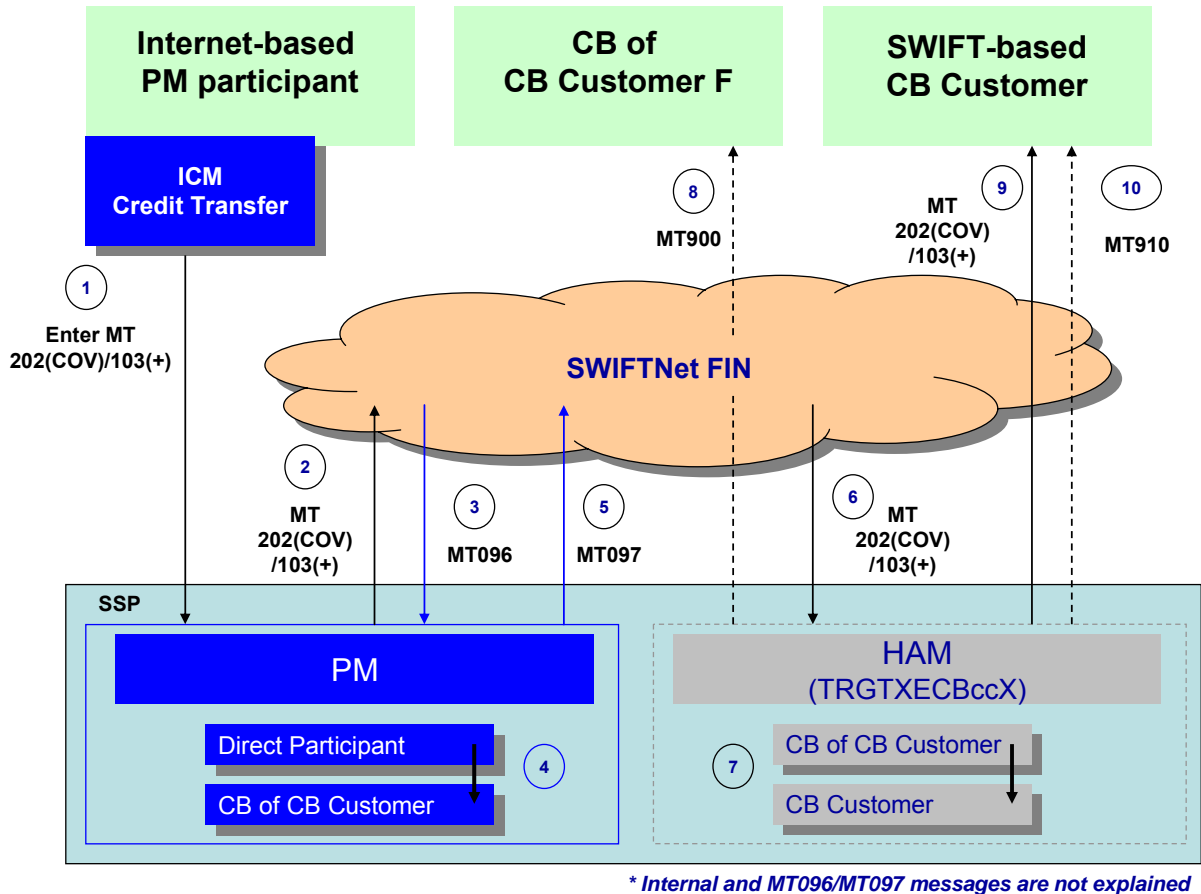

Message	BIC of respective SSP-Module	Field entry
① ICM: Credit Transfer: Enter MT202 from Internet-based PM	N/A	S: N/A R: TRGTXECBccX 113 Bank Priority

2 Flow of payments/transactions

2.1 Credit transfer

2.1.4 Credit transfer to a CB customer

		20: TRN 21: Related Reference 32A: Value date, currency code and amount ... 52a: Internet-based PM participant ... 58a: SWIFT-based CB customer ...
② MT 202 from PM to CB customer	TRGTXECBccX (CB Customer Liquidity Bridge)	S: TRGTXECBLVP R: TRGTXECBccX 103: TGT (service identifier)
		20: TRN from initial credit transfer ① 21: REF from initial credit transfer ① 32A: Value date, currency code and amount ① ... 52a: Internet-based PM participant ① ... 58a: SWIFT-based CB customer ① ...
④ Booking		PM debits the account of IB PM participant and credits the account (liquidity bridge) of the CB of CB customer
⑥ MT 202 from SWIFT to HAM	TRGTXECBccX (CB Customer Liquidity Bridge)	S: TRGTXECBLVP R: TRGTXECBccX
		Same message as ②
⑦ Booking		HAM debits the account (liquidity bridge) of the CB of CB customer and credits the account of the CB customer
⑧ MT 900 (<i>optional</i>) from HAM to CB of CB customer	TRGTXECBccX (CB Customer Liquidity Bridge)	S: TRGTXECBNLX R: CB of CB customer

2 Flow of payments/transactions

2.1 Credit transfer

2.1.4 Credit transfer to a CB customer

		20: TRN by SSP 21: NEW 25: Account of CB of CB customer (debited) 32A: Value date, currency code and amount ... 52a: TRGTXEPLVP 72: /SETTIME/HHMMSSCC /INTERMOD/
⑨ MT 202 from HAM to CB customer		S: TRGTXECBccX R: SWIFT-based CB Customer BIC :
		20: TRN by SSP 21: Reference (21) from initial credit transfer ① 32A: Value date, currency code and amount ① ... 52a: //HAM+TRGTXEP0LVP+TRN ① ... Internet-based PM participant ① 58a: SWIFT-based CB customer ① ...
⑩ MT 910 (optional) from HAM to CB customer	TRGTXECBccX (CB Customer Liquidity Bridge)	S: TRGTXECBxxX R: CB customer
		20: TRN by SSP 21: Ref by SSP 25: Account of CB customer (debited) 32A: Value date, currency code and amount ... 52a: TRGTXEPLVP ... 56a: TRGTXECBccX

2 Flow of payments/transactions

2.1 Credit transfer

2.1.4 Credit transfer to a CB customer

2.1.4.5 From SWIFT-based CB customer to SWIFT-based CB Customer. Same CB

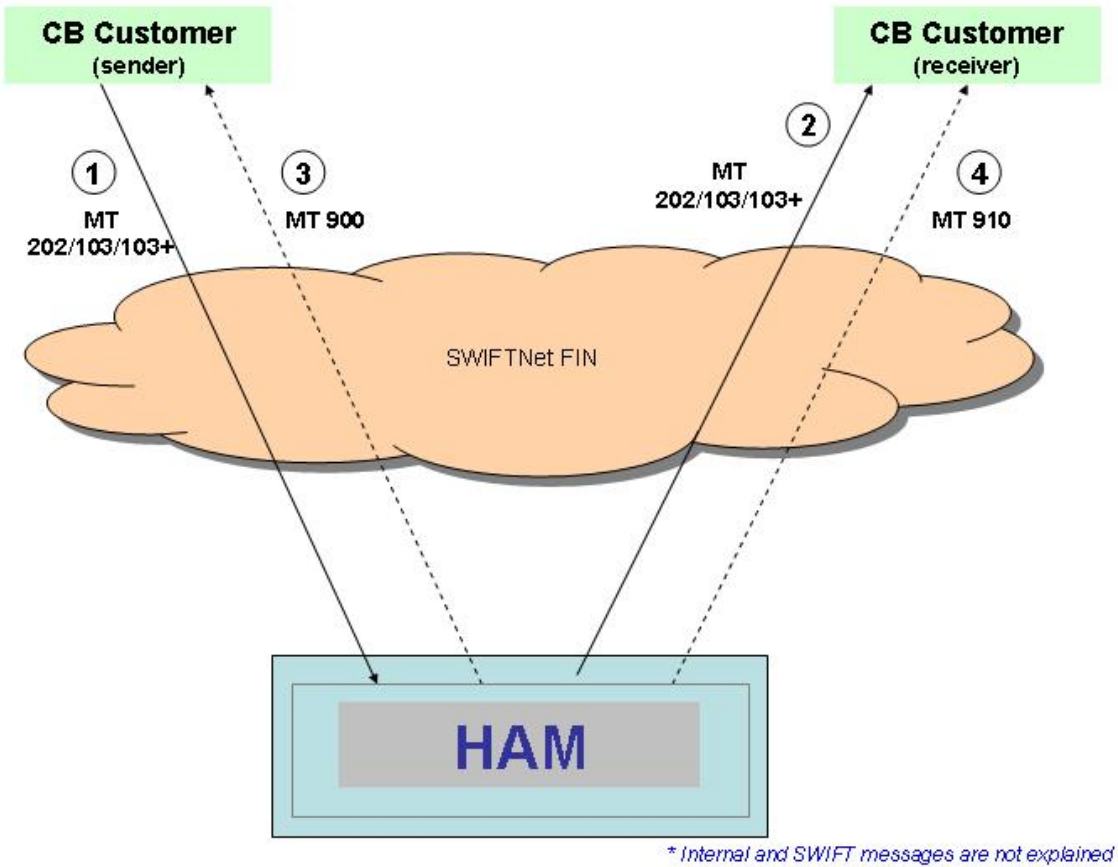

Message	BIC of respective SSP-Module	Field entry
① MT 202 from CB customer	TRGTXECCBccX (CB Customer)	S: CB customer (sender) R: TRGTXECCBccX

2 Flow of payments/transactions

2.1 Credit transfer

2.1.4 Credit transfer to a CB customer

		20: TRN 21: Related Reference 32A: Value date, currency code and amount ... 52a: CB customer (sender) ... 58a: CB customer (receiver) ...
② MT 202 from HAM to CB customer (receiver)	TRGTXEBCcX (CB Customer Liquidity Bridge)	S: TRGTXEBCcX R: CB customer (receiver)
		20: TRN 21: Related Reference (TRN of initial MT 202/103/103+ ①) 32A: Value date, currency code and amount ... 52a: //HAM+BIC of CB customer (sender)+ TRN (field 20) of initial MT 202/103/103+ ① CB customer (sender) ... 58a: CB customer (receiver) ...
③ MT 900 (optional) from HAM to CB customer (sender)	TRGTXEBCcX (CB Customer Liquidity Bridge)	S: TRGTXEBCcX R: CB customer (sender)
		20: TRN by SSP 21: Field 20 (TRN) of initial MT 202/103/103+ ① 25: Account of CB customer (sender) (debited) 32A: Value date, currency code and amount ... 52a: CB customer (sender) ...
④ MT 910 from HAM to CB customer (receiver)	TRGTXEBCcX (CB Customer Liquidity Bridge)	S: TRGTXEBCcX R: CB customer (receiver)
		20: TRN by SSP 21: Field 20 (TRN) of initial MT 202/103/103+ ① 25: Account of CB customer (receiver) (credited) 32A: Value date, currency code and amount ... 52a: CB customer (sender) ...

2 Flow of payments/transactions

2.1 Credit transfer

2.1.4 Credit transfer to a CB customer

2.1.4.6 From Internet-based CB customer to SWIFT-based CB customer.
Same CB

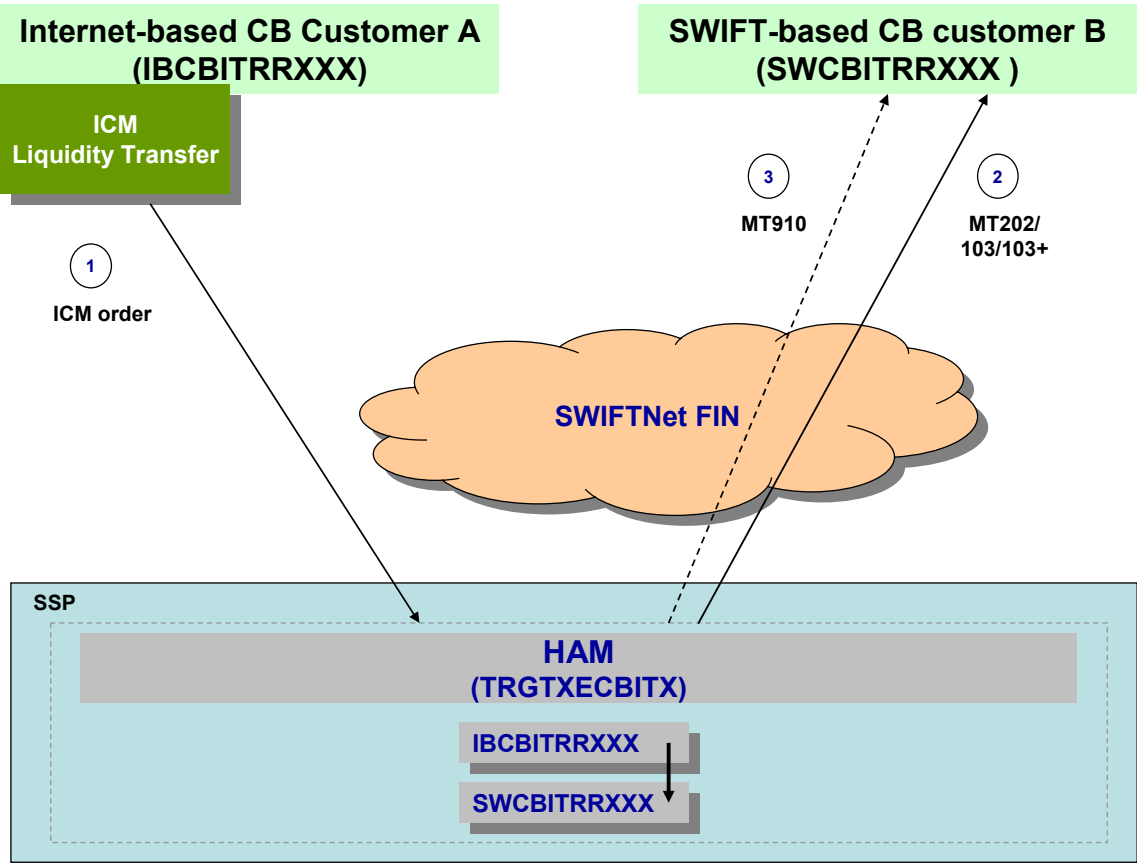

* Internal messages are not explained

Message	BIC of respective SSP-Module	Field entry
① ICM: Credit Transfer: Enter MT202 from CB customer A	N/A	S: N/A R: TRGTXEBCccX 113 Bank Priority

2 Flow of payments/transactions

2.1 Credit transfer

2.1.4 Credit transfer to a CB customer

		20: TRN 21: Related Reference 32A: Value date, currency code and amount ... 52a: CB customer A (sender) ... 58a: SWIFT-based CB customer (receiver) ...
② MT 202 from HAM to CB customer (receiver)	TRGTXECBccX (CB Customer Liquidity Bridge)	S: TRGTXECBccX R: CB customer (receiver)
		20: TRN 21: Related Reference (TRN of initial MT 202/103/103+ ①) 32A: Value date, currency code and amount ... 52a: //HAM+BIC of CB customer (sender)+ TRN (field 20) of initial MT 202/103/103+ ① CB customer (sender) ... 58a: CB customer (receiver) ...
③ MT 910 from HAM to CB customer (receiver)	TRGTXECBccX (CB Customer Liquidity Bridge)	S: TRGTXECBccX R: CB customer (receiver)
		20: TRN by SSP 21: Field 20 (TRN) of initial MT 202/103/103+ ① 25: Account of CB customer (receiver) (credited) 32A: Value date, currency code and amount ... 52a: CB customer (sender) ...

2 Flow of payments/transactions

2.1 Credit transfer

2.1.4 Credit transfer to a CB customer

2.1.4.7 From SWIFT-based CB customer to Internet-based CB customer.
Same CB

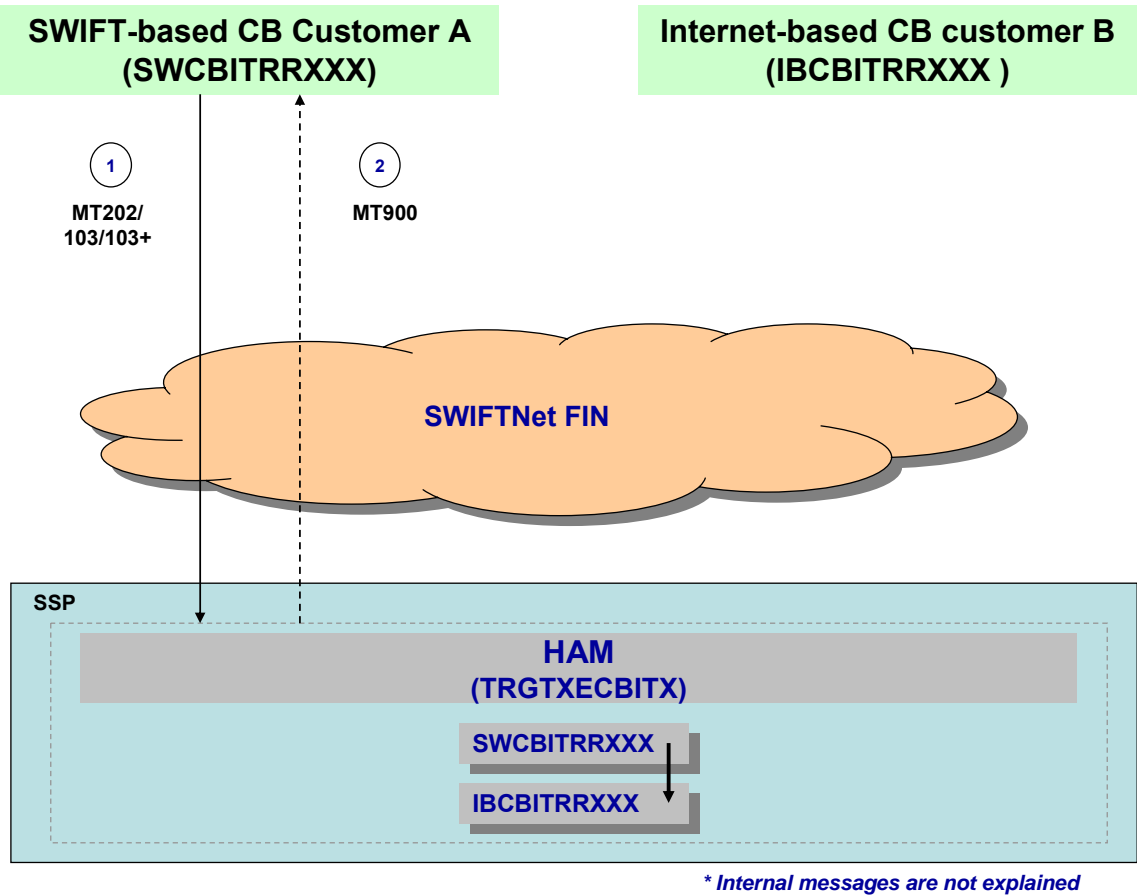

Message	BIC of respective SSP-Module	Field entry
① MT 202 from CB customer A (sender) to HAM	TRGTXECBccX (CB Customer Liquidity Bridge)	S: CB customer (sender) R: TRGTXECBccX 20: TRN 21: Related Reference 32A: Value date, currency code and amount ... 52a: CB customer A (sender) ... 58a: CB customer B (receiver) ...

2 Flow of payments/transactions

2.1 Credit transfer

2.1.4 Credit transfer to a CB customer

② MT 900 (<i>optional</i>) from HAM to CB customer (sender)	TRGTXECBccX (CB Customer Liquidity Bridge)	S: TRGTXECBccX R: CB customer (sender)
		20: TRN by SSP 21: Field 20 (TRN) of initial MT 202/103/103+ ① 25: Account of CB customer (sender) (debited) 32A: Value date, currency code and amount ... 52a: CB customer (sender) ...

2 Flow of payments/transactions

2.1 Credit transfer

2.1.4 Credit transfer to a CB customer

2.1.4.8 From Internet-based CB customer to Internet-based CB customer. Same CB

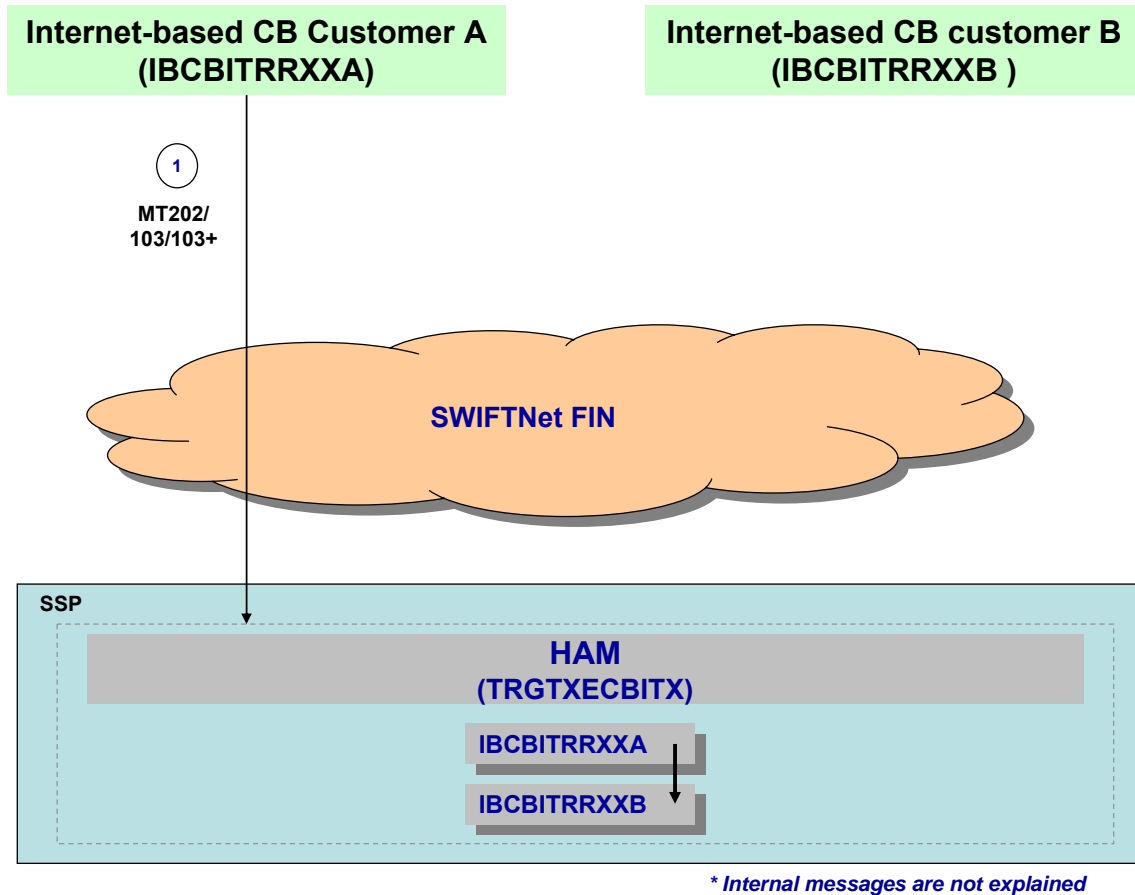

** Internal messages are not explained*

Message	BIC of respective SSP-Module	Field entry
① ICM: Credit Transfer: Enter MT202 from CB customer A (sender) to HAM	TRGTXECBccX (CB Customer Liquidity Bridge)	S: CB customer (sender) R: TRGTXECBccX 20: TRN 21: Related Reference 32A: Value date, currency code and amount ... 52a: CB customer A (sender) ... 58a: CB customer B (receiver) ...

2 Flow of payments/transactions

2.1 Credit transfer

2.1.4 Credit transfer to a CB customer

2.1.4.9 From SWIFT-based CB customer to SWIFT-based CB customer. Different CB

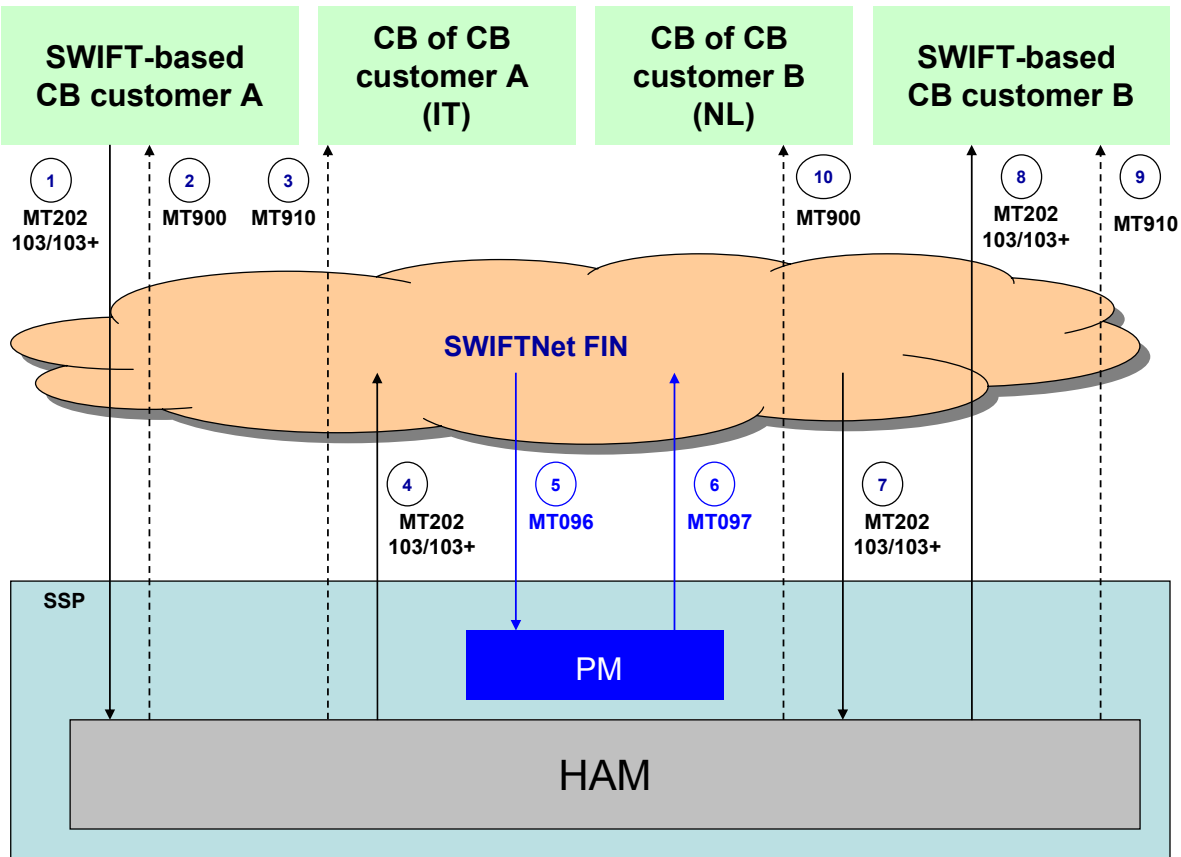

* Internal and MT096-MT097 messages are not explained

Message	BIC of respective SSP-Module	Field entry
① MT 202 from CB customer A	TRGTXECBITX (CB Customer)	S: CB customer A (sender) R: TRGTXECBITX

2 Flow of payments/transactions

2.1 Credit transfer

2.1.4 Credit transfer to a CB customer

		20: TRN 21: Related Reference 32A: Value date, currency code and amount ... 52a: CB customer A (sender) ... 58a: CB customer B (receiver) ...
② MT 900 (optional) from HAM to CB customer A (sender)	TRGTXEBCBITX (CB Customer Liquidity Bridge)	S: TRGTXEBCBITX R: CB customer A (sender)
		20: TRN by SSP 21: Field 20 (TRN) of initial MT 202/103/103+ ① 25: Account of CB customer A (sender) (debited) 32A: Value date, currency code and amount ... 52a: CB customer A (sender) ...
③ MT 910 (optional) from HAM to CB of CB customer A	TRGTXEBCBITX (CB Customer Liquidity Bridge)	S: TRGTXEBCBITX R: CB of CB customer A
		20: TRN by SSP 21: Field 20 (TRN) of initial MT 202/103/103+ ① 25: Account of CB of CB customer A (credited) 32A: Value date, currency code and amount ... 52a: CB customer A (sender) 72: /SETTIME/HHMMSSCC /INTERMOD/
④ MT 202 from HAM to CB customer B (receiver) via PM	TRGTXEBCBITX TRGTXEBCBNLX (CB Customer Liquidity Bridge)	S: TRGTXEBCBITX R: TRGTXEBCBNLX 103: TGT (service identifier)
		20: TRN 21: Field 20 (TRN) of initial MT 202/103/103+ ① 32A: Value date, currency code and amount ... 52a: //HAM+BIC of CB customer A (sender)+TRN (field 20) of initial MT 202/103/103+ ① CB customer A (sender) ... 58a: CB customer B (receiver) ...

2 Flow of payments/transactions

2.1 Credit transfer

2.1.4 Credit transfer to a CB customer

⑦ MT 202 from CB customer A (sender) to HAM	TRGTXEBCNLX (CB Customer Liquidity Bridge)	Message from ①
⑧ MT 202 from HAM to CB customer B (receiver)	TRGTXEBCNLX (CB Customer Liquidity Bridge)	<p>S: TRGTXEBCNLX (cc of receiving country) R: CB customer B</p> <p>20: TRN 21: Field 20 (TRN) of initial MT 202/103/103+ ④ 32A: Value date, currency code and amount ... 52a: CB customer A (sender) ... 58a: CB customer B (receiver)</p>
⑨ MT 910 (optional) from HAM to CB customer B (receiver)	TRGTXEBCNLX (CB Customer Liquidity Bridge)	<p>S: TRGTXEBCNLX R: CB customer B (receiver)</p> <p>20: TRN by SSP 21: Field 20 (TRN) of initial MT 202/103/103+ ④ 25: Account of the CB customer B (receiver) (credited) 32A: Value date, currency code and amount ... 52a: CB customer A (sender) ...</p>
⑩ MT 900 (optional) from HAM to CB of CB customer B	TRGTXEBCNLX (CB Customer Liquidity Bridge)	<p>S: TRGTXEBCNLX R: CB of CB customer B</p> <p>20: TRN by SSP 21: Field 20 (TRN) of initial MT 202/103/103+ ④ 25: Account of CB of CB customer B (debited) 32A: Value date, currency code and amount ... 52a: CB customer A (sender) 72: /SETTIME/HHMMSSCC /INTERMOD/</p>

2 Flow of payments/transactions

2.1 Credit transfer

2.1.4 Credit transfer to a CB customer

2.1.4.10 From Internet-based CB customer to SWIFT-based CB customer. Different CB.

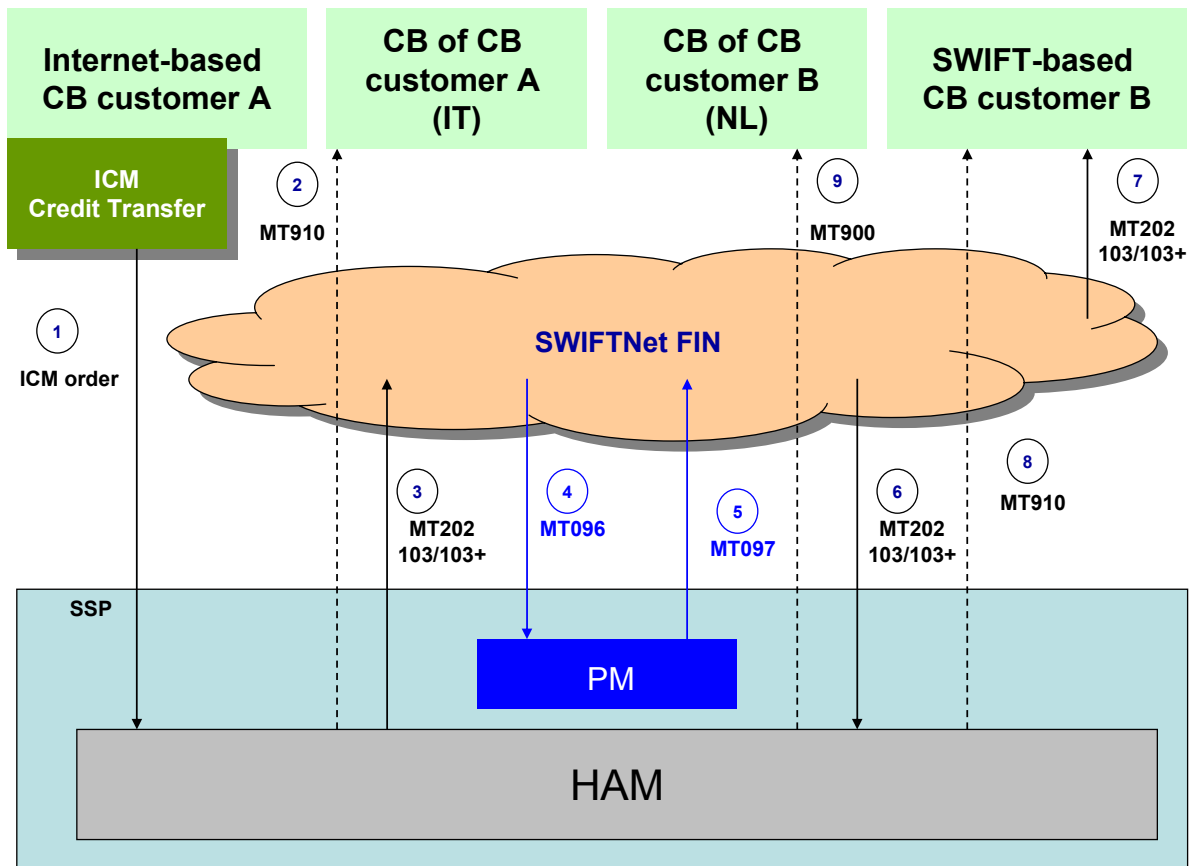

* Internal and MT096-MT097 messages are not explained

Message	BIC of respective SSP-Module	Field entry
① ICM: Credit Transfer: Enter MT202 from CB customer A	N/A	S: N/A R: TRGTXECBITX 113 Bank Priority

2 Flow of payments/transactions

2.1 Credit transfer

2.1.4 Credit transfer to a CB customer

		20: TRN 21: Related Reference 32A: Value date, currency code and amount ... 52a: Internet-based CB customer A ... 58a: SWIFT-based CB customer B (receiver) ...
② MT 910 (optional) from HAM to CB of CB customer A	TRGTXECSBITX (CB Customer Liquidity Bridge)	S: TRGTXECSBITX R: CB of CB customer A
		20: TRN by SSP 21: NEW 25: Account of CB of CB customer A (credited) 32A: Value date, currency code and amount ... 52a: CB customer A (sender) 72: /SETTIME/HHMMSSCC /INTERMOD/
③ MT 202 from HAM to CB customer B (receiver) via PM	TRGTXECSBITX TRGTXECSBNLX (CB Customer Liquidity Bridge)	S: TRGTXECSBITX R: TRGTXECSBNLX 103: TGT (service identifier)
		20: TRN 21: Field 21 (REF) of initial MT 202/103/103+ ① 32A: Value date, currency code and amount ... 52a: //HAM+BIC of CB customer A (sender)+TRN (field 20) of initial credit transfer ① CB customer A (sender) ... 58a: CB customer B (receiver) ...
		20: TRN 21: Field 20 (TRN) of initial MT 202/103/103+ ④ 25: Account of CB of CB customer B (debited) 32A: Value date, currency code and amount ... 52a: CB customer A (sender) ...

2 Flow of payments/transactions

2.1 Credit transfer

2.1.4 Credit transfer to a CB customer

⑥ MT 202 from CB customer A (sender) to HAM	TRGTXEBCNLX (CB Customer Liquidity Bridge)	Message via ICM. Credit Transfer from ①
⑦ MT 202 from HAM to CB customer B (receiver)	TRGTXEBCNLX (CB Customer Liquidity Bridge)	S: TRGTXEBCNLX (cc of receiving country) R: CB customer B
		20: TRN by SSP 21: Field 21 (REF) of initial MT 202/103/103+ ④ 32A: Value date, currency code and amount ... 52a: //HAM+BIC of CB customer A (sender)+TRN ... (field 20) from ③ CB customer A (sender) 58a: CB customer B (receiver)
⑧ MT 910 (optional) from HAM to CB customer B (receiver)	TRGTXEBCNLX (CB Customer Liquidity Bridge)	S: TRGTXEBCNLX R: CB customer B (receiver)
		20: TRN by SSP 21: REF by SSP 25: Account of the CB customer B (receiver) (credited) 32A: Value date, currency code and amount ... 52a: CB customer A (sender) ... 56a: TRGTXEBCNLX
⑨ MT 900 (optional) from HAM to CB of CB customer B	TRGTXEBCNLX (CB Customer Liquidity Bridge)	S: TRGTXEBCNLX R: CB of CB customer B
		20: TRN by SSP 21: Field 20 (TRN) of initial MT 202/103/103+ ④ 25: Account of CB of CB customer B (debited) 32A: Value date, currency code and amount ... 52a: CB customer A (sender) 72: /SETTIME/HHMMSSCC /INTERMOD/

2 Flow of payments/transactions

2.1 Credit transfer

2.1.4 Credit transfer to a CB customer

2.1.4.11 From SWIFT-based CB customer to Internet-based CB customer. Different CB.

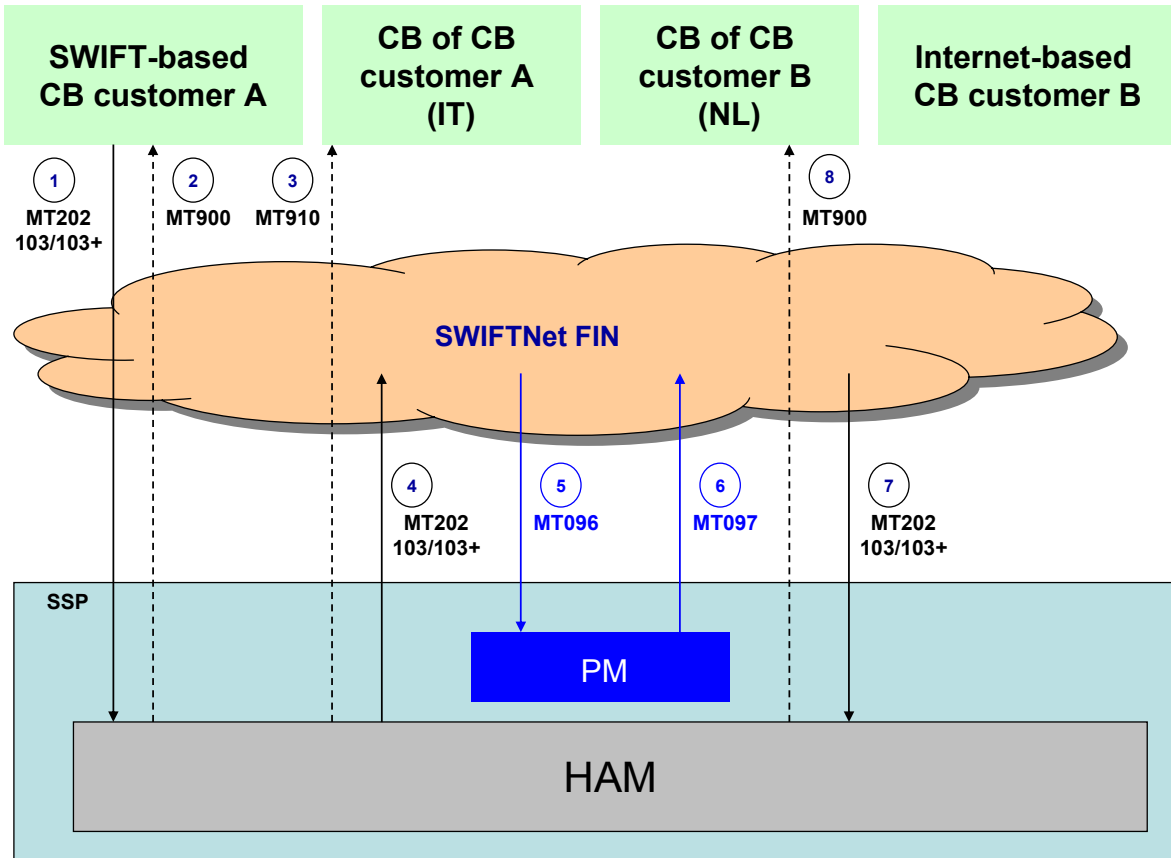

* Internal and MT096-MT097 messages are not explained

Message	BIC of respective SSP-Module	Field entry
① MT 202 from CB customer A (sender) to HAM	TRGTXECBITX (CB Customer Liquidity Bridge)	S: CB customer A (sender) R: TRGTXECBITX

2 Flow of payments/transactions

2.1 Credit transfer

2.1.4 Credit transfer to a CB customer

		20: TRN 21: Related Reference 32A: Value date, currency code and amount ... 52a: SWIFT-based CB customer A (sender) ... 58a: Internet-based CB customer B (beneficiary) ...
② MT 900 (optional) from HAM to CB customer A (sender)	TRGTXEBCccX (CB Customer Liquidity Bridge)	S: TRGTXECBITX R: CB customer A (sender)
		20: TRN by SSP 21: Field 20 (TRN) of initial MT 202/103/103+ ① 25: Account of CB customer A (sender) (debited) 32A: Value date, currency code and amount ... 52a: CB customer A (sender) ...
③ MT 910 (optional) from HAM to CB of CB customer A	TRGTXEBCccX (CB Customer Liquidity Bridge)	S: TRGTXECBITX R: CB of CB customer A
		20: TRN by SSP 21: Field 20 (TRN) of initial MT 202/103/103+ ① 25: Account of CB of CB customer A (credited) 32A: Value date, currency code and amount ... 52a: CB customer A (sender) 72: /SETTIME/HHMMSSCC /INTERMOD/
④ MT 202 from HAM to CB customer B (receiver) via PM	TRGTXEBCccX (CB Customer Liquidity Bridge)	S: TRGTXECBITX R: TRGTXECBNLX 103: TGT (service identifier)

2 Flow of payments/transactions

2.1 Credit transfer

2.1.4 Credit transfer to a CB customer

		20: TRN 21: Field 20 (TRN) of initial MT 202/103/103+ ① 32A: Value date, currency code and amount ... 52a: //HAM+BIC of CB customer A (sender)+TRN (field 20) of initial MT 202/103/103+ ① CB customer A (sender) ... 58a: CB customer B (receiver) ...
⑦ MT 202 from SWIFT to HAM	TRGTXECBccX (CB Customer Liquidity Bridge)	S: Message from ④ assigned to HAM (not delivered to Internet-based CB customer) R:
⑧ MT 900 (optional) from HAM to CB of CB customer B	TRGTXECBccX (CB Customer Liquidity Bridge)	S: TRGTXECBNLX R: CB of CB customer B
		20: TRN by SSP 21: Field 20 (TRN) of initial MT 202/103/103+ ④ 25: Account of CB of CB customer B (debited) 32A: Value date, currency code and amount ... 52a: CB customer A (sender) 72: /SETTIME/HHMMSSCC /INTERMOD/

2 Flow of payments/transactions

2.1 Credit transfer

2.1.4 Credit transfer to a CB customer

2.1.4.12 From Internet-based CB customer to Internet-based CB customer. Different CB.

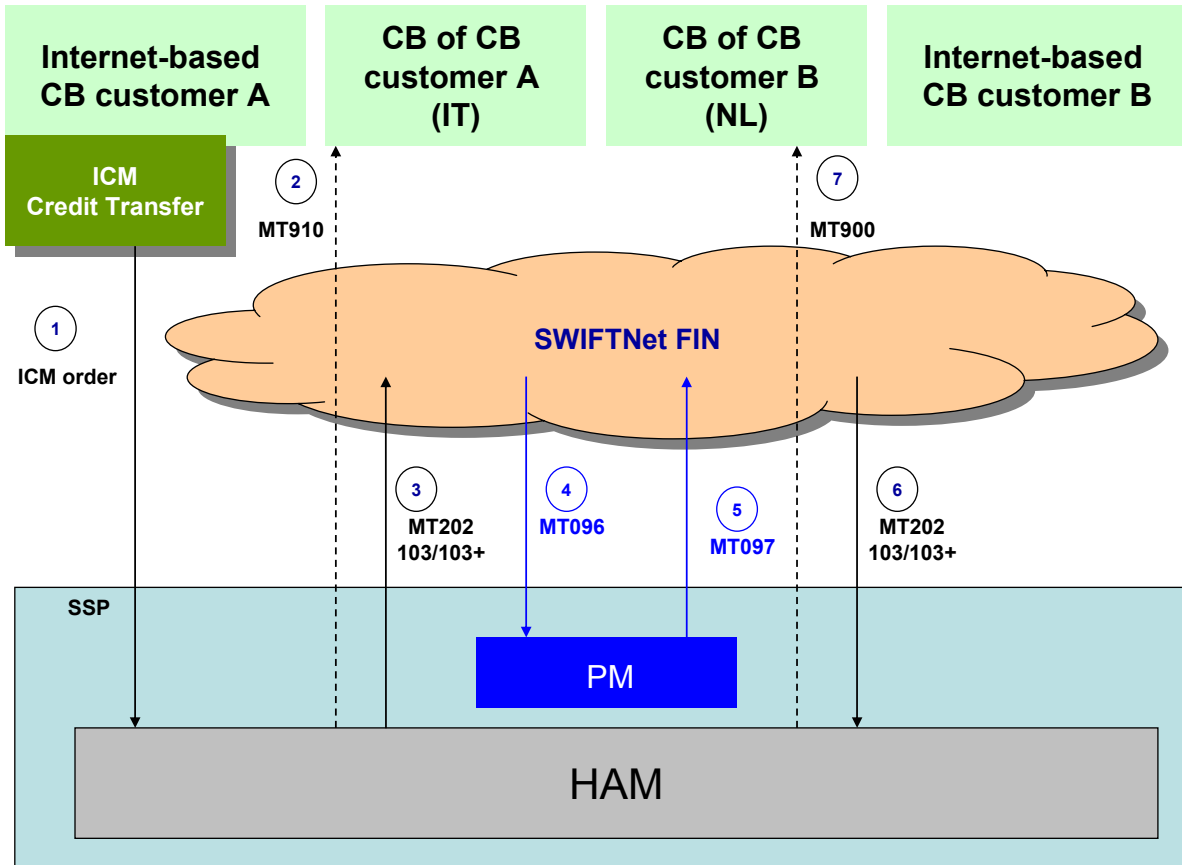

* Internal and MT096-MT097 messages are not explained

Message	BIC of respective SSP-Module	Field entry
① ICM: Credit Transfer: Enter MT202 from CB customer A	N/A	S: N/A R: TRGTXECBITX 113 Bank Priority

2 Flow of payments/transactions

2.1 Credit transfer

2.1.4 Credit transfer to a CB customer

		20: TRN 21: Related Reference 32A: Value date, currency code and amount ... 52a: Internet-based CB customer A ... 58a: Internet-based CB customer B (receiver) ...
② MT 910 (optional) from HAM to CB of CB customer A	TRGTXEBCBITX (CB Customer Liquidity Bridge)	S: TRGTXEBCBITX R: CB of CB customer A
		20: TRN by SSP 21: Field 20 (TRN) of initial MT 202/103/103+ ① 25: Account of CB of CB customer A (credited) 32A: Value date, currency code and amount 52a: CB customer A (sender) 72: /SETTIME/HHMMSSCC /INTERMOD/
③ MT 202 from HAM to CB customer B (receiver) via PM	TRGTXEBCBITX TRGTXEBCBNLX (CB Customer Liquidity Bridge)	S: TRGTXEBCBITX R: TRGTXEBCBNLX 103: TGT (service identifier)
		20: TRN 21: TRN 32A: Field 20 (TRN) of initial MT 202/103/103+ ① ... Value date, currency code and amount 52a: //HAM+BIC of CB customer A (sender)+TRN (field 20) of initial MT 202/103/103+ ① ... CB customer A (sender) 58a: ... CB customer B (receiver)
⑥ MT 202 From SWIFT to HAM	TRGTXEBCBNLX (CB Customer Liquidity Bridge)	Message from ③ assigned to HAM (not delivered to Internet-based CB customer)
⑦ MT 900 (optional) from HAM to CB of CB customer B	TRGTXEBCBNLX (CB Customer Liquidity Bridge)	S: TRGTXEBCBNLX R: CB of CB customer B
		20: TRN by SSP 21: Field 20 (TRN) of initial MT 202/103/103+ ④ 25: Account of CB of CB customer B (debited) 32A: Value date, currency code and amount 52a: CB customer A (sender) 72: /SETTIME/HHMMSSCC /INTERMOD/

2 Flow of payments/transactions

2.2 Liquidity transfer/Interbank transfer

2.2.1 Liquidity transfer with HAM

2.2 Liquidity transfer/Interbank transfer

2.2.1 Liquidity transfer with HAM

2.2.1.1 Liquidity transfer from SWIFT-based PM participant to HAM via ICM

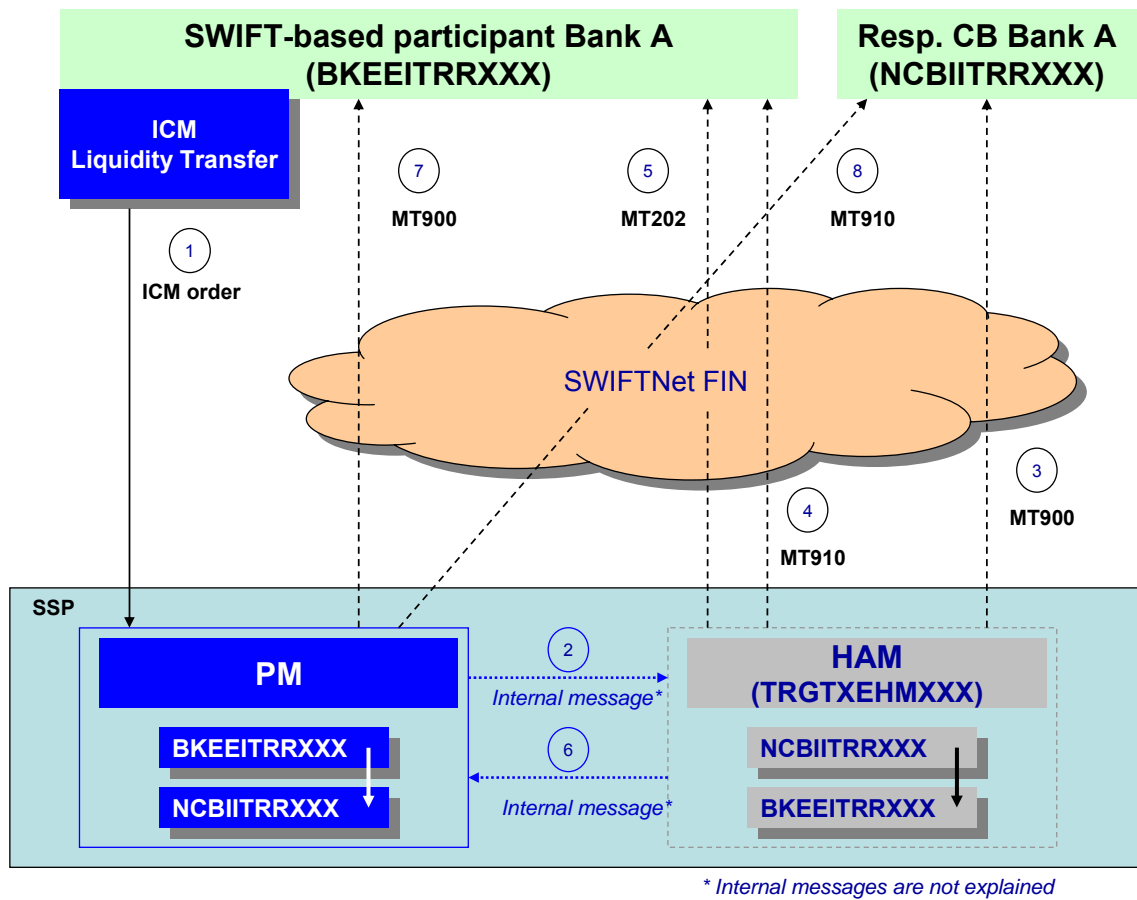

Message	BIC of respective SSP-Module	Field entry
① ICM order	N/A	S: N/A R: N/A
		Screen "Enter Liquidity Transfer". Click on arrow from RTGS account to HAM account Amount

2 Flow of payments/transactions

2.2 Liquidity transfer/Interbank transfer

2.2.1 Liquidity transfer with HAM

Message	BIC of respective SSP-Module	Field entry
③ MT 900 (optional) from HAM to the CB	TRGTXE HMXXX (SSP-BIC of HAM)	S: TRGTXEHMXXX R: CB (NCBIITRRXXX) 20: TRN by SSP 21: "NEW" 25: CB's HAM account identification 32A: Value date, currency code and amount ... 52a: Bank A (BKEEITRRXXX), "Ordering Institution" ① ... 72: /SETTIME/HHMMSSCC /INTERMOD/
④ MT 910 (optional) from HAM to Bank A	TRGTXE HMXXX (SSP-BIC of HAM)	S: TRGTXEHMXXX R: Bank A (BKEEITRRXXX) 20: TRN by SSP 21: "NEW" 25: HAM account identification of Bank A 32A: Value date, currency code and amount ... 52a: Bank A (BKEEITRRXXX), "Ordering Institution" ① ... 72: /SETTIME/HHMMSSCC
⑤ MT 202 (optional) from HAM to Bank A	TRGTXE HMXXX (SSP-BIC of HAM)	S: TRGTXEHMXXX R: Bank A (BKEEITRRXXX) 20: TRN by SSP 21: "NEW" 32A: Value date, currency code and amount ... 52a: Bank A (BKEEITRRXXX), "Ordering Institution" ① 58a Bank A (BKEEITRRXXX), "Beneficiary" ① :
⑦ MT 900 (optional) from PM to Bank A	TRGTXEPMXXX (SSP-BIC of PM)	S: TRGTXEPMXXX R: Bank A (BKEEITRRXXX)

2 Flow of payments/transactions

2.2 Liquidity transfer/Interbank transfer

2.2.1 Liquidity transfer with HAM

Message	BIC of respective SSP-Module	Field entry
		20: TRN by SSP 21: Related Reference by SSP (same as TRN) 25: RTGS account identification of Bank A 32A: Value date, currency code and amount ... 52a: Bank A (BKEEITRRXXX), "Ordering Institution" ① ... 72: /SETTIME/HHMMSSCC /LIQUIOUT/
⑧ MT 910 (optional) from PM to the CB	TRGTXEPMXXX (SSP-BIC of PM)	S: TRGTXEPMXXX R: CB (NCBIITRRXXX)
		20: TRN by SSP 21: Related Reference by SSP (same as TRN) 25: CB's RTGS account identification 32A: Value date, currency code and amount ... 52a: Bank A (BKEEITRRXXX), "Ordering Institution" ① ... 72: /SETTIME/HHMMSSCC /LIQUIOUT/

2 Flow of payments/transactions

2.2 Liquidity transfer/Interbank transfer

2.2.1 Liquidity transfer with HAM

2.2.1.2 Liquidity transfer from PM participant to HAM via SWIFT FIN payment

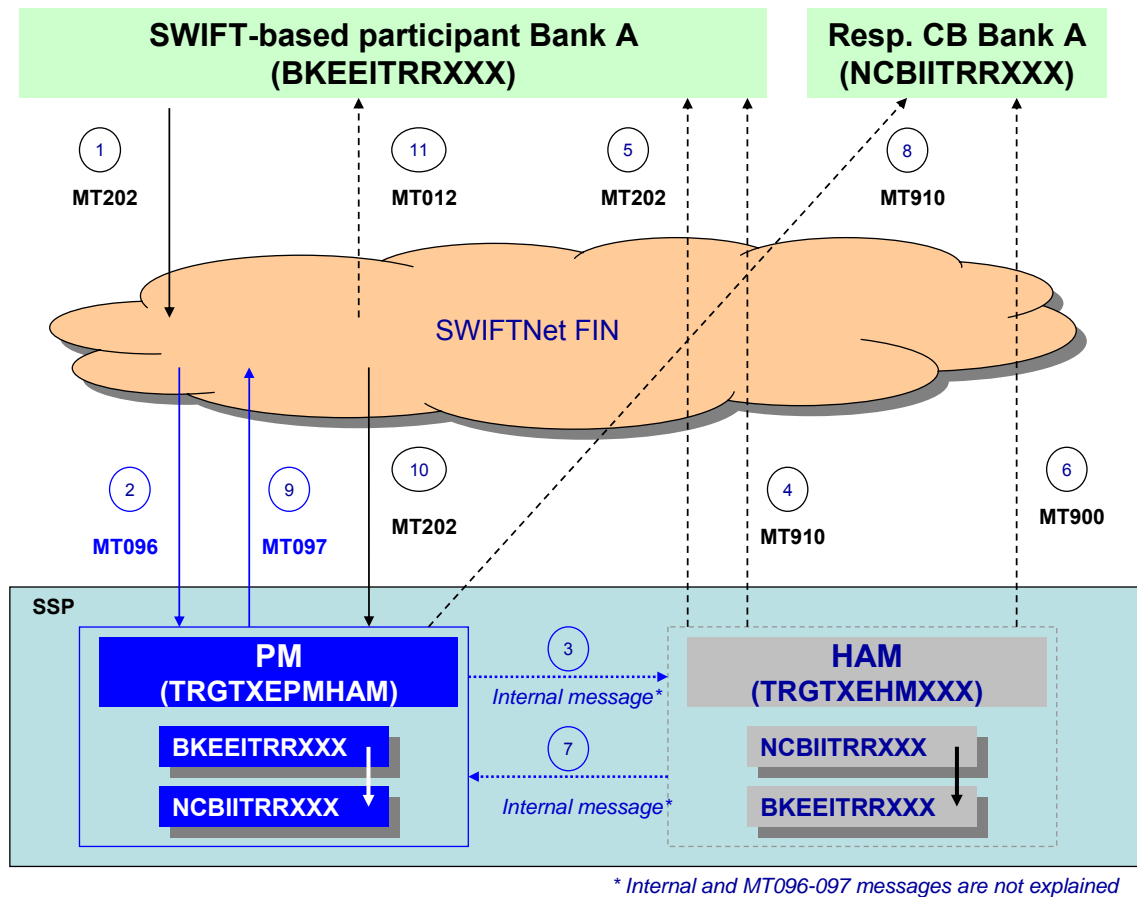

Message	BIC of respective SSP-Module	Field entry
① MT 202 from PM account to HAM account (same participant)	TRGTXP MHAM (CB Customer Liquidity Bridge)	S: BKEEITRRXXX R: TRGTXP MHAM 103: TGT (service identifier)
		20: TRN 21: Related reference 32A: Value date, currency code and amount ... 52a: BKEEITRRXXX (Bank A) ... 58a: BKEEITRRXXX (Bank A)

2 Flow of payments/transactions

2.2 Liquidity transfer/Interbank transfer

2.2.1 Liquidity transfer with HAM

Message	BIC of respective SSP-Module	Field entry
④ MT 910 (optional) from HAM to Bank A	TRGTXE HMXXX (SSP-BIC of HAM)	S: TRGTXEHMXXX R: Bank A (BKEEITRRXXX) 20: TRN by SSP 21: Related reference by SSP 25: HAM account identification of Bank A 32A: Value date, currency code and amount ... 52a: Bank A (BKEEITRRXXX), "Ordering Institution" ① ... 56a: CB's BIC (NCBIITRRXXX) 72: /SETTIME/HHMMSSCC
⑤ MT 202 (optional) from HAM to Bank A	TRGTXE HMXXX (SSP-BIC of HAM)	S: TRGTXEHMXXX R: Bank A (BKEEITRRXXX) 20: TRN by SSP 21: Related reference ① 32A: Value date, currency code and amount ... 52a: Bank A (BKEEITRRXXX), "Ordering Institution" ① 53a: CB's BIC (NCBIITRRXXX) 58a Bank A (BKEEITRRXXX), "Beneficiary" ① :
⑥ MT 900 (optional) from HAM to the CB	TRGTXE HMXXX (SSP-BIC of HAM)	S: TRGTXEHMXXX R: CB (NCBIITRRXXX) 20: TRN by SSP 21: NEW 25: CB's HAM account identification 32A: Value date, currency code and amount ... 52a: Bank A (BKEEITRRXXX), "Ordering Institution" ① 72: /SETTIME/HHMMSSCC /INTERMOD/

2 Flow of payments/transactions

2.2 Liquidity transfer/Interbank transfer

2.2.1 Liquidity transfer with HAM

Message	BIC of respective SSP-Module	Field entry
⑧ MT 910 (optional) from PM to the CB	TRGTXEPMXXX (SSP-BIC of PM)	20: TRN by SSP 21: Related Reference by SSP (same as TRN) 25: CB's RTGS account identification 32A: Value date, currency code and amount ... 52a: Bank A (BKEEITRRXXX), "Ordering Institution" ① ... 72: /SETTIME/HHMMSSCC /LIQUIOUT/
⑩ MT 202 sent by SWIFT to SSP-PM BIC		S: SWIFT system R: TRGTXEPMHAM Message ① assigned to PM
11 MT 012 (optional)		175: Input time of the initial MT 202 ① 106: Message Input Reference (MIR) of the initial MT 202 ① 108: Message User Reference (MUR) if filled, else: TRN of initial MT 202 ① 102: SWIFT address of receiver (complete 12 character destination) 103: TGT (service identifier) 114: Payment-release-information-sender (credit and debit time, country code of sender and reference of the initial MT 202 (field 20 ①))

2 Flow of payments/transactions

2.2 Liquidity transfer/Interbank transfer

2.2.1 Liquidity transfer with HAM

2.2.1.3 Liquidity transfer from Internet-based PM participant to HAM

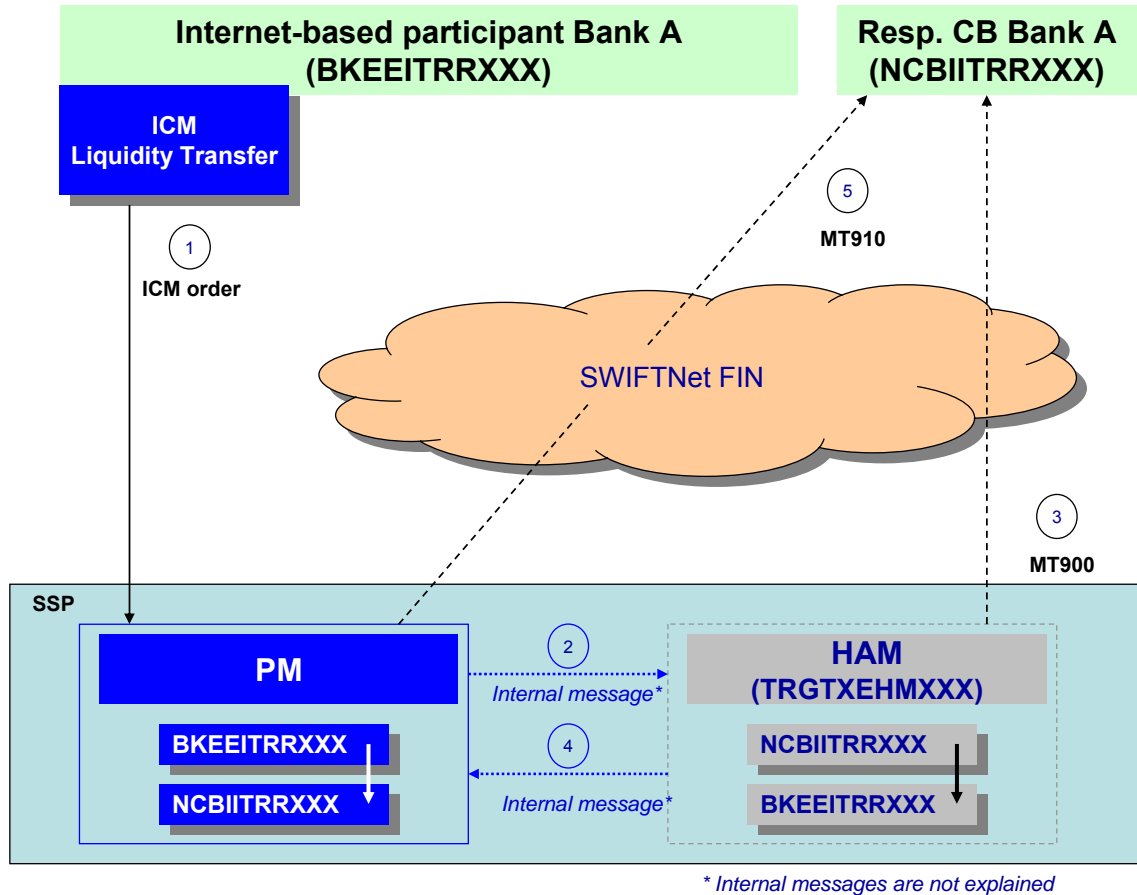

Message	BIC of respective SSP-Module	Field entry
① ICM order	N/A	S: N/A R: N/A
		Click on arrow from RTGS account to HAM account Amount
③ MT 900 (optional) from HAM to the CB	TRGTXE HMXXX (SSP-BIC of HAM)	S: TRGTXEHMXXX R: CB (NCBIITRRXXX)
		20: TRN by SSP

2 Flow of payments/transactions

2.2 Liquidity transfer/Interbank transfer

2.2.1 Liquidity transfer with HAM

Message	BIC of respective SSP-Module	Field entry
		21: "NEW" 25: CB's HAM account identification 32A: Value date, currency code and amount ... 52a: Bank A (BKEEITRRXXX), "Ordering Institution" ① ... 72: /SETTIME/HHMMSSCC /INTERMOD/
⑤ MT 910 (optional) from PM to the CB	TRGTXEPMXXX (SSP-BIC of PM)	S: TRGTXEPMXXX R: CB (NCBIITRRXXX) 20: TRN by SSP 21: Related Reference by SSP (same as TRN) 25: CB's RTGS account identification 32A: Value date, currency code and amount ... 52a: Bank A (BKEEITRRXXX), "Ordering Institution" ① ... 72: /LIQUIOUT/

2 Flow of payments/transactions

2.2 Liquidity transfer/Interbank transfer

2.2.1 Liquidity transfer with HAM

2.2.1.4 Liquidity transfer/Interbank transfer from HAM account holder to a direct PM Participant

2.2.1.4.1 Same participant (liquidity transfer), via SWIFT FIN payment.

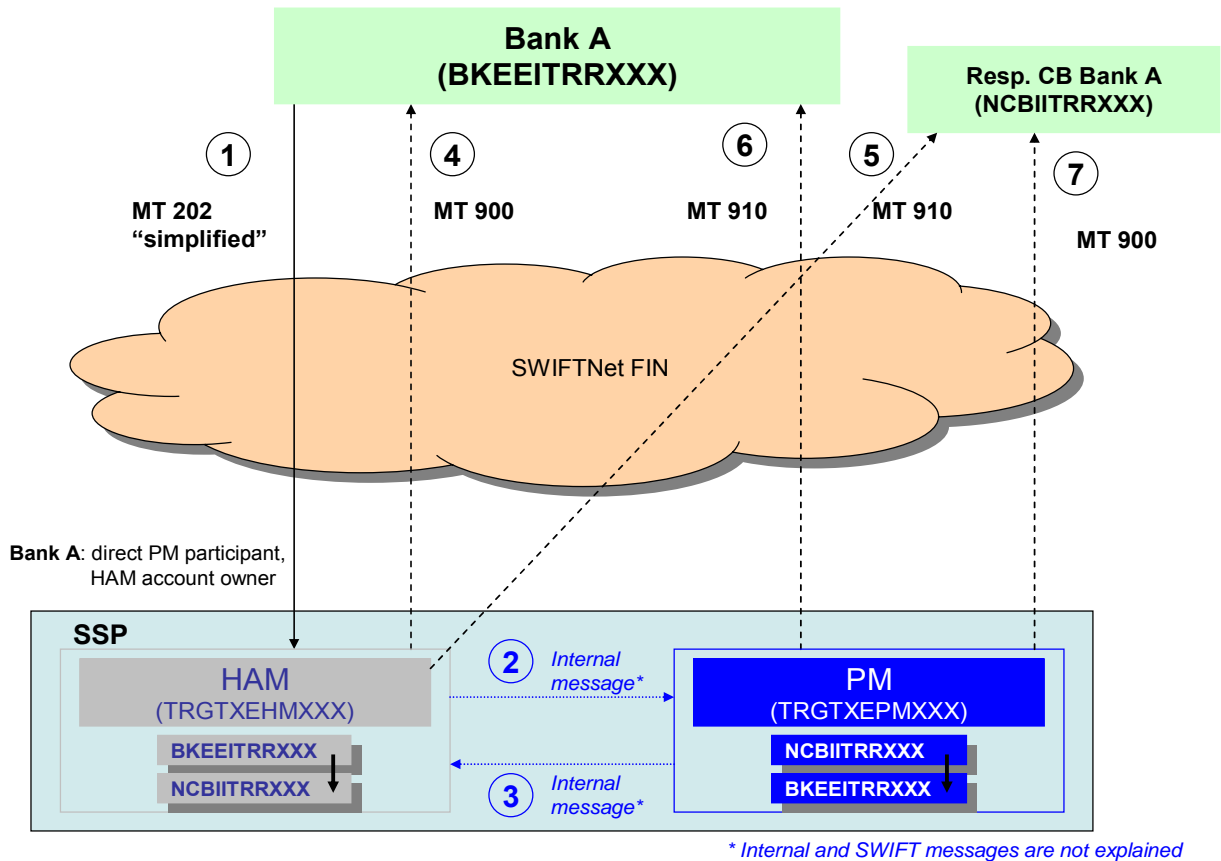

Message	BIC of respective SSP-Module	Field entry
① MT 202 "simplified" from Bank A to HAM	TRGTXEHMXXX (SSP-BIC of HAM)	S: Bank A (BKEEITRRXXX)
		R: TRGTXEHMXXX
		20: TRN (assigned by sender)

2 Flow of payments/transactions

2.2 Liquidity transfer/Interbank transfer

2.2.1 Liquidity transfer with HAM

Message	BIC of respective SSP-Module	Field entry
		21: Related Reference (assigned by sender) 32A: Value date, currency code and amount ... 57a: Debtor's CB (NCBIITRRXXX) 58a: Bank A (BKEEITRRXXX), creditor, Beneficiary Institution ...
④ MT 900 (optional) from HAM to sender of initial MT 202 "simplified" (only if the latter has chosen to receive it)	TRGTXE HMXXX (SSP-BIC of HAM)	S: TRGTXEHMXXX R: Bank A (BKEEITRRXXX) 20: TRN by SSP 21: Field 20 of initial MT 202 "simplified" ① 25: Account (which has been debited) Identification 32A: Value date, currency code and amount ... 52a: Bank A (BKEEITRRXXX), "Ordering Institution", sender of initial MT 202 "simplified" ① ... 72: /SETTIME/HHMMSSCC
⑤ MT 910 (optional) from HAM to the CB (only if the latter has chosen to receive it)	TRGTXE HMXXX (SSP-BIC of HAM)	S: TRGTXEHMXXX R: CB (NCBIITRRXXX) 20: TRN by SSP 21: "NEW" 25: Account (which has been credited) Identification 32A: Value date, currency code and amount ... 52a: Bank A (BKEEITRRXXX), "Ordering Institution", sender of initial MT 202 "simplified" ① ... 72: /SETTIME/HHMMSSCC /INTERMOD/
⑥ MT 910 (optional) from PM to creditor (only if creditor has chosen to receive it)	TRGTXEPMXXX (SSP-BIC of PM)	S: TRGTXEPMXXX R: Bank A (BKEEITRRXXX), field 58a of initial MT 202 "simplified" ① 20: TRN by SSP = field 20, 21 ⑥ 21: Field 21 (TRN) of initial MT 202 "simplified" ① 25: Account (which has been credited) Identification 32A: Value date, currency code and amount

2 Flow of payments/transactions

2.2 Liquidity transfer/Interbank transfer

2.2.1 Liquidity transfer with HAM

Message	BIC of respective SSP-Module	Field entry
		... 52a: BIC of the relevant CB (NCBIITRRXXX) ... 72: /LIQUIINP/
⑦ MT 900 (<i>optional</i>) from PM to the debtor's CB (only if the latter has chosen to receive it)	TRGTXEPMXXX (SSP-BIC of PM)	S: TRGTXEPMXXX R: Bank A (NCBIITRRXXX), field 58a of initial MT 202 "simplified" ① 20: TRN by SSP = field 20 ⑤ 21: = field 20 25: Account (which has been credited) Identification 32A: Value date, currency code and amount ... 52a: BIC of the relevant CB (NCBIITRRXXX) ... 72: /LIQUIINP/

2 Flow of payments/transactions

2.2 Liquidity transfer/Interbank transfer

2.2.1 Liquidity transfer with HAM

2.2.1.4.2 Same participant (liquidity transfer) ordered via ICM, clicking on button "Liquidity Transfers"

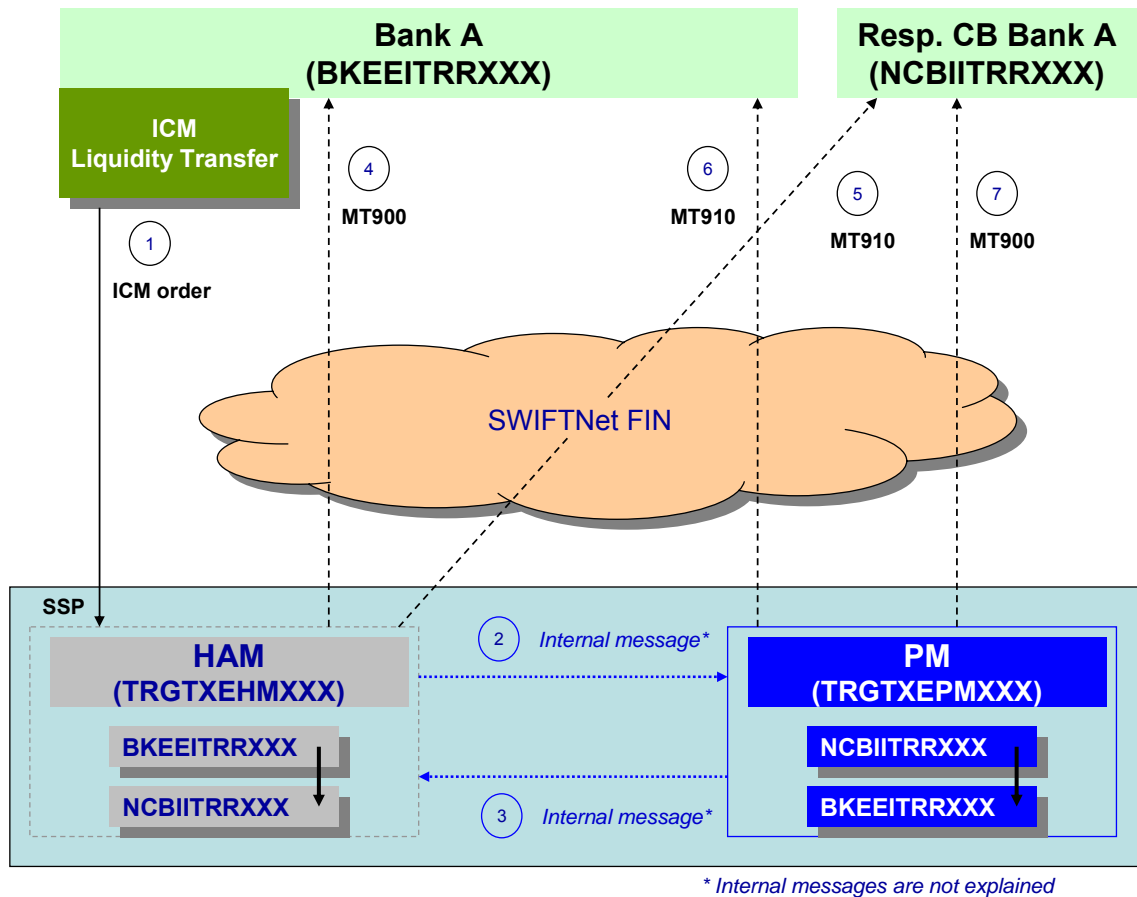

Message	BIC of respective SSP-Module	Field entry
① ICM order	N/A	S: N/A R: N/A
		Click on arrow from Home Account to RTGS Account Insert amount
④ MT 900 (optional) from HAM to participant	TRGTXE HMXXX (SSP-BIC of HAM)	S: TRGTXEHMXXX R: Bank A (BKEEITRRXXX)
		20: TRN by SSP

2 Flow of payments/transactions

2.2 Liquidity transfer/Interbank transfer

2.2.1 Liquidity transfer with HAM

Message	BIC of respective SSP-Module	Field entry
		21: Related Reference by SSP 25: Account (which has been debited) Identification 32A: Value date, currency code and amount ... 52a: Bank A (BKEEITRRXXX), "Ordering Institution", ① ... 72: /SETTIME/HHMMSSCC
⑤ MT 910 (optional) from HAM to the CB	TRGTXE HMXXX (SSP-BIC of HAM)	S: TRGTXEHMXXX R: CB (NCBIITRRXXX) 20: TRN by SSP 21: "NEW" 25: Account (which has been credited) Identification 32A: Value date, currency code and amount ... 52a: Bank A (BKEEITRRXXX), "Ordering Institution" ① ... 72: /SETTIME/HHMMSSCC /INTERMOD/
⑥ MT 910 (optional) from PM to creditor	TRGTXEPMXXX (SSP-BIC of PM)	S: TRGTXEPMXXX R: Bank A (BKEEITRRXXX), field 58a of initial MT 202 "simplified" ① 20: TRN by SSP 21: Related Reference by SSP 25: Account (which has been credited) Identification 32A: Value date, currency code and amount ... 52a: BIC of the relevant CB (NCBIITRRXXX) ... 72: /LIQUIINP/
⑦ MT 900 (optional) from PM to the debtor's CB	TRGTXEPMXXX (SSP-BIC of PM)	S: TRGTXEPMXXX R: Bank A (NCBIITRRXXX), field 58a of initial MT 202 "simplified" ① 20: TRN by SSP 21: Related Reference by SSP 25: Account (which has been debited)

2 Flow of payments/transactions

2.2 Liquidity transfer/Interbank transfer

2.2.1 Liquidity transfer with HAM

Message	BIC of respective SSP-Module	Field entry
		Identification 32A: Value date, currency code and amount ... 52a: BIC of the relevant CB (NCBIITRRXXX) ... 72: /LIQUIINP/

2 Flow of payments/transactions

2.2 Liquidity transfer/Interbank transfer

2.2.1 Liquidity transfer with HAM

2.2.1.4.3 Different participant (Interbank transfer), via SWIFT FIN payment.

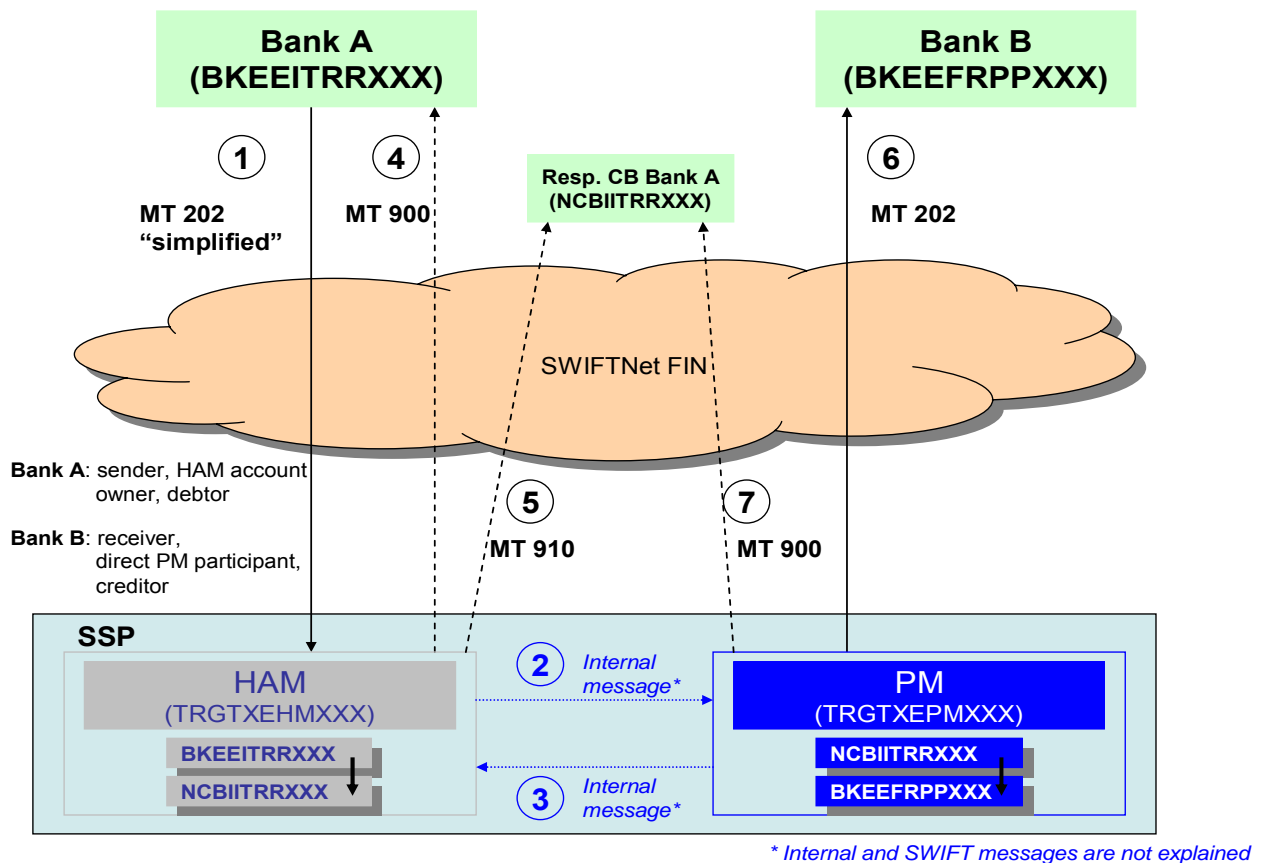

Message	BIC of respective SSP-Module	Field entry
① MT 202 „simplified“ from Bank A to HAM	TRGTXEHMXXX (SSP-BIC of HAM)	S: Bank A (BKEEITRRXXX), debtor R: TRGTXEHMXXX 20: TRN (assigned by sender) 21: Related Reference (assigned by sender) 32A: Value date, currency code and amount ... 57a: Debtor's CB (NCBIITRRXXX) 58a: Bank B (BKEEFRPPXXX), creditor, Beneficiary Institution ...

2 Flow of payments/transactions

2.2 Liquidity transfer/Interbank transfer

2.2.1 Liquidity transfer with HAM

Message	BIC of respective SSP-Module	Field entry
④ MT 900 (optional) from HAM to sender of initial MT 202 "simplified"	TRGTXEHMXXX (SSP-BIC of HAM)	S: TRGTXEHMXXX R: Bank A (BKEEITRRXXX), sender of initial MT 202 "simplified" ①
		20: TRN by SSP 21: Field 20 of initial MT 202 "simplified" ① 25: Account (which has been debited) Identification 32A: Value date and amount 52a: Bank A "(BKEEITRRXXX), "Ordering Institution", sender of initial MT 202 "simplified" ① 72: /SETTIME/HHMMSSCC
⑤ MT 910 (optional) from HAM to the CB of the debtor	TRGTXEHMXXX (SSP-BIC of HAM)	S: TRGTXEHMXXX R: NCBIITRRXXX, CB of the sender of initial MT 202 "simplified" ①
		20: TRN (assigned by SSP) 21: NEW 25: Account (which has been credited) Identification 32A: Value date and amount 52a: Bank A "(BKEEITRRXXX), "Ordering Institution", sender of initial MT 202 "simplified" ① 72: /SETTIME/HHMMSSCC /INTERMOD/
⑥ MT 202 from PM to PM participant, creditor	TRGTXEPMXXX (SSP-BIC of PM)	S: TRGTXEPMXXX R: Bank B (BKEEFRPPXXX), creditor, field 58a of initial MT 202 "simplified"
		20: TRN (assigned by SSP) = field 20, 21 ① 21: Related Reference, field 21 of initial MT 202 "simplified" ① 32A: Value date, currency code and amount ... 52a: Bank A (BKEEITRRXXX), "Ordering Institution", sender of initial MT 202 "simplified" ① 53a: Debtor's CB = "sender's correspondent" ... 58a: Bank B (BKEEFRPPXXX), field 58a of initial MT 202 "simplified" ① ...

2 Flow of payments/transactions

2.2 Liquidity transfer/Interbank transfer

2.2.1 Liquidity transfer with HAM

Message	BIC of respective SSP-Module	Field entry
⑦ MT 900 (<i>optional</i>) from PM to the CB of the debtor of the initial MT 202 "simplified"	TRGTXEPMXXX (SSP-BIC of PM)	S: TRGTXEPMXXX R: NCBIITRRXXX, CB of the sender of initial MT 202 "simplified" ①
		20: TRN by SSP = field 20 ④ 21: = field 20 25: Account (which has been debited) Identification ... 32A: Value date, currency code and amount ... 52a: Bank A (BKEEITRRXXX) "Ordering Institution", sender of initial MT 202 "simplified" ① ...

2 Flow of payments/transactions

2.2 Liquidity transfer/Interbank transfer

2.2.1 Liquidity transfer with HAM

2.2.1.5 Liquidity transfer/Interbank transfer from HAM account holder to a direct PM Participant ordered via ICM.

Note: Ordered via ICM clicking on button “Liquidity Transfers (other Accounts)”

2.2.1.5.1 Same CB

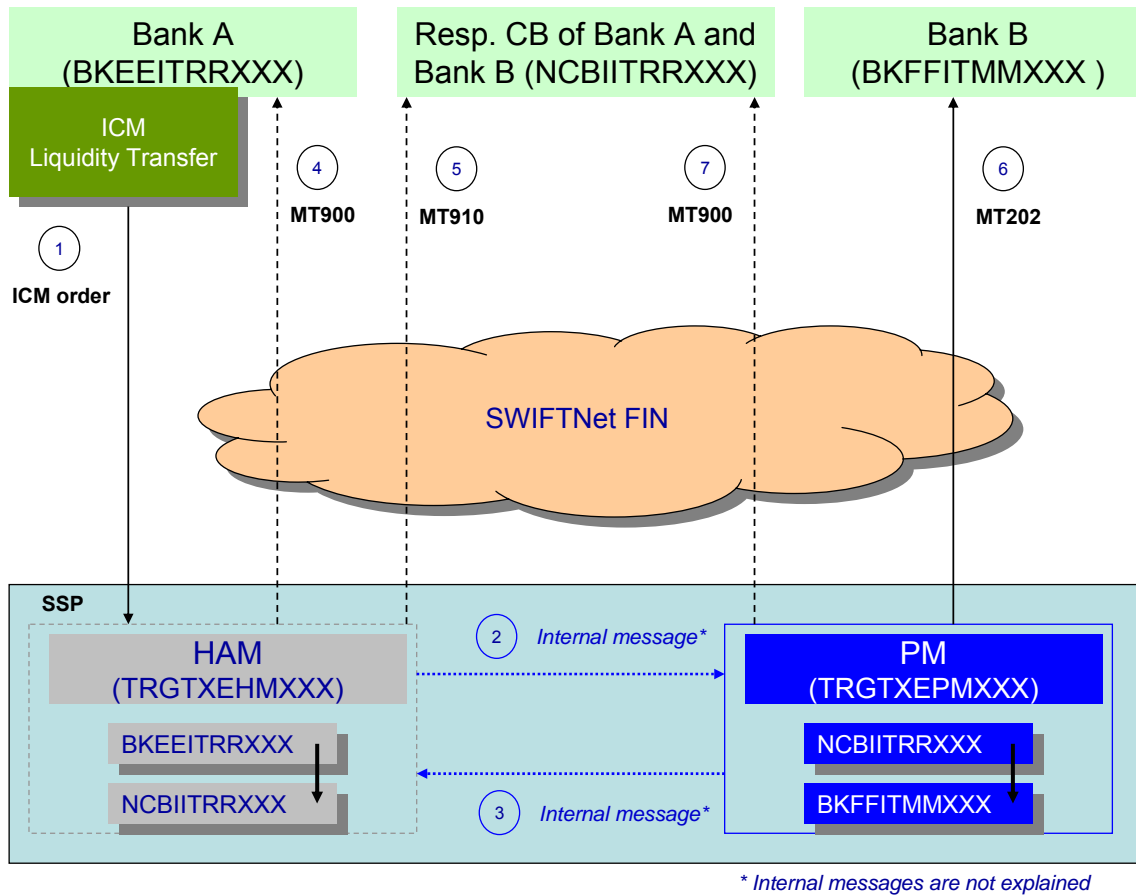

Message	BIC of respective SSP-Module	Field entry
① ICM order	N/A	S: N/A R: N/A
		Participant BIC: Ordering HAM account holder Bank A (BKEEITRRXXX)

2 Flow of payments/transactions

2.2 Liquidity transfer/Interbank transfer

2.2.1 Liquidity transfer with HAM

Message	BIC of respective SSP-Module	Field entry
		Counterpart for Liquidity Transfer - Participant BIC: Bank B (BKFFITMMXXX), creditor, Beneficiary Institution - Module: RTGS - Responsible CB: CB's Country Code of the counterpart (IT) - Liquidity transfer (EUR): amount
④ MT 900 (optional) from HAM to ordering HAM account holder	TRGTXEHMXXX (SSP-BIC of HAM)	S: TRGTXEHMXXX R: Bank A (BKEEITRRXXX), ordering HAM account holder ①
		20: TRN by SSP 21: Related Reference by SSP 25: Account (which has been debited) Identification 32A: Value date and amount ... 52a: Bank A "(BKEEITRRXXX), "Ordering Institution", via ICM ... 72: /SETTIME/HHMMSSCC
⑤ MT 910 (optional) from HAM to the CB of the debtor	TRGTXEHMXXX (SSP-BIC of HAM)	S: TRGTXEHMXXX R: NCBIITRRXXX, CB of Ordering HAM account holder ①
		20: TRN (assigned by SSP) 21: NEW 25: Account (which has been credited) Identification 32A: Value date and amount ... 52a: Bank A "(BKEEITRRXXX), "Ordering Institution", via ICM ① ... 72: /SETTIME/HHMMSSCC /INTERMOD/
⑥ MT 202 from PM to PM participant, creditor	TRGTXEPMXXX (SSP-BIC of PM)	S: TRGTXEPMXXX R: Bank B (BKFFITMMXXX), Counterpart for Liquidity Transfer, Creditor, Beneficiary Institution
		20: TRN (assigned by SSP) 21: ICM

2 Flow of payments/transactions

2.2 Liquidity transfer/Interbank transfer

2.2.1 Liquidity transfer with HAM

Message	BIC of respective SSP-Module	Field entry
		32A: Value date, currency code and amount ... 52a: Bank A (BKEEITRRXXX), "Ordering Institution", via ICM ① 53a: Debtor's CB = "sender's correspondent". CB of HAM account holder (NCBIITRRXXX) ... 58a Bank B (BKFFITMMXXX), Counterpart for Liquidity Transfer ① ...
⑦ MT 900 (<i>optional</i>) from PM to the CB of the debtor of the initial ICM order"	TRGTXEPMXXX (SSP-BIC of PM)	S: TRGTXEPMXXX R: NCBIITRRXXX, CB of the Counterpart for Liquidity Transfer ①
		20: TRN by SSP 21: Related reference by SSP 25: Account (which has been debited) Identification ... 32A: Value date, currency code and amount ... 52a: Bank A (BKEEITRRXXX) "Ordering Institution", ordering HAM account holder via ICM ① ...

2 Flow of payments/transactions

2.2 Liquidity transfer/Interbank transfer

2.2.1 Liquidity transfer with HAM

2.2.1.5.2 Different CB

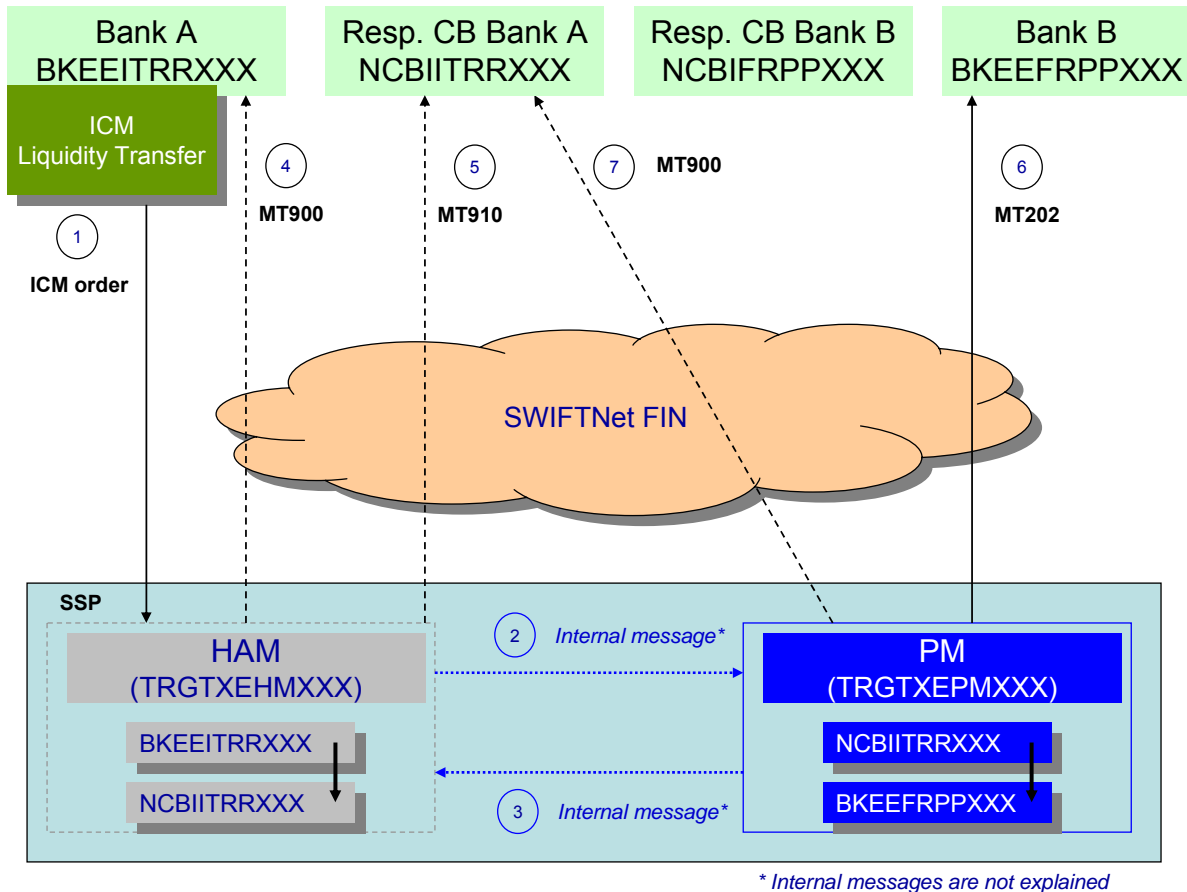

Message	BIC of respective SSP-Module	Field entry
① ICM order	N/A	<p>S: N/A R: N/A</p> <p>Participant BIC: Ordering HAM account holder Bank A (BKEEITRRXXX)</p> <p>Counterpart for Liquidity Transfer</p> <ul style="list-style-type: none"> - Participant BIC: Bank B (BKEEFRPPXXX), creditor, Beneficiary Institution - Module: RTGS - Responsible CB: CB's Country Code of the counterpart (FR) - Liquidity transfer (EUR): amount

2 Flow of payments/transactions

2.2 Liquidity transfer/Interbank transfer

2.2.1 Liquidity transfer with HAM

Message	BIC of respective SSP-Module	Field entry
④ MT 900 (optional) from HAM to ordering HAM ...account holder	TRGTXEHMXXX (SSP-BIC of HAM)	S: TRGTXEHMXXX R: Bank A (BKEEITRRXXX), ordering HAM account holder ①
		20: TRN by SSP 21: Related reference by SSP 25: Account (which has been debited) Identification 32A: Value date and amount ... 52a: Bank A "(BKEEITRRXXX), "Ordering Institution", via ICM ... 72: /SETTIME/HHMMSSCC
⑤ MT 910 (optional) from HAM to the CB of the debtor	TRGTXEHMXXX (SSP-BIC of HAM)	S: TRGTXEHMXXX R: NCBIITRRXXX, CB of Ordering HAM account holder ①
		20: TRN (assigned by SSP) 21: NEW 25: Account (which has been credited) Identification 32A: Value date and amount ... 52a: Bank A "(BKEEITRRXXX), "Ordering Institution" via ICM ① ... 72: /SETTIME/HHMMSSCC /INTERMOD/
⑥ MT 202 from PM to PM participant, creditor	TRGTXEPMXXX (SSP-BIC of PM)	S: TRGTXEPMXXX R: Bank B (BKEEFRPPXXX), Counterpart for Liquidity Transfer, Creditor, Beneficiary Institution
		20: TRN (assigned by SSP) 21: ICM 32A: Value date, currency code and amount ... 52a: Bank A (BKEEITRRXXX), "Ordering Institution", via ICM ① 53a: Debtor's CB = "sender's correspondent". CB of HAM account holder (NCBIITRRXXX) ...

2 Flow of payments/transactions

2.2 Liquidity transfer/Interbank transfer

2.2.1 Liquidity transfer with HAM

Message	BIC of respective SSP-Module	Field entry
		58a Bank B (BKEEFRPPXXX), Counterpart for Liquidity Transfer ① ...
⑦ MT 900 (<i>optional</i>) from PM to the CB of the debtor of the initial ICM order"	TRGTXEPMXXX (SSP-BIC of PM)	S: TRGTXEPMXXX R: NCBIITRRXXX, CB of the Counterpart for Liquidity Transfer ①
		20: TRN by SSP 21: Related reference by SSP 25: Account (which has been debited) Identification ... 32A: Value date, currency code and amount ... 52a: Bank A (BKEEITRRXXX) "Ordering Institution", ordering HAM account holder via ICM ① ...

2 Flow of payments/transactions

2.2 Liquidity transfer/Interbank transfer

2.2.1 Liquidity transfer with HAM

2.2.1.6 Interbank transfer from HAM account holder to HAM account holder

2.2.1.6.1 Same CB, via SWIFT FIN payment

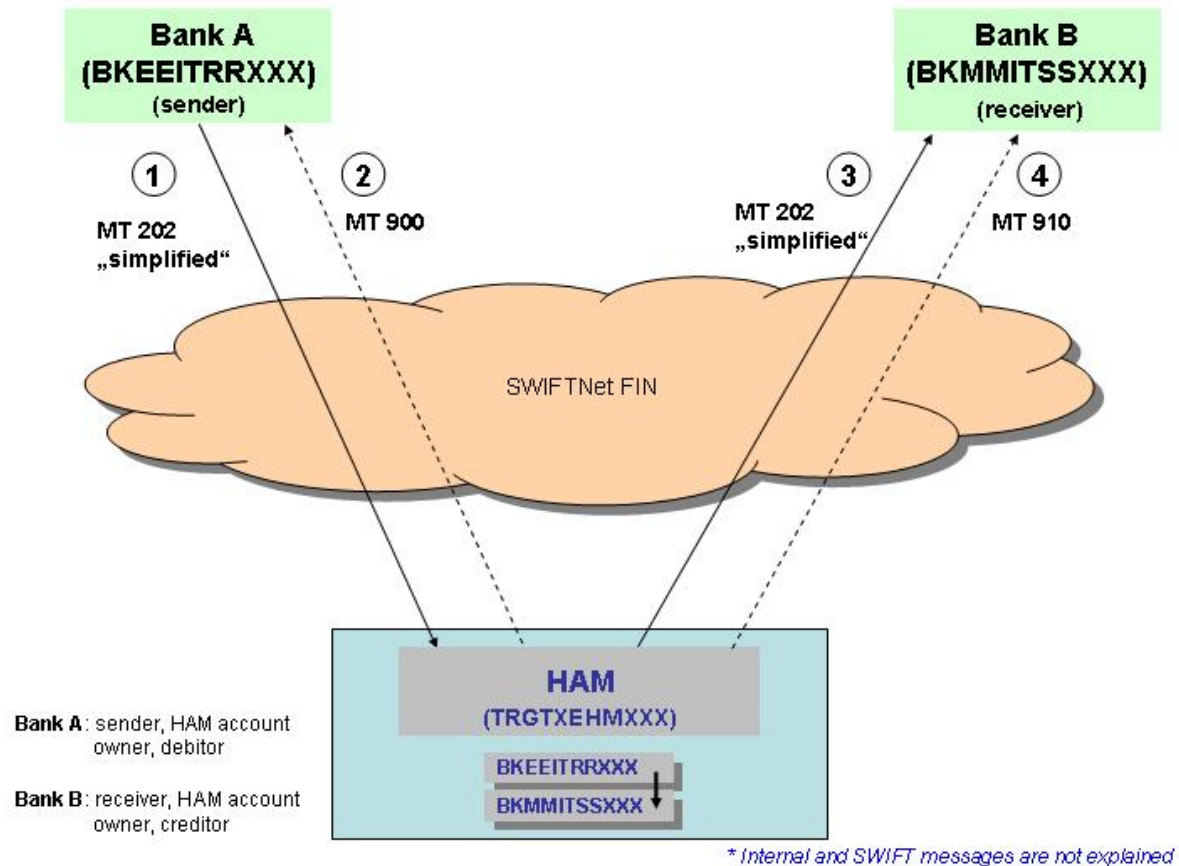

Message	BIC of respective SSP-Module	Field entry
① MT 202 „simplified“ from HAM account holder to HAM	TRGTXEHMXXX (SSP-BIC of HAM)	S: Bank A (BKEEITRRXXX), debtor R: TRGTXEHMXXX 20: TRN (assigned by sender) 21: Related Reference (assigned by sender) 32A: Value date, currency code and amount ... 58a: Bank B (BKMMITSSXXX), creditor, Beneficiary Institution ...

2 Flow of payments/transactions

2.2 Liquidity transfer/Interbank transfer

2.2.1 Liquidity transfer with HAM

Message	BIC of respective SSP-Module	Field entry
<p>② MT 900 (<i>optional</i>) from HAM to sender of initial MT 202</p> <p>(only if the latter has chosen to receive it)</p>	TRGTXEHMXXX (SSP-BIC of HAM)	<p>S: TRGTXEHMXXX R: Bank A (BKEEITRRXXX), sender of initial MT 202 “simplified” ①</p> <hr/> <p>20: TRN by SSP 21: Field 20 of initial MT 202 “simplified” ① 25: Account (which has been debited) Identification 32A: Value date, currency code and amount, field 32A of initial MT 202 “simplified” ① ... 52a: Bank A (BKEEITRRXXX), “Ordering Institution”, sender of initial MT 202 “simplified” ① ... 72: /SETTIME/HHMMSSCC</p>
<p>③ MT 202 “simplified” from HAM to creditor</p>	TRGTXEHMXXX (SSP-BIC of HAM)	<p>S: TRGTXEHMXXX R: Bank B (BKMMITSSXXX), field 58a of initial MT 202 “simplified” ①</p> <hr/> <p>20: TRN (assigned by SSP) 21: Field 21 of initial MT 202 “simplified” 13C: Settlement time 32A: Value date, currency code and amount, field 32A of initial MT 202 “simplified” ① ... 52a: <u>1° line:</u> account to be debited (Bank A = sender of initial MT 202 “simplified”) and TRN of initial MT 202 “simplified” ① <u>2° line:</u> Bank A (BKEEITRRXXX), sender of initial MT 202 “simplified” ① ... 58a: Bank B (BKMMITSSXXX), field 58a of initial MT 202 “simplified” ① ...</p>
<p>④ MT 910 (<i>optional</i>) from HAM to creditor</p>	TRGTXEHMXXX (SSP-BIC of HAM)	<p>S: TRGTXEHMXXX R: Bank B (BKMMITSSXXX), field 58a of initial MT 202 “simplified” ①</p> <hr/> <p>20: TRN by SSP 21: Field 20 ③</p>

2 Flow of payments/transactions

2.2 Liquidity transfer/Interbank transfer

2.2.1 Liquidity transfer with HAM

Message	BIC of respective SSP-Module	Field entry
		25: Account (which has been credited) Identification 32A: Value date, currency code and amount, field 32A of initial MT 202 "simplified" ① ... 52a: Bank A (BKEEITRRXXX), "Ordering Institution", sender of initial MT 202 "simplified" ① ... 72: /SETTIME/HHMMSSCC

2 Flow of payments/transactions

2.2 Liquidity transfer/Interbank transfer

2.2.1 Liquidity transfer with HAM

2.2.1.6.2 Same CB. Order via ICM by co-managed HAM account holder.

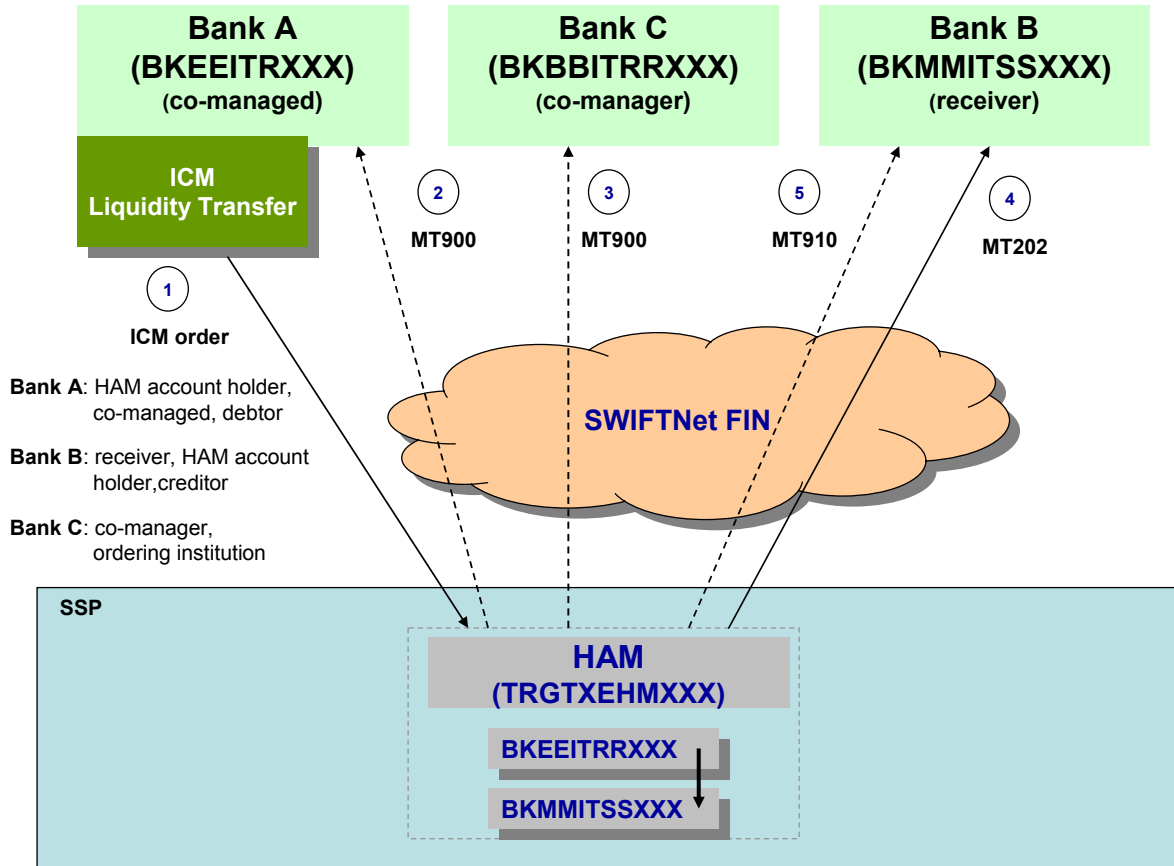

* Internal messages are not explained

Message	BIC of respective SSP-Module	Field entry
① ICM order. Liquidity Transfer (other Accounts)	N/A	S: N/A R: N/A Counterpart for Liquidity Transfer - Participant BIC: Bank B (BKMMITSSXXX), creditor, Beneficiary Institution - Module: HAM - Responsible CB: CB's Country Code of the counterpart (IT) - Liquidity transfer (EUR): amount

2 Flow of payments/transactions

2.2 Liquidity transfer/Interbank transfer

2.2.1 Liquidity transfer with HAM

Message	BIC of respective SSP-Module	Field entry
② MT 900 (optional) from HAM to ordering HAM account holder	TRGTXEHMXXX (SSP-BIC of HAM)	S: TRGTXEHMXXX R: Bank A (BKEEITRRXXX), ordering HAM account holder ①
		20: TRN by SSP 21: NEW 25: Account (which has been debited) Identification 32A: Value date, currency code and amount, ① 52a: Bank A (BKEEITRRXXX), "Ordering Institution", HAM account holder ... 72: /SETTIME/HHMMSSCC
③ MT 900 (optional) from HAM to comanager (only if co-manager has chosen to receive it)	TRGTXEHMXXX (SSP-BIC of HAM)	S: TRGTXEHMXXX R: Bank A (BKBBITRRXXX),
		20: TRN by SSP 21: NEW 25: Account (which has been debited) Identification 32A: Value date, currency code and amount, ① 52a: Bank A (BKEEITRRXXX), "Ordering Institution", HAM account holder ... 72: /SETTIME/HHMMSSCC
④ MT 202 "simplified" from HAM to creditor	TRGTXEHMXXX (SSP-BIC of HAM)	S: TRGTXEHMXXX R: Bank B (BKMMITSSXXX), Counterpart for Liquidity Transfer, Creditor, ①
		20: TRN (assigned by SSP) 21: ICM 13C: Settlement time 32A: Value date, currency code and amount, field 32A of initial ICM order ① ... 52a: <u>1° line</u> : account to be debited

2 Flow of payments/transactions

2.2 Liquidity transfer/Interbank transfer

2.2.1 Liquidity transfer with HAM

Message	BIC of respective SSP-Module	Field entry
		(Bank A = HAM Account holder) ① <u>2° line:</u> Bank A (BKEEITRRXXX), Ordering HAM account holder ① 58a: Bank B (BKMMITSSXXX), Counterpart for Liquidity Transfer ① ...
⑤ MT 910 (optional) from HAM to creditor	TRGTXEHMXXX (SSP-BIC of HAM)	S: TRGTXEHMXXX R: Bank B (BKMMITSSXXX), Counterpart for Liquidity Transfer ① 20: TRN by SSP 21: Related reference by SSP 25: Account (which has been credited) Identification 32A: Value date, currency code and amount ① 52a: Bank A (BKEEITRRXXX), "Ordering Institution", HAM account holder ① ... 72: /SETTIME/HHMMSSCC

2.2.1.6.3 Different CB

Not allowed.

2 Flow of payments/transactions

2.2 Liquidity transfer/Interbank transfer

2.2.1 Liquidity transfer with HAM

2.2.1.7 Liquidity transfer between "HAM accounts" initiated by a co-manager

2.2.1.7.1 Same CB, via SWIFT FIN payment.

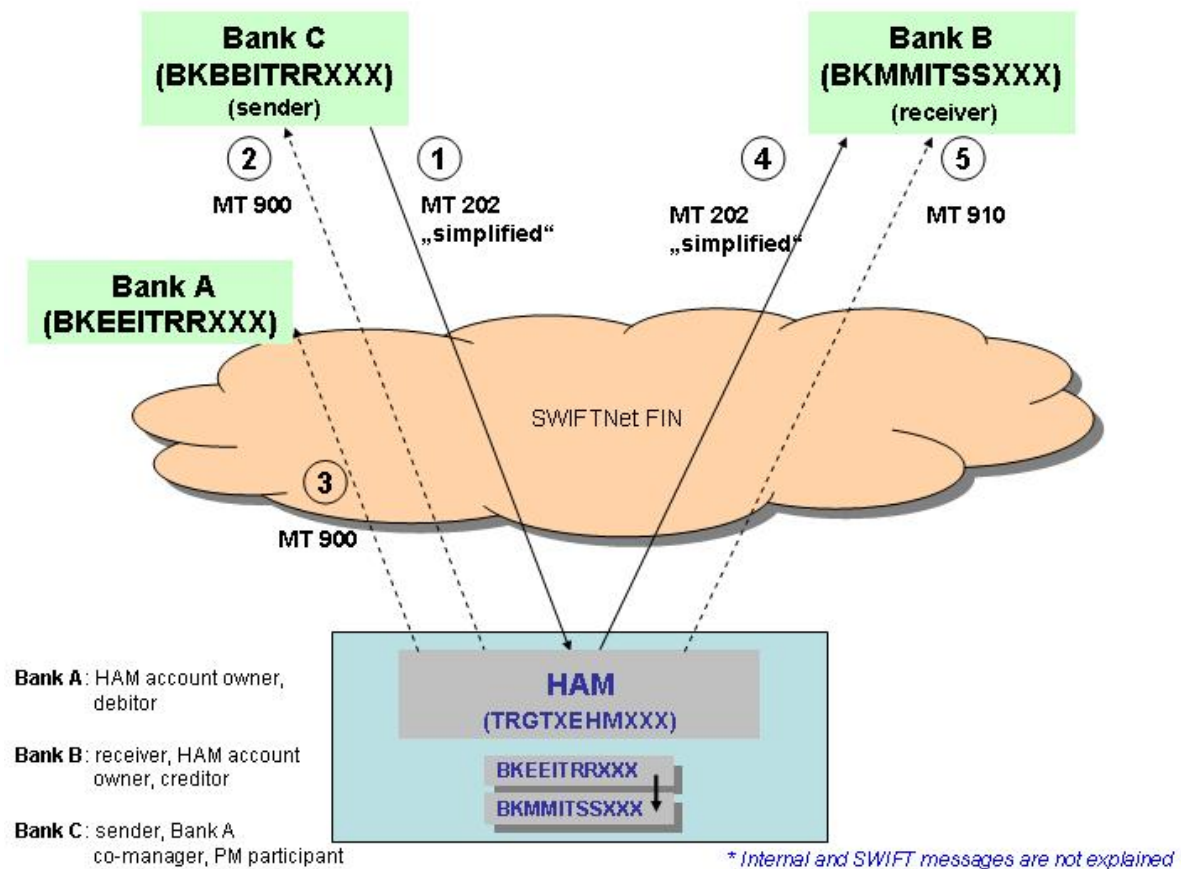

Message	BIC of respective SSP-Module	Field entry
① MT 202 "simplified" from co-manager to HAM	TRGTXEHMXXX (SSP-BIC of HAM)	S: Bank C (BKBBITRRXXX) - Co-manager (PM participant)
		R: TRGTXEHMXXX
		20: TRN (assigned by sender)
		21: Related Reference (assigned by sender)

2 Flow of payments/transactions

2.2 Liquidity transfer/Interbank transfer

2.2.1 Liquidity transfer with HAM

Message	BIC of respective SSP-Module	Field entry
		32A: Value date, currency code and amount ... 53a: Bank A (BKEEITRRXXX), debtor, co-managed participant ... 58a: Bank B (BKMMITSSXXX), creditor, Beneficiary Institution
② MT 900 (optional) from HAM to co-manager (only if co-manager has chosen to receive it)	TRGTXEHMXXX (SSP-BIC of HAM)	S: TRGTXEHMXXX R: Bank C (BKBBITRRXXX) - Co-manager (PM participant), sender of initial MT 202 "simplified" ① 20: TRN by SSP 21: Field 20 of initial MT 202 "simplified" ① 25: Account (which has been debited) Identification 32A: Value date, currency code and amount, field 32A of initial MT 202 "simplified" ① ... 52a: Bank C (BKBBITRRXXX) - Co-manager (PM participant), sender of initial MT 202 "simplified" ① ... 72: /SETTIME/HHMMSSCC
③ MT 900 (optional) from HAM to co-managed account	TRGTXEHMXXX (SSP-BIC of HAM)	S: TRGTXEHMXXX R: Bank A (BKEEITRRXXX), debtor, field 53a of initial MT 202 "simplified" 20: TRN by SSP 21: NEW 25: Account (which has been debited) Identification 32A: Value date, currency code and amount, field 32A of initial MT 202 "simplified" ① ... 52a: Bank C (BKBBITRRXXX) - Co-manager (PM participant), sender of initial MT 202 "simplified" ① ... 72: /SETTIME/HHMMSSCC
④ MT 202 "simplified" from HAM to creditor	TRGTXEHMXXX (SSP-BIC of HAM)	S: TRGTXEHMXXX R: Bank B (BKMMITSSXXX), creditor, field 58a of initial MT 202 "simplified" 20: TRN (assigned by SSP) 21: Field 21 of initial MT 202 "simplified" ① 13C: Settlement time 32A: Value date, currency code and amount, field 32A of initial MT 202 "simplified" ①

2 Flow of payments/transactions

2.2 Liquidity transfer/Interbank transfer

2.2.1 Liquidity transfer with HAM

Message	BIC of respective SSP-Module	Field entry
		<p>...</p> <p>52a: <u>1° line:</u> Account to be debited (co managed) and TRN of initial MT 202 “simplified” ①</p> <p><u>2° line:</u> Bank C (BKBBITRRXXX) - Co-manager (PM participant), sender of initial MT 202 “simplified” ①</p> <p>53a: Bank A (BKEEITRRXXX), debtor, field 53a of initial MT 202 “simplified” ①</p> <p>...</p> <p>58a: Bank B (BKMMITSSXXX), creditor, field 58a of initial MT 202 “simplified” ①</p> <p>...</p>
⑤ MT 910 (optional) from HAM to creditor	TRGTXEHMXXX (SSP-BIC of HAM)	<p>S: TRGTXEHMXXX</p> <p>R: Bank B (BKMMITSSXXX), creditor, field 58a of initial MT 202 “simplified” ①</p> <hr/> <p>20: TRN by SSP</p> <p>21: Field 20 (TRN) ④</p> <p>25: Account (which has been credited) Identification</p> <p>32A: Value date, currency code and amount, field 32A of initial MT 202 “simplified” ①</p> <p>...</p> <p>52a: Bank C (BKBBITRRXXX) - Co-manager, PM participant, “Ordering Institution”, sender of initial MT 202 “simplified” ①</p> <p>...</p> <p>56a: Bank A (BKEEITRRXXX), debtor, field 53a of initial MT 202 “simplified” ①</p> <p>...</p> <p>72: /SETTIME/HHMMSSCC</p>

2.2.1.7.2 Different CB

Not allowed.

2 Flow of payments/transactions

2.2 Liquidity transfer/Interbank transfer

2.2.1 Liquidity transfer with HAM

2.2.1.7.3 Same CB. Order via ICM by co-manager.

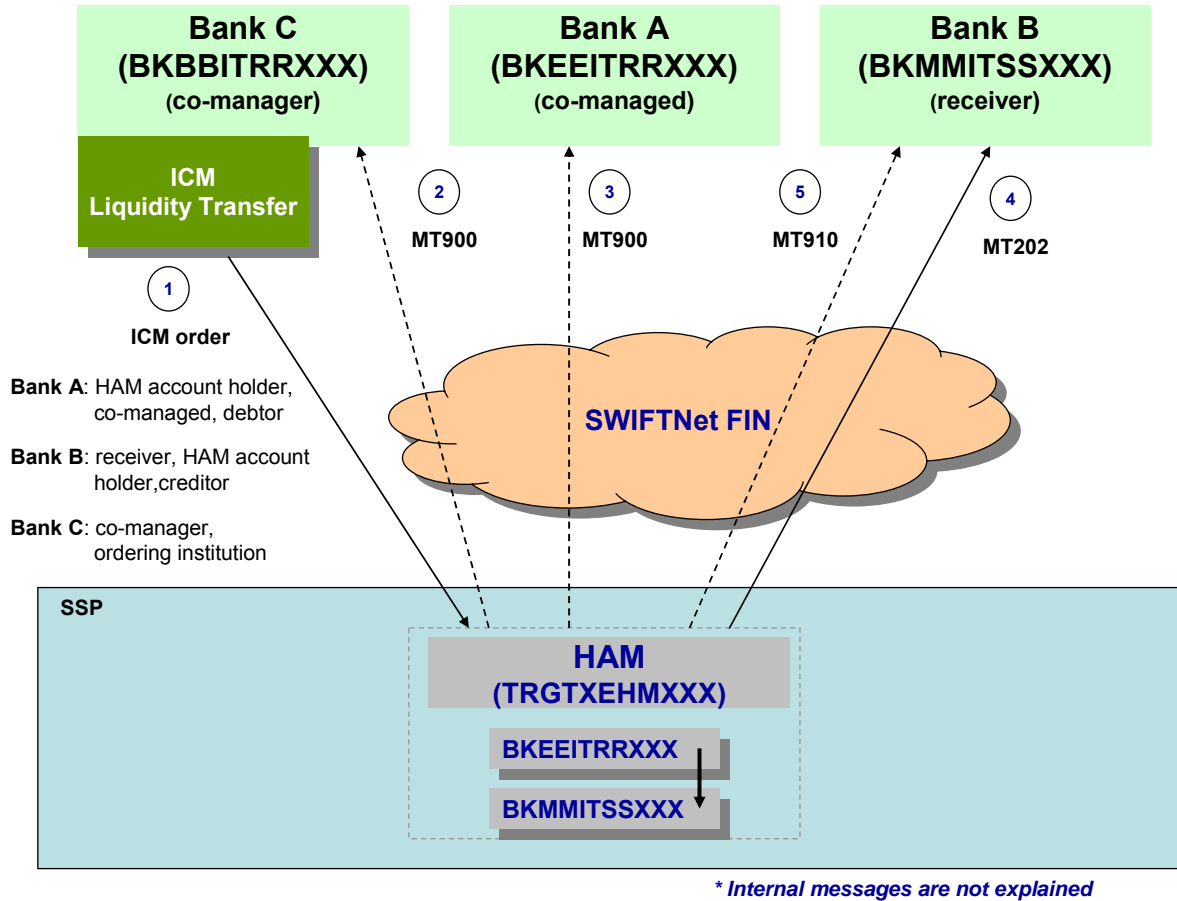

Message	BIC of respective SSP-Module	Field entry
① ICM internal message ordered by co-manager	N/A	S: N/A R: N/A Participant BIC: HAM account holder Bank A (BKEEITRRXXX) Counterpart for Liquidity Transfer - Participant BIC: Bank B (BKMMITSSXXX), creditor, Beneficiary Institution - Module: HAM - Responsible CB: CB's Country Code of the

2 Flow of payments/transactions

2.2 Liquidity transfer/Interbank transfer

2.2.1 Liquidity transfer with HAM

Message	BIC of respective SSP-Module	Field entry
		counterpart (IT) - Liquidity transfer (EUR): amount
② MT 900 (optional) from HAM to co-manager (only if co-manager has chosen to receive it)	TRGTXEHMXXX (SSP-BIC of HAM)	S: TRGTXEHMXXX R: Bank C (BKBBITRRXXX) - Co-manager, ordering institution via ICM 20: TRN by SSP 21: NEW 25: Account (which has been debited) Identification 32A: Value date, currency code and amount, ① 52a: Bank C (BKBBITRRXXX) - Co-manager, ordering institution via ICM ... 72: /SETTIME/HHMMSSCC
③ MT 900 (optional) from HAM to co-managed account (only if the co- managed has chosen to receive it)	TRGTXEHMXXX (SSP-BIC of HAM)	S: TRGTXEHMXXX R: Bank A (BKEEITRRXXX), debtor, Participant BIC, HAM account holder 20: TRN by SSP 21: NEW 25: Account (which has been debited) Identification 32A: Value date, currency code and amount, ... 52a: Bank C (BKBBITRRXXX) - Co-manager, ordering institution via ICM ... 72: /SETTIME/HHMMSSCC
④ MT 202 "simplified" from HAM to creditor	TRGTXEHMXXX (SSP-BIC of HAM)	S: TRGTXEHMXXX R: Bank B (BKMMITSSXXX), creditor, Counterpart for Liquidity Transfer 20: TRN (assigned by SSP) 21: ICM 13C: Settlement time 32A: Value date, currency code and amount, field 32A of initial MT 202 "simplified" ① ... 52a: <u>1° line:</u> Account to be debited (co managed) and SSP reference ① <u>2° line:</u> Bank C (BKBBITRRXXX) - Co-manager Ordering institution via ICM ①

2 Flow of payments/transactions

2.2 Liquidity transfer/Interbank transfer

2.2.1 Liquidity transfer with HAM

Message	BIC of respective SSP-Module	Field entry
		53a: Bank A (BKEEITRRXXX), debtor, co-managed HAM account holder ① ... 58a: Bank B (BKMMITSSXXX), creditor, Counterpart for Liquidity Transfer ① ...
⑤ MT 910 (optional) from HAM to creditor (only if the creditor has chosen to receive it)	TRGTXEHMXXX (SSP-BIC of HAM)	S: TRGTXEHMXXX R: Bank B (BKMMITSSXXX), creditor, Counterpart for Liquidity Transfer ① 20: TRN by SSP 21: Field 20 (TRN) ④ 25: Account (which has been credited) Identification 32A: Value date, currency code and amount, ... 52a: Bank C (BKBBITRRXXX) - Co-manager, Co-manager, ordering institution via ICM ① ... 56a: Bank A (BKEEITRRXXX), debtor, co-managed HAM account holder ① ... 72: /SETTIME/HHMMSSCC

2 Flow of payments/transactions

2.2 Liquidity transfer/Interbank transfer

2.2.1 Liquidity transfer with HAM

2.2.1.8 Interbank transfer from "HAM account" to RTGS account of a direct participant initiated by a co-manager

2.2.1.8.1 Same CB, via SWIFT FIN payment

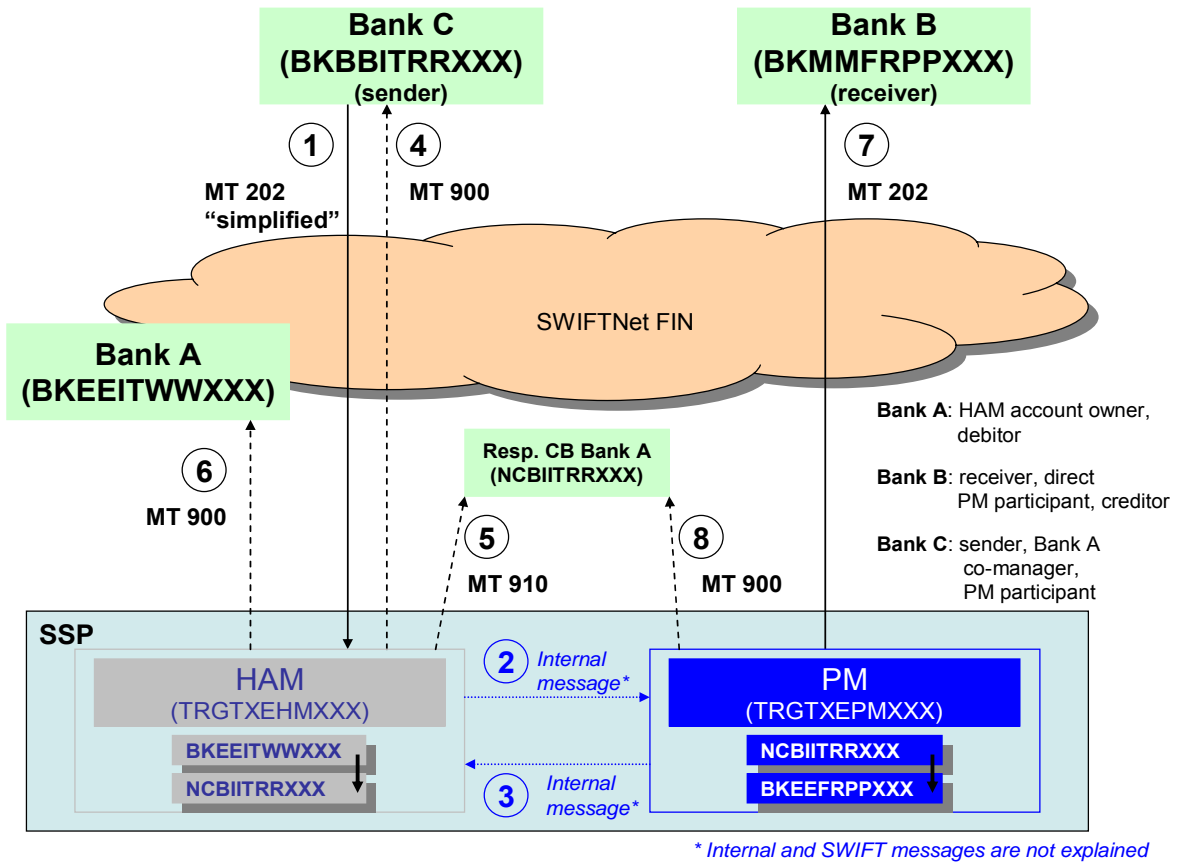

Message	BIC of respective SSP-Module	Field entry
① MT 202 „simplified“ from co-manager to HAM	TRGTXEHMXXX (SSP-BIC of HAM)	S: Bank C (BKBBITRRXXX) - Co-manager (PM participant) R: TRGTXEHMXXX
		20: TRN (assigned by sender) 21: Related Reference (assigned by sender) 32A: Value date, currency code and amount 53a: Bank A (BKEEITWWXXX), debtor, co-managed,

2 Flow of payments/transactions

2.2 Liquidity transfer/Interbank transfer

2.2.1 Liquidity transfer with HAM

Message	BIC of respective SSP-Module	Field entry
		<p>HAM participant</p> <p>...</p> <p>57a: Debtor's CB (NCBIITRRXXX)</p> <p>58a: Bank B (BKMMFRPPXXX), PM participant, creditor, Beneficiary Institution</p>
④ MT 900 (optional) from HAM to co-manager	TRGTXEHMXXX (SSP-BIC of HAM)	<p>S: TRGTXEHMXXX</p> <p>R: Bank C (BKBBITRRXXX) - Co-manager (PM participant), sender of initial MT 202 "simplified" ①</p>
		<p>20: TRN by SSP</p> <p>21: Field 20 (TRN) of initial MT 202 "simplified" ①</p> <p>25: Account (which has been debited) Identification</p> <p>32A: Value date, currency code and amount, field 32A of initial MT 202 "simplified" ①</p> <p>...</p> <p>52a: Bank C (BKBBITRRXXX) - Co-manager, PM participant, "Ordering Institution", sender of initial MT 202 "simplified" ①</p> <p>...</p> <p>72: /SETTIME/HHMMSSCC</p>
⑤ MT 910 (optional) from HAM to the CB of the debtor (co-managed participant)	TRGTXEHMXXX (SSP-BIC of HAM)	<p>S: TRGTXEHMXXX</p> <p>R: (NCBIITRRXXX), CB of the debtor (co-managed participant) of initial MT 202 "simplified" ①</p>
		<p>20: TRN by SSP</p> <p>21: NEW</p> <p>25: Account (which has been credited) Identification</p> <p>32A: Value date, currency code and amount</p> <p>...</p> <p>52a: Bank C (BKBBITRRXXX) - Co-manager (PM participant), "Ordering Institution", sender of initial MT 202 "simplified" (co-managed participant) ①</p> <p>...</p> <p>56a: Bank A (BKEEITWWXXX), debtor, field 53a of initial MT 202 "simplified" ①</p> <p>...</p> <p>72: /SETTIME/HHMMSSCC /INTERMOD/</p>
⑥ MT 900 (optional) from HAM to co-managed	TRGTXEHMXXX (SSP-BIC of HAM)	<p>S: TRGTXEHMXXX</p> <p>R: Co-managed account (BKEEITWWXXX), field 53a of initial MT 202 "simplified" ①</p>

2 Flow of payments/transactions

2.2 Liquidity transfer/Interbank transfer

2.2.1 Liquidity transfer with HAM

Message	BIC of respective SSP-Module	Field entry
		20: TRN by SSP 21: NEW 25: Account (which has been debited) Identification 32A: Value date, currency code and amount, field 32A of initial MT 202 "simplified" ① ... 52a: Bank C (BKBBITRRXXX) - Co-manager (PM participant), "Ordering Institution", sender of initial MT 202 "simplified" ① ... 72: /SETTIME/HHMMSSCC
⑦ MT 202 from PM to creditor	TRGTXEPMXXX (SSP-BIC of PM)	S: TRGTXEPMXXX R: Bank B (BKMMFRPPXXX) - PM participant, field 58a of initial MT 202 "simplified" ①
		20: TRN by SSP 21: Field 21 of initial MT 202 "simplified" ① 32A: Value date, currency code and amount, field 32A of initial MT 202 "simplified" ① ... 52a: Bank A (BKEEITWWXXX), debtor, co-managed, HAM participant 53a: Debtor's CB (NCBIITRRXXX), "sender's correspondent", field 57a of initial MT 202 "simplified" ① ... 58a: Bank B (BKMMFRPPXXX) - PM participant, field 58a of initial MT 202 "simplified" ① ...
⑧ MT 900 (optional) from PM to the CB of the debtor (co-managed participant)	TRGTXEPMXXX (SSP-BIC of PM)	S: TRGTXEPMXXX R: NCBIITRRXXX, CB of the debtor (co-managed participant) of initial MT 202 "simplified" ①
		20: TRN by SSP = field 20 ⑤ 21: Field 20 25: Account (which has been debited) Identification 32A: Value date, currency code and amount ... 52a: Debtor's CB ...

2 Flow of payments/transactions

2.2 Liquidity transfer/Interbank transfer

2.2.1 Liquidity transfer with HAM

2.2.1.8.2 Different CB, via SWIFT FIN payment

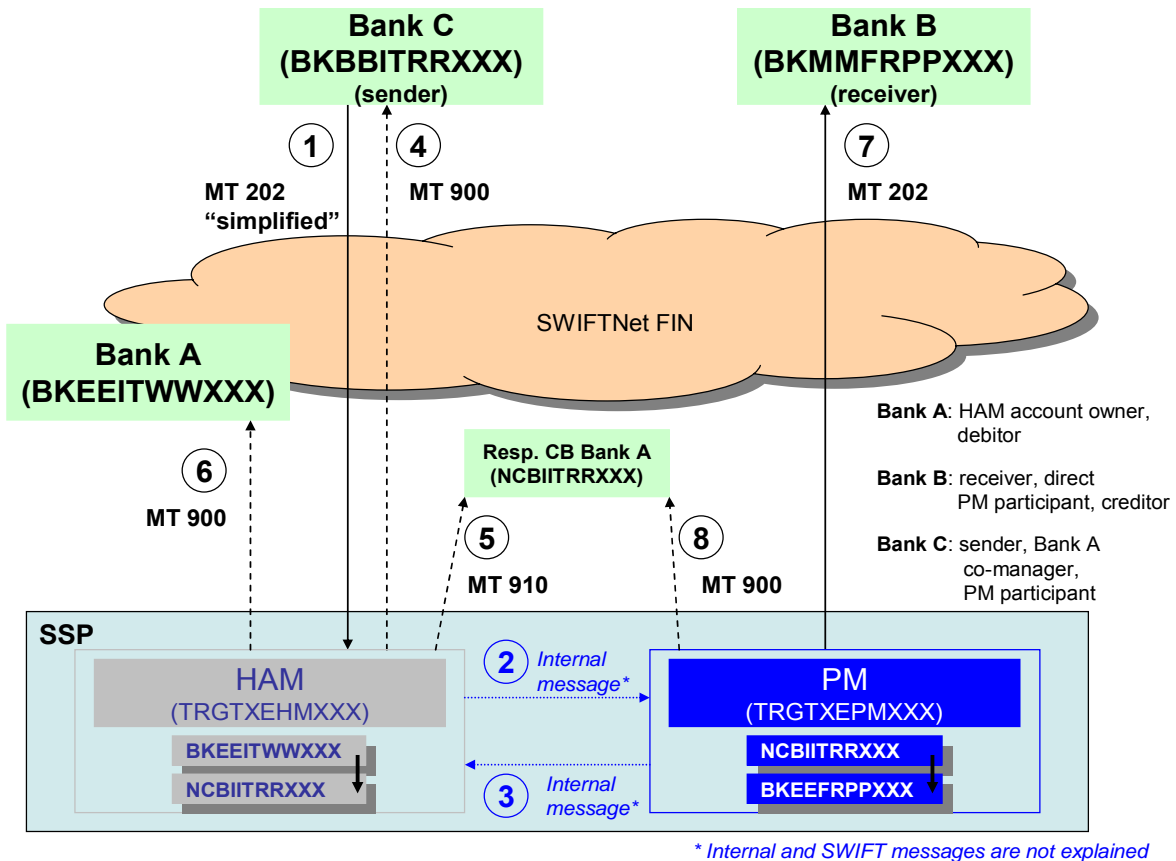

Message	BIC of respective SSP-Module	Field entry
① MT 202 „simplified“ from co-manager to HAM	TRGTXEHMXXX (SSP-BIC of HAM)	S: Bank C (BKBBITRRXXX) - Co-manager (PM participant) R: TRGTXEHMXXX
		20: TRN (assigned by sender) 21: Related Reference (assigned by sender) 32A: Value date, currency code and amount 53a: Bank A (BKEEITWWXXX), debtor, co-managed, HAM participant ...

2 Flow of payments/transactions

2.2 Liquidity transfer/Interbank transfer

2.2.1 Liquidity transfer with HAM

Message	BIC of respective SSP-Module	Field entry
		57a: Debtor's CB (NCBIITRRXXX) 58a: Bank B (BKMMFRPPXXX), PM participant, creditor, Beneficiary Institution
④ MT 900 (optional) from HAM to co-manager	TRGTXEHMXXX (SSP-BIC of HAM)	S: TRGTXEHMXXX R: Bank C (BKBBITRRXXX) - Co-manager (PM participant), sender of initial MT 202 "simplified" ① 20: TRN by SSP 21: Field 20 (TRN) of initial MT 202 "simplified" ① 25: Account (which has been debited) Identification 32A: Value date, currency code and amount, field 32A of initial MT 202 "simplified" ① ... 52a: Bank C (BKBBITRRXXX) - Co-manager, PM participant, "Ordering Institution", sender of initial MT 202 "simplified" ① ... 72: /SETTIME/HHMMSSCC
⑤ MT 910 (optional) from HAM to the CB of the debtor (co-managed participant)	TRGTXEHMXXX (SSP-BIC of HAM)	S: TRGTXEHMXXX R: (NCBIITRRXXX), CB of the debtor (co-managed participant) of initial MT 202 "simplified" ① 20: TRN by SSP 21: NEW 25: Account (which has been credited) Identification 32A: Value date, currency code and amount ... 52a: Bank C (BKBBITRRXXX) - Co-manager (PM participant), "Ordering Institution", sender of initial MT 202 "simplified" (co-managed participant) ① ... 56a: Bank A (BKEEITWWXXX), debtor, field 53a of initial MT 202 "simplified" ① ... 72: /SETTIME/HHMMSSCC /INTERMOD/
⑥ MT 900 (optional) from HAM to co-managed	TRGTXEHMXXX (SSP-BIC of HAM)	S: TRGTXEHMXXX R: Co-managed account (BKEEITWWXXX), field 53a of initial MT 202 "simplified" ① 20: TRN by SSP 21: NEW

2 Flow of payments/transactions

2.2 Liquidity transfer/Interbank transfer

2.2.1 Liquidity transfer with HAM

Message	BIC of respective SSP-Module	Field entry
		25: Account (which has been debited) Identification 32A: Value date, currency code and amount, field 32A of initial MT 202 "simplified" ① ... 52a: Bank C (BKBBITRRXXX) - Co-manager (PM participant), "Ordering Institution", sender of initial MT 202 "simplified" ① ... 72: /SETTIME/HHMMSSCC
⑦ MT 202 from PM to creditor	TRGTXEPMXXX (SSP-BIC of PM)	S: TRGTXEPMXXX R: Bank B (BKMMFRPPXXX) - PM participant, field 58a of initial MT 202 "simplified" ① ... 20: TRN by SSP 21: Field 21 of initial MT 202 "simplified" ① 32A: Value date, currency code and amount, field 32A of initial MT 202 "simplified" ① ... 52a: Bank A (BKEEITWWXXX), debtor, co-managed, HAM participant 53a: Debtor's CB (NCBIITRRXXX), "sender's correspondent", field 57a of initial MT 202 "simplified" ① ... 58a: Bank B (BKMMFRPPXXX) - PM participant, field 58a of initial MT 202 "simplified" ① ...
⑧ MT 900 (optional) from PM to the CB of the debtor (co-managed participant)	TRGTXEPMXXX (SSP-BIC of PM)	S: TRGTXEPMXXX R: NCBIITRRXXX, CB of the debtor (co-managed participant) of initial MT 202 "simplified" ① ... 20: TRN by SSP = field 20 ⑤ 21: Field 20 25: Account (which has been debited) Identification 32A: Value date, currency code and amount ... 52a: Debtor's CB ...

2 Flow of payments/transactions

2.2 Liquidity transfer/Interbank transfer

2.2.1 Liquidity transfer with HAM

2.2.1.9 Interbank transfer from "HAM account" to the RTGS account of the co-manager initiated by the co-manager

2.2.1.9.1 Same CB, via SWIFT FIN payment

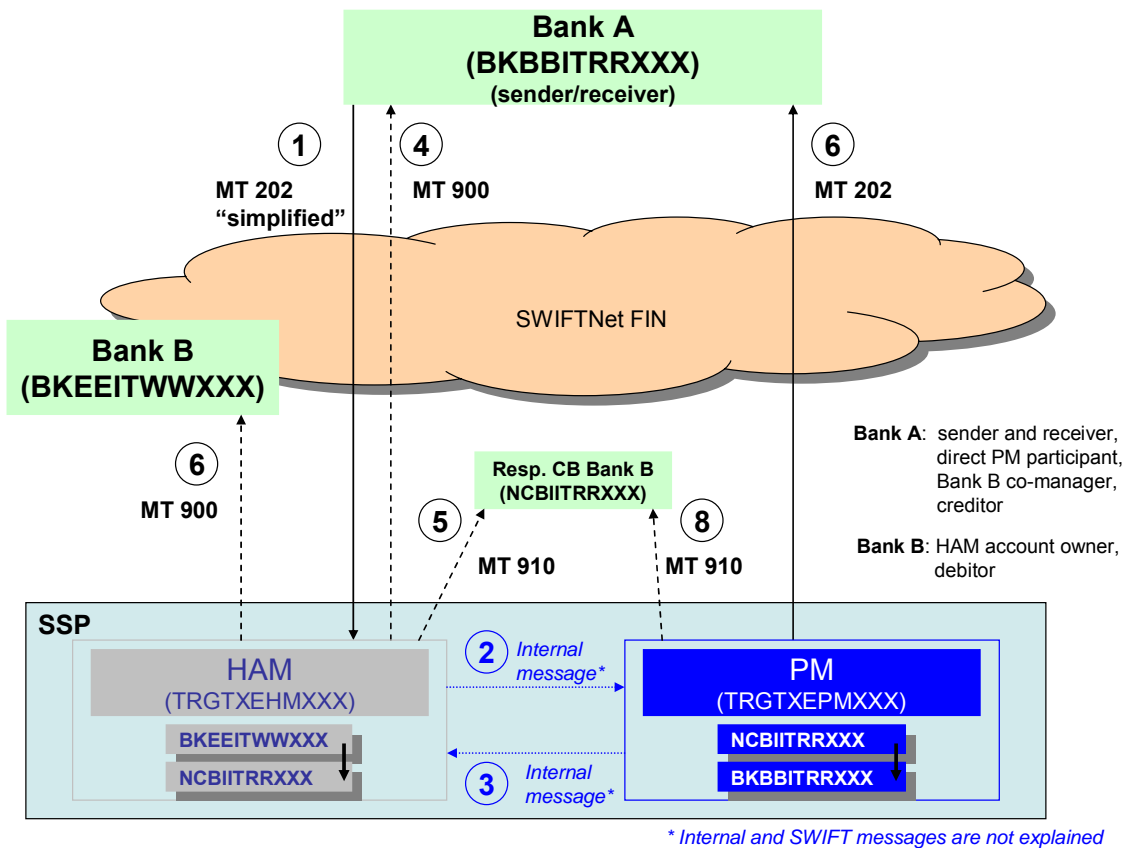

Message	BIC of respective SSP module	Field entry
① MT 202 „simplified“ from co-manager to HAM	TRGTXEHMXXX (SSP-BIC of HAM)	S: Bank A (BKBBITRRXXX) - Co-manager, PM participant R: TRGTXEHMXXX
		20: TRN (assigned by sender)

2 Flow of payments/transactions

2.2 Liquidity transfer/Interbank transfer

2.2.1 Liquidity transfer with HAM

Message	BIC of respective SSP module	Field entry
		21: Related Reference (assigned by sender) 32A: Value date, currency code and amount ... 53a: Co-managed account (BKEEITWWXXX), debtor, HAM participant ... 57a: Debtor`s/creditor`s CB (NCBIITRRXXX) 58a: Bank A (BKBBITRRXXX) – Co-manager, PM participant, Beneficiary Institution, sender of initial MT 202 “simplified” ① ...
④ MT 900 (optional) from HAM to co-manager (only if the co-manager has chosen to receive it)	TRGTXEHMXXX (SSP-BIC of HAM)	S: TRGTXEHMXXX R: Bank A (BKBBITRRXXX), sender of initial MT 202 “simplified” ① 20: TRN by SSP 21: Field 20 (TRN) of initial MT 202 “simplified” ① 25: Account (which has been debited) Identification 32A: Value date, currency code and amount, field 32A of initial MT 202 “simplified” ① ... 52a: Bank A (BKBBITRRXXX) - Co-manager, PM participant, “Ordering Institution”, sender of initial MT 202 “simplified” ① ... 72: /SETTIME/HHMMSSCC
⑤ MT 910 (optional) from HAM to the debtor/creditor`s CB	TRGTXEHMXXX (SSP-BIC of HAM)	S: TRGTXEHMXXX R: (NCBIITRRXXX), debtor/creditor`s CB 20: TRN by SSP 21: NEW 25: Account (which has been credited) Identification 32A: Value date, currency code and amount ... 52a: Bank A (BKBBITRRXXX) - Co-manager (PM participant), “Ordering Institution”, sender of initial MT 202 “simplified” (co-managed participant) ① ... 56a: Bank B (BKEEITWWXXX), debtor, field 53a of initial MT 202 “simplified” ① ... 72: /SETTIME/HHMMSSCC /INTERMOD/

2 Flow of payments/transactions

2.2 Liquidity transfer/Interbank transfer

2.2.1 Liquidity transfer with HAM

Message	BIC of respective SSP module	Field entry
⑥ MT 900 (optional) from HAM to co-managed account	TRGTXEHMXXX (SSP-BIC of HAM)	S: TRGTXEHMXXX R: Co-managed account (BKEEITWWXXX), debtor, HAM participant, field 53a of initial MT 202 "simplified" ①
		20: TRN by SSP 21: NEW 25: Account (which has been debited) Identification 32A: Value date, currency code and amount, field 32A of initial MT 202 "simplified" ① ... 52a: Bank A (BKBBITRRXXX) - Co-manager, PM participant, "Ordering Institution", sender of initial MT 202 "simplified" ① ... 72: /SETTIME/HHMMSSCC
⑦ MT 202 from PM to creditor	TRGTXEPMXXX (SSP-BIC of PM)	S: TRGTXEPMXXX R: Bank A (BKBBITRRXXX) - Co-manager, PM participant, field 58a of initial MT 202 "simplified" (= sender) ①
		20: TRN by SSP 21: Field 21 of initial MT 202 "simplified" ① 32A: Value date, currency code and amount, field 32A of initial MT 202 "simplified" ① ... 52a: Bank B (BKEEITWWXXX), debtor, co-managed, HAM participant 53a: Debtor's/creditor's CB (NCBIITRRXXX), "sender's correspondent", field 57a of initial MT 202 "simplified" ① ... 58a: Bank A (BKBBITRRXXX) - Co-manager, PM participant, field 58a of initial MT 202 "simplified" (= sender) ①
⑧ MT 900 (optional) from PM to the debtor/creditor's CB	TRGTXEPMXXX (SSP-BIC of PM)	S: TRGTXEPMXXX R: NCBIITRRXXX, debtor/creditor's CB
		20: TRN by SSP = field 20 ⑤ 21: Field 20 25: Account (which has been debited) Identification 32A: Value date, currency code and amount ...

2 Flow of payments/transactions

2.2 Liquidity transfer/Interbank transfer

2.2.1 Liquidity transfer with HAM

Message	BIC of respective SSP module	Field entry
		52a: Debtor's CB

2 Flow of payments/transactions

2.2 Liquidity transfer/Interbank transfer

2.2.1 Liquidity transfer with HAM

2.2.1.9.2 Different CB, via SWIFT FIN payment

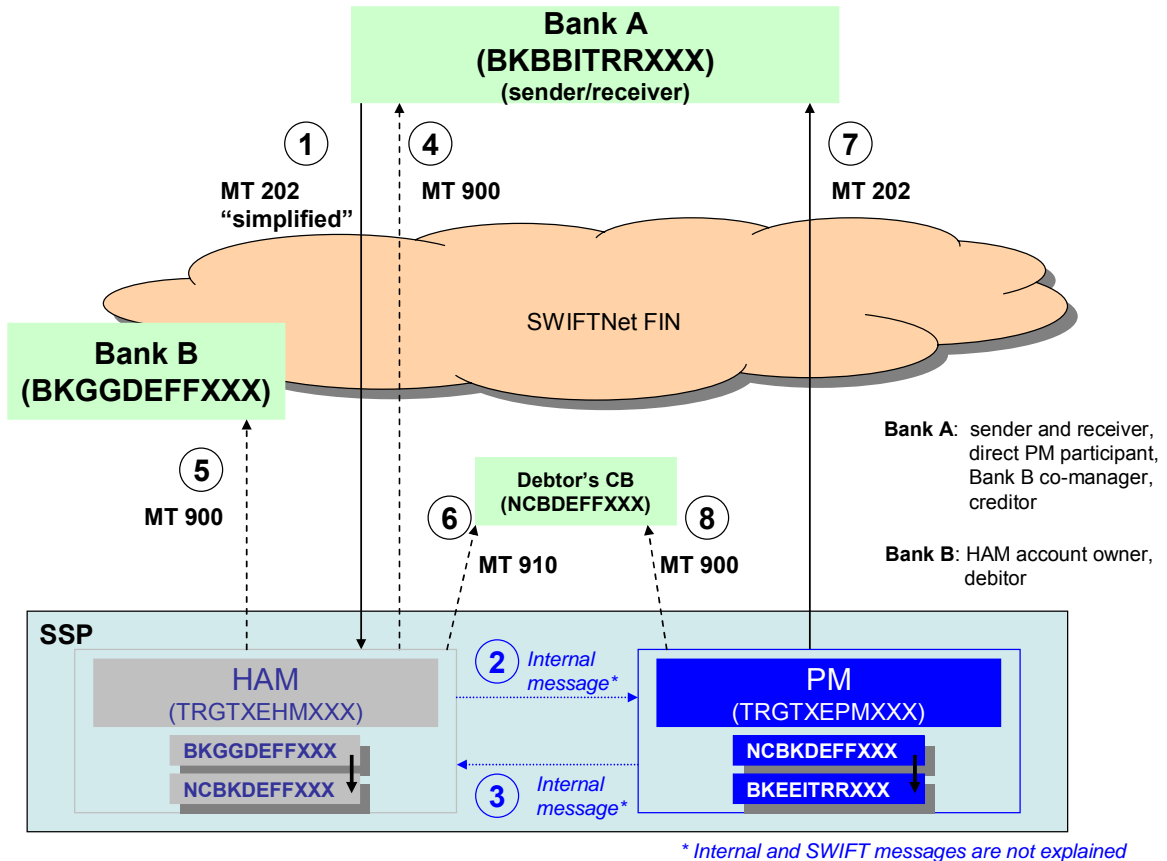

Message	BIC of respective SSP module	Field entry
① MT 202 „simplified“ from co-manager to HAM	TRGTXEHMXXX (SSP-BIC of HAM)	S: Bank A (BKBBITRRXXX) - Co-manager, PM participant R: TRGTXEHMXXX 20: TRN (assigned by sender) 21: Related Reference (assigned by sender) 32A: Value date, currency code and amount ... 53a: Co-managed account (BKGGDEFFXXX), debtor, HAM participant ... 57a: Debtor's CB (NCBKDEFFXXX)

2 Flow of payments/transactions

2.2 Liquidity transfer/Interbank transfer

2.2.1 Liquidity transfer with HAM

Message	BIC of respective SSP module	Field entry
		58a: Bank A (BKBBITRRXXX) - Co-manager, PM participant, Beneficiary Institution, sender of initial MT 202 "simplified" ① ...
④ MT 900 (optional) from HAM to co-manager	TRGTXEHMXXX (SSP-BIC of HAM)	S: TRGTXEHMXXX R: Bank A (BKBBITRRXXX) - Co-manager, PM participant, sender of initial MT 202 "simplified" ①
		20: TRN by SSP 21: Field 20 (TRN) of initial MT 202 "simplified" ① 25: Account (which has been debited) Identification 32A: Value date, currency code and amount, field 32A of initial MT 202 "simplified" ① 52a: Debtor's CB (NCBKDEFFXXX) ... 72: /SETTIME/HHMMSSCC
⑤ MT 900 (optional) from HAM to co-managed account	TRGTXEHMXXX (SSP-BIC of HAM)	S: TRGTXEHMXXX R: Co-managed account (BKGGDEFFXXX), debtor, HAM participant, field 53a of initial MT 202 "simplified" ①
		20: TRN by SSP 21: NEW 25: Account (which has been debited) Identification 32A: Value date, currency code and amount, field 32A of initial MT 202 "simplified" ① ... 52a: Debtor's CB (NCBKDEFFXXX) ... 72: /SETTIME/HHMMSSCC
⑥ MT 910 (optional) from HAM to the debtor's CB	TRGTXEHMXXX (SSP-BIC of HAM)	S: TRGTXEHMXXX R: (NCBKDEFFXXX), debtor's CB
		20: TRN by SSP 21: NEW 25: Account (which has been credited) Identification 32A: Value date, currency code and amount 52a: Bank A (BKBBITRRXXX) - Co-manager (PM

2 Flow of payments/transactions

2.2 Liquidity transfer/Interbank transfer

2.2.1 Liquidity transfer with HAM

Message	BIC of respective SSP module	Field entry
		participant), "Ordering Institution", sender of initial MT 202 "simplified" (co-managed participant) ① ... 56a: Bank B (BKGDEFFXXX), debtor, field 53a of initial MT 202 "simplified" ① ... 72: /SETTIME/HHMMSSCC /INTERMOD/
⑦ MT 202 from PM to creditor	TRGTXEPMXXX (SSP-BIC of PM)	S: TRGTXEPMXXX R: Bank A (BKBBITRRXXX) - Co-manager, PM participant, field 58a of initial MT 202 "simplified" (= sender) ① ... 20: TRN 21: Field 21 of initial MT 202 "simplified" ① 32A: Value date, currency code and amount, field 32A of initial MT 202 "simplified" ① ... 52a: Bank B (BKGDEFFXXX), debtor, co managed, HAM participant 53a: Debtor's CB (NCBKDEFFXXX) ... 58a: Bank A (BKBBITRRXXX) - Co-manager, PM participant, field 58a of initial MT 202 "simplified" (= sender) ① ...
⑧ MT 900 (optional) from PM to the debtor's CB	TRGTXEPMXXX (SSP-BIC of PM)	S: TRGTXEPMXXX R: (NCBKDEFFXXX), debtor's CB ... 20: TRN by SSP = field 20 ⑤ 21: Field 20 25: Account (which has been debited) Identification 32A: Value date, currency code and amount, field 32A of initial MT 202 "simplified" ① ... 52a: Debtor's CB (NCBKDEFFXXX), ...

2 Flow of payments/transactions

2.2 Liquidity transfer/Interbank transfer

2.2.1 Liquidity transfer with HAM

2.2.1.10 Interbank transfer from “HAM account” to the RTGS account of the co-manager initiated by the co-managed. Same CB.

2.2.1.10.1 Same CB via SWIFT FIN payment

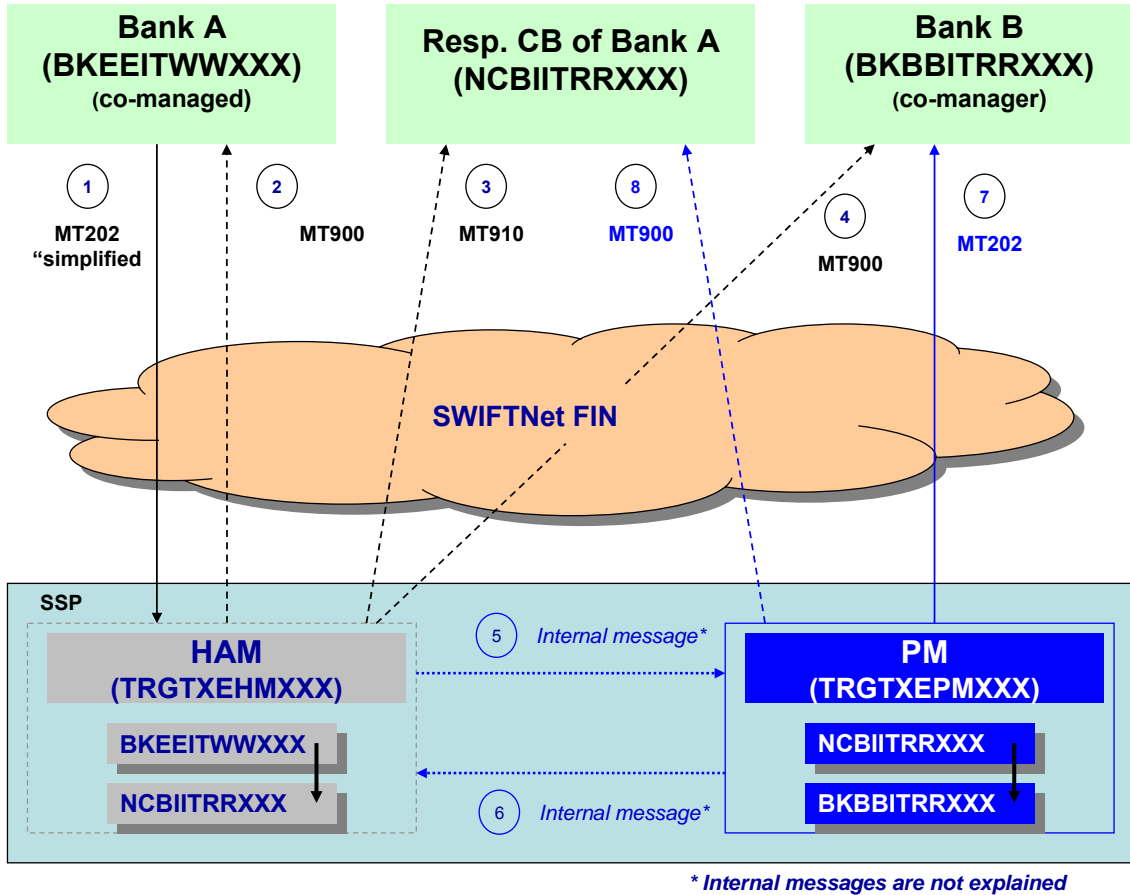

Message	BIC of respective SSP module	Field entry
① MT 202 „simplified“ from co-managed to HAM	TRGTXEHMXXX (SSP-BIC of HAM)	S: Bank A (BKEEITWWXXX) - Co-managed R: TRGTXEHMXXX 20: TRN (assigned by sender) 21: Related Reference (assigned by sender) 32A: Value date, currency code and amount ... 57a: Debtor's/creditor's CB (NCBIITRRXXX)

2 Flow of payments/transactions

2.2 Liquidity transfer/Interbank transfer

2.2.1 Liquidity transfer with HAM

Message	BIC of respective SSP module	Field entry
		58a: Bank A (BKBBITRRXXX) – Co-manager, PM participant, Beneficiary Institution
② MT 900 (optional) from HAM to co-managed	TRGTXEHMXXX (SSP-BIC of HAM)	S: TRGTXEHMXXX R: Bank A (BKEEITWWXXX), sender of initial MT 202 “simplified” ①
		20: TRN by SSP 21: Field 20 (TRN) of initial MT 202 “simplified” ① 25: Account (which has been debited) Identification 32A: Value date, currency code and amount, field 32A of initial MT 202 “simplified” ① ... 52a: Bank A (BKEEITWWXXX) - Co-managed, “Ordering Institution”, sender of initial MT 202 “simplified” ① ... 72: /SETTIME/HHMMSSCC
③ MT 910 (optional) from HAM to the debtor/creditor’s CB	TRGTXEHMXXX (SSP-BIC of HAM)	S: TRGTXEHMXXX R: NCBIITRRXXX, debtor/creditor’s CB
		20: TRN by SSP 21: NEW 25: Account (which has been credited) Identification 32A: Value date, currency code and amount ... 52a: Bank A (BKBBITRRXXX) - Co-managed “Ordering Institution”, sender of initial MT 202 “simplified” (co-managed participant) ① ... 56a: Bank B (BKEEITWWXXX), ... 72: /SETTIME/HHMMSSCC /INTERMOD/
④ MT 900 (optional) from HAM to co-manager account	TRGTXEHMXXX (SSP-BIC of HAM)	S: TRGTXEHMXXX R: Co-manager (BKBBITRRXXX),
		20: TRN by SSP 21: NEW 25: Account (which has been debited) Identification

2 Flow of payments/transactions

2.2 Liquidity transfer/Interbank transfer

2.2.1 Liquidity transfer with HAM

Message	BIC of respective SSP module	Field entry
		32A: Value date, currency code and amount, field 32A of initial MT 202 “simplified” ① ... 52a: Bank A (BKEEITWWXXX) - Co-managed, HAM participant, “Ordering Institution”, sender of initial MT 202 “simplified” ① ... 72: /SETTIME/HHMMSSCC
⑦ MT 202 from PM to creditor	TRGTXEPMXXX (SSP-BIC of PM)	S: TRGTXEPMXXX R: Bank A (BKBBITRRXXX) - Co-manager, PM participant, field 58a of initial MT 202 “simplified” (= sender) ① ... 20: TRN by SSP 21: Field 21 of initial MT 202 “simplified” ① 32A: Value date, currency code and amount, field 32A of initial MT 202 “simplified” ① ... 52a: Bank B (BKEEITWWXXX), debtor, co-managed, HAM participant 53a: Debtor’s/creditor’s CB (NCBIITRRXXX), “sender’s correspondent”, field 57a of initial MT 202 “simplified” ① ... 58a: Bank A (BKBBITRRXXX) - Co-manager, PM participant, field 58a of initial MT 202 “simplified” (= sender) ①
⑧ MT 900 (optional) from PM to the debtor/creditor’s CB	TRGTXEPMXXX (SSP-BIC of PM)	S: TRGTXEPMXXX R: NCBIITRRXXX, debtor/creditor’s CB ... 20: TRN by SSP = field 20 ⑤ 21: Field 20 25: Account (which has been debited) Identification 32A: Value date, currency code and amount ... 52a: Debtor’s CB (NCBIITRRXXX) ...

2 Flow of payments/transactions

2.2 Liquidity transfer/Interbank transfer

2.2.1 Liquidity transfer with HAM

2.2.1.10.2 Same CB via ICM

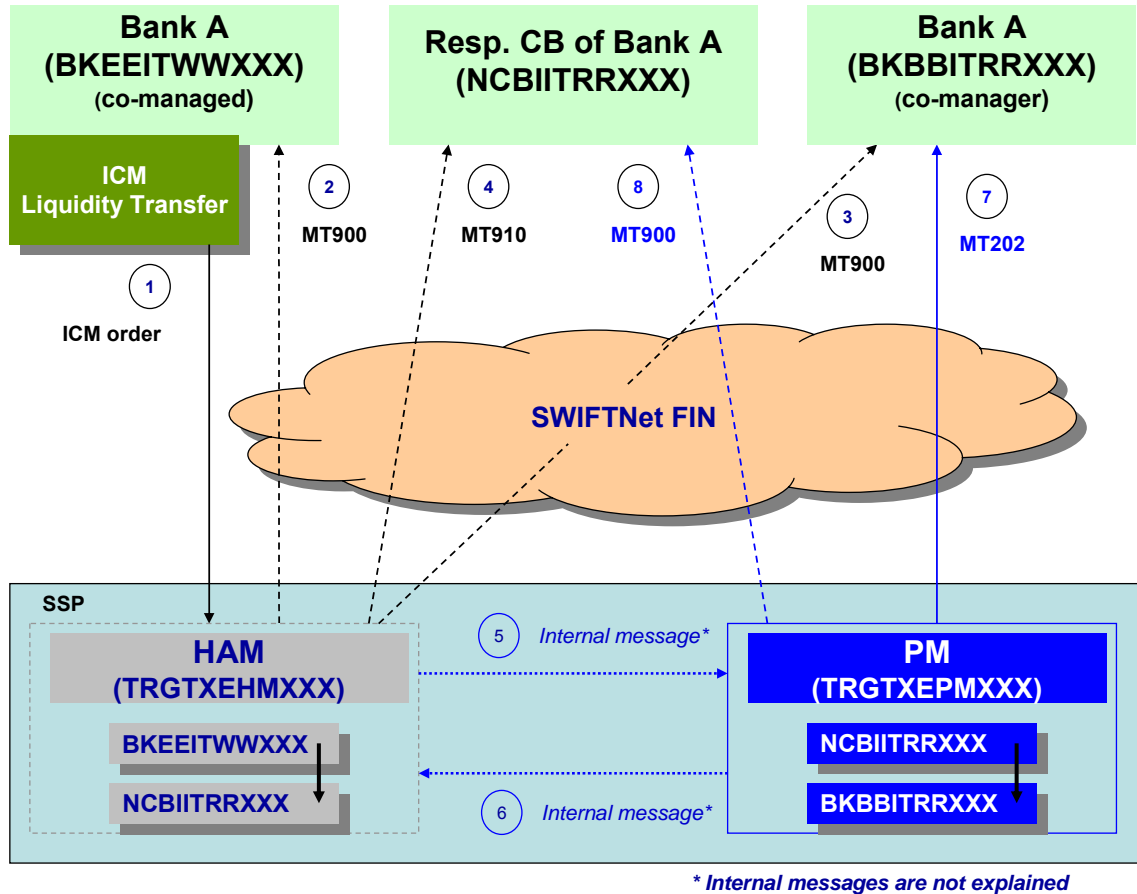

Message	BIC of respective SSP module	Field entry
① ICM order. Liquidity Transfer (other accounts)	N/A	S: N/A R: N/A
		Participant BIC: Ordering HAM account holder Bank A (BKEEITWWXXX) Counterpart for Liquidity Transfer - Participant BIC: Bank B (BKFFITMMXXX), creditor, Beneficiary Institution - Module: RTGS - Responsible CB: CB's Country Code of the counterpart (IT) - Liquidity transfer (EUR): amount

2 Flow of payments/transactions

2.2 Liquidity transfer/Interbank transfer

2.2.1 Liquidity transfer with HAM

Message	BIC of respective SSP module	Field entry
<p>② MT 900 (optional) from HAM to co-managed</p> <p>(only if the co-manager has chosen to receive it)</p>	<p>TRGTXEHMXXX (SSP-BIC of HAM)</p>	<p>S: TRGTXEHMXXX R: Bank A (BKEEITWWXXX), sender of initial MT 202 “simplified” ①</p> <p>20: TRN by SSP 21: Related Reference by SSP 25: Account (which has been debited) Identification 32A: Value date, currency code and amount, ... 52a: Bank A (BKEEITWWXXX) - Co-managed, “Ordering Institution”, via ICM ① ... /SETTIME/HHMMSSCC 72:</p>
<p>③ MT 910 (optional) from HAM to the debtor/creditor’s CB</p> <p>(only if the CB has chosen to receive it)</p>	<p>TRGTXEHMXXX (SSP-BIC of HAM)</p>	<p>S: TRGTXEHMXXX R: (NCBIITRRXXX), debtor/creditor’s CB</p> <p>20: TRN by SSP 21: NEW 25: Account (which has been credited) Identification 32A: Value date, currency code and amount ... 52a: Bank A (BKEEITWWXXX) - Co-managed “Ordering Institution”, via ICM ① ... Bank B (BKEEITWWXXX), 56a: debtor, field 53a of initial MT 202 “simplified” ① ... /SETTIME/HHMMSSCC 72: /INTERMOD/</p>
<p>④ MT 900 (optional) from HAM to co-manager account</p> <p>(only if the co-managed has chosen to receive it)</p>	<p>TRGTXEHMXXX (SSP-BIC of HAM)</p>	<p>S: TRGTXEHMXXX R: Co-manager (BKBBITRRXXX),</p> <p>20: TRN by SSP 21: NEW 25: Account (which has been debited) Identification 32A: Value date, currency code and amount, field 32A of initial MT 202 “simplified” ① ...</p>

2 Flow of payments/transactions

2.2 Liquidity transfer/Interbank transfer

2.2.1 Liquidity transfer with HAM

Message	BIC of respective SSP module	Field entry
		52a: Bank A (BKEEITWWXXX) - Co-managed, HAM participant, "Ordering Institution", sender of initial MT 202 "simplified" ① ... 72: /SETTIME/HHMMSSCC
⑦ MT 202 from PM to creditor	TRGTXEPMXXX (SSP-BIC of PM)	S: TRGTXEPMXXX R: Bank B (BKBBITRRXXX) - Co-manager, PM participant, field 58a of initial MT 202 "simplified" (= sender) ① 20: TRN by SSP 21: ICM 32A: Value date, currency code and amount, field 32A of initial MT 202 "simplified" ① ... 52a: Bank A (BKEEITWWXXX), debtor, co-managed, HAM participant 53a: Debtor's/creditor's CB (NCBIITRRXXX), "sender's correspondent", CB of HAM account holder ... 58a: Bank B (BKBBITRRXXX) - Co-manager, Counterpart for Liquidity Transfer ①
⑧ MT 900 (optional) from PM to the debtor/creditor's CB (only if the CB has chosen to receive it)	TRGTXEPMXXX (SSP-BIC of PM)	S: TRGTXEPMXXX R: NCBIITRRXXX, debtor/creditor's CB 20: TRN by SSP = field 20 ② 21: Field 20 25: Account (which has been debited) Identification 32A: Value date, currency code and amount ... 52a: Debtor's CB (NCBIITRRXXX) ...

2 Flow of payments/transactions

2.2 Liquidity transfer/Interbank transfer

2.2.1 Liquidity transfer with HAM

2.2.1.11 Interbank transfer from “HAM account” to the RTGS account of the co-manager initiated by the co-managed. Different CB.

Co-managed participants are allowed to send payment via ICM or SWIFT to the RTGS account of the related co-manager. However the flow of messages is not explained in this document.

2 Flow of payments/transactions

2.2 Liquidity transfer/Interbank transfer

2.2.2 Liquidity transfer with PHA

2.2.2 Liquidity transfer with PHA

2.2.2.1 Liquidity transfer from PHA to PM via SWIFT

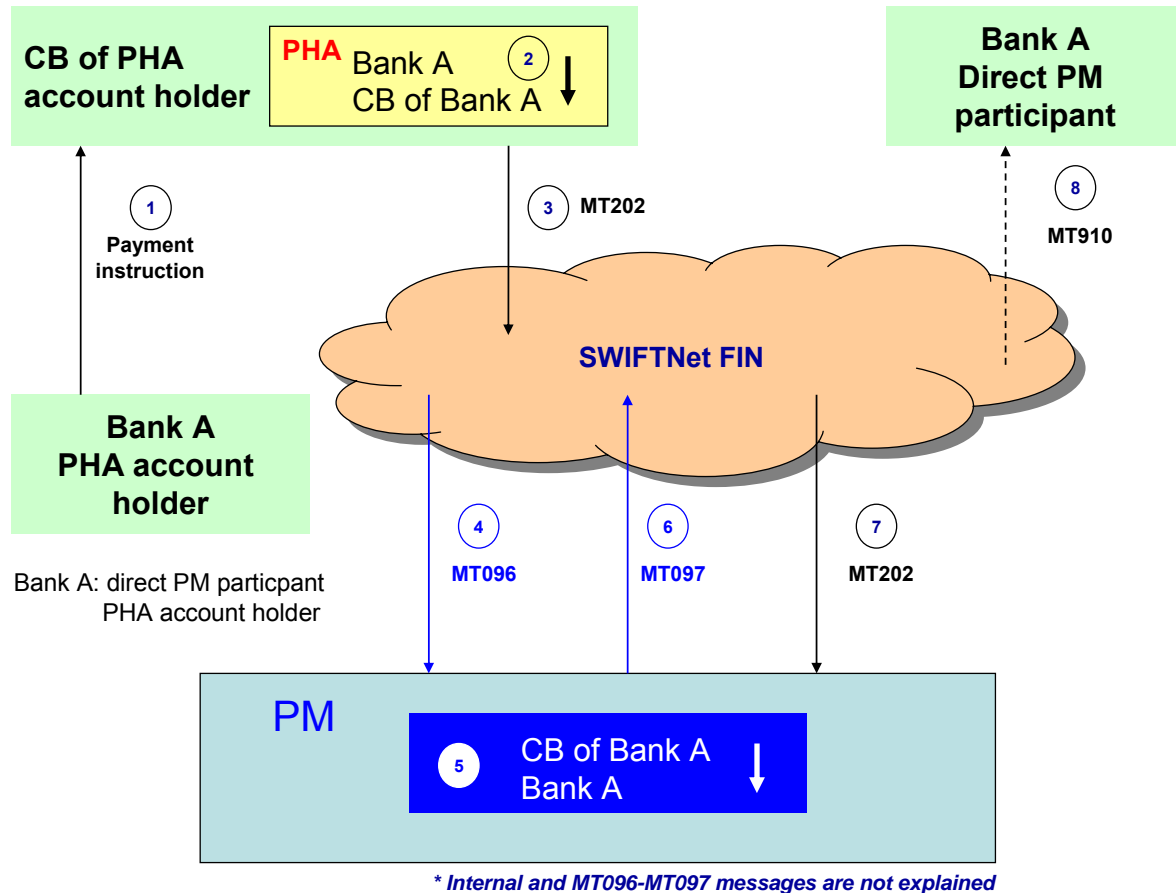

Message	BIC of respective SSP-Module	Field entry
① Payment instruction		- outside the scope of SSP -
② Booking		Debit entry on PHA account of PHA account holder (Bank A) and credit entry on CB account in PHA
③ MT 202 from CB of PHA account holder	TRGTXEPMXXX (SSP BIC of PM)	S: CB of PHA account holder R: TRGTXEPMXXX 103: TGT (service identifier)

2 Flow of payments/transactions

2.2 Liquidity transfer/Interbank transfer

2.2.2 Liquidity transfer with PHA

		20: TRN 21: Related Reference 32A: Value date, currency code and amount ... 52a: PHA account holder (Bank A) ... 58a: PHA account holder (Bank A) = direct PM participant (Bank A) ... <hr/> Note: Priority – urgent or normal
⑤ Booking		PM debits the RTGS account of CB of PHA account holder and credits the account of direct PM participant (Bank A) in PM
⑦ MT 202 sent by SWIFT to SSP-PM	TRGTXEPMXXX (SSP-BIC of PM)	Message from ③ (Y-Copy)
⑧ MT 910 (optional) from PM to direct PM participant (PHA account holder)	TRGTXEPMXXX (SSP-BIC of PM)	S: TRGTXEPMXXX R: direct
		20: TRN by SSP 21: Field 21 (Rel Ref) of initial MT 202 ③ 25: Account of PHA account holder (credited) 32A: Value date, currency code and amount ... 52a: PHA account holder (Bank A) ... 72: /LIQUIINP/

2 Flow of payments/transactions

2.2 Liquidity transfer/Interbank transfer

2.2.2 Liquidity transfer with PHA

2.2.2.2 Liquidity transfer from PHA to PM via ICM

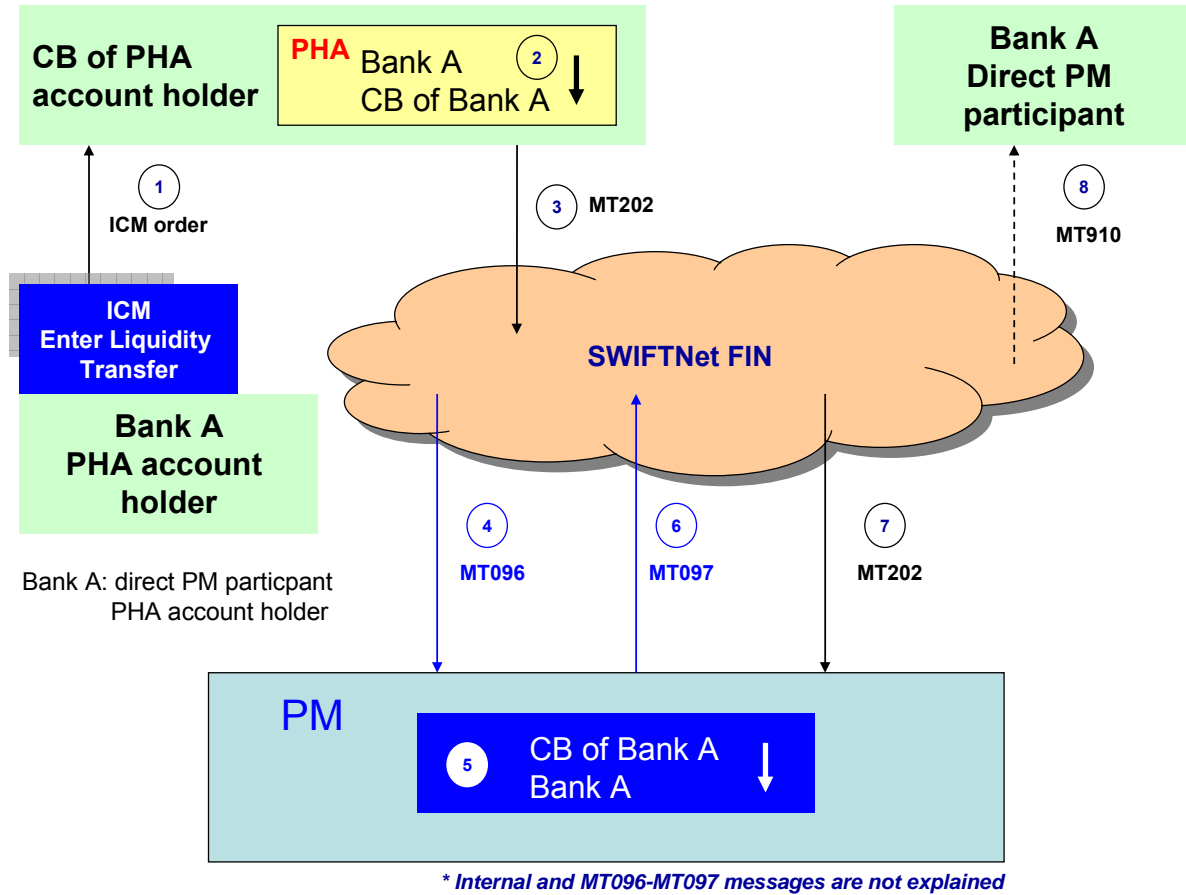

Message	BIC of respective SSP-Module	Field entry
① ICM order from PHA account holder to PM direct participant	N/A	S: N/A R: N/A
		Screen: Enter Liquidity Transfer Transfer from PHA to PM Amount
② Booking		Debit entry on PHA account of PHA account holder (Bank A) and credit entry on CB account in PHA

2 Flow of payments/transactions

2.2 Liquidity transfer/Interbank transfer

2.2.2 Liquidity transfer with PHA

<p>③ MT 202 from CB of PHA account holder to PHA account holder (Bank A) = direct PM participant (Bank A)</p>	<p>TRGTXEPMXXX (SSP BIC of PM)</p>	<p>S: CB of PHA account holder R: TRGTXEPMXXX 103: TGT (service identifier)</p> <hr/> <p>20: TRN 21: Related Reference 32A: Value date, currency code and amount ... 52a: PHA account holder (Bank A) ... 58a: PHA account holder (Bank A) = direct PM participant (Bank A) ... Note: Priority – urgent or normal</p>
<p>⑤ Booking</p>		<p>PM debits the RTGS account of CB of PHA account holder and credits the account of direct PM participant (Bank A) in PM</p>
<p>⑦ MT 202 sent by SWIFT to SSP-PM</p>	<p>TRGTXEPMXXX (SSP-BIC of PM)</p>	<p>Message from ③ (Y-Copy)</p>
<p>⑧ MT 910 (<i>optional</i>) from PM to direct PM participant (PHA account holder)</p>	<p>TRGTXEPMXXX (SSP-BIC of PM)</p>	<p>S: TRGTXEPMXXX R: direct</p> <hr/> <p>20: TRN by SSP 21: Field 21 (Rel Ref) of initial MT 202 ③ 25: Account of PHA account holder (credited)</p> <hr/> <p>32A: Value date, currency code and amount ... 52a: PHA account holder (Bank A) ... 72: /LIQUIINP/</p>

2 Flow of payments/transactions

2.2 Liquidity transfer/Interbank **transfer**

2.2.2 Liquidity transfer **with PHA**

2.2.2.3 Liquidity transfer from a PHA account holder to a direct PM participant during the business day

See 2.2.2.1 with the priority “urgent”.

2 Flow of payments/transactions

2.2 Liquidity transfer/Interbank transfer

2.2.2 Liquidity transfer with PHA

2.2.2.4 Liquidity transfer from direct PM participant to PHA account holder via SWIFT.

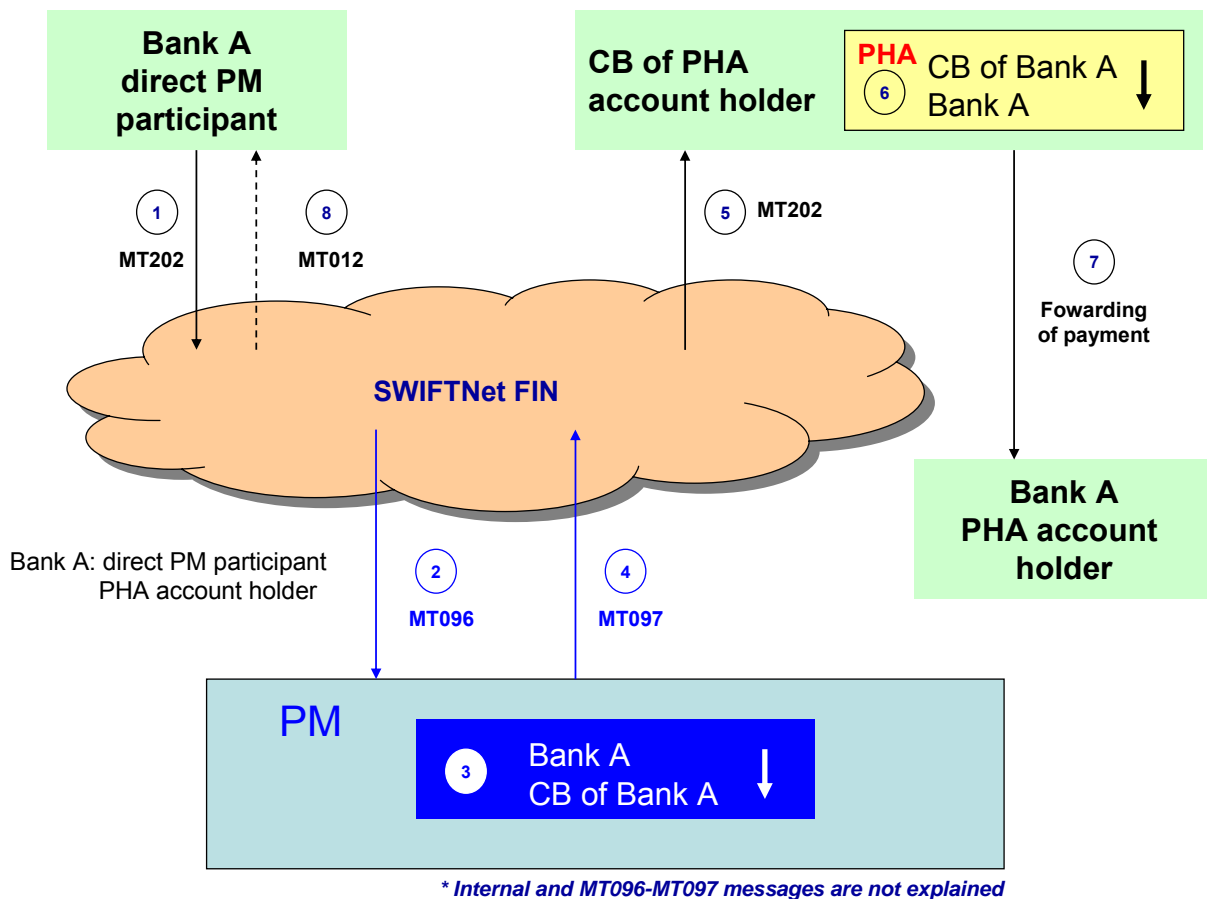

Message	BIC of respective SSP-Module	Field entry
① MT 202 from direct PM participant to PHA		S: Direct PM participant R: CB's BIC of PHA account holder 103: TGT (service identifier)

2 Flow of payments/transactions

2.2 Liquidity transfer/Interbank transfer

2.2.2 Liquidity transfer with PHA

		20: TRN 21: Related Reference 32A: Value date, currency code and amount ... 52a: Direct PM participant =PHA account holder (Bank A) ... 58a: PHA account holder (Bank A) ...
③ Booking		PM debits the RTGS account of direct PM participant and credits the account of CB with PHA in PM
⑤ MT 202 to PHA account holder	TRGTXEPMXXX (SSP-BIC of PM)	Message from ① (Y-Copy)
⑥ Booking		Debit entry on CB account and credit entry on account of PHA account holder in PHA
⑦ Forwarding of payment		- outside the scope of SSP -
⑧ MT 012 (optional)		S: SWIFT system R: Direct PM participant 175: Input time of the initial MT 202 ① 106: Message Input Reference (MIR) of the initial MT 202 ① 108: Message User Reference (MUR) if filled, else: TRN of initial MT 202 ① 102: SWIFT address of receiver (complete 12 character destination) 103: TGT (service identifier) 114: Payment-release-information-sender (credit and debit time, country code of sender and reference of the initial MT 202 (field 20 ①))

2 Flow of payments/transactions

2.2 Liquidity transfer/Interbank transfer

2.2.2 Liquidity transfer with PHA

2.2.2.5 Liquidity transfer from direct PM participant to PHA account holder via ICM.

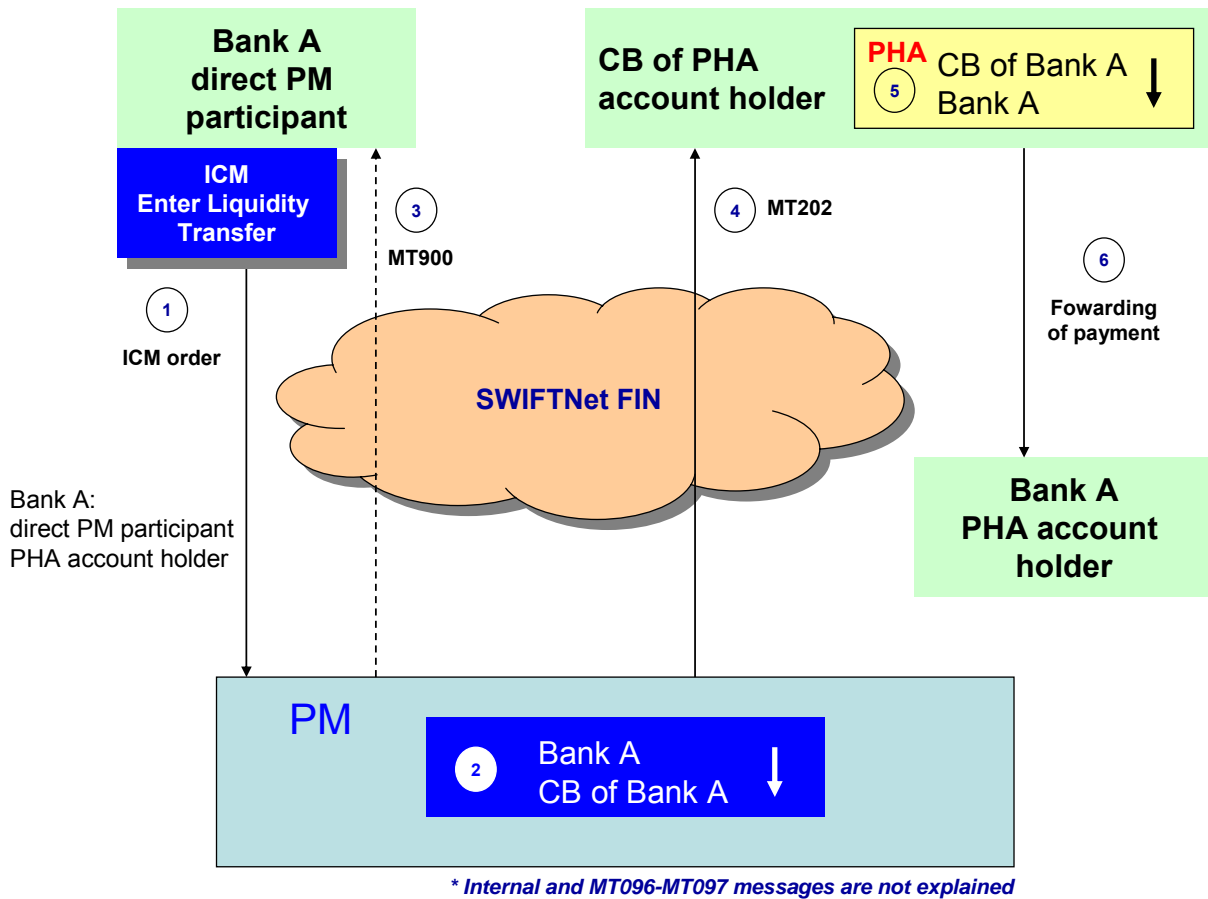

Message	BIC of respective SSP-Module	Field entry
① ICM order from direct PM participant to PHA account holder	N/A	S: N/A R: N/A Screen: Enter Liquidity Transfer Transfer from PM to PHA Amount
② Booking		PM debits the RTGS account of direct PM participant and credits the account of CB with PHA in PM

2 Flow of payments/transactions

2.2 Liquidity transfer/Interbank transfer

2.2.2 Liquidity transfer with PHA

③ MT 900 (<i>optional</i>) to direct PM participant	TRGTXEPMXXX (SSP-BIC of PM)	S: TRGTXEPMXXX R: PM participant (Bank A)
		20: TRN by SSP 21: NONREF 25: RTGS account number 32A: Value date, currency code and amount 52a: Direct PM participant =PHA account holder (Bank A) 72 /LIQUIOUT/
④ MT 202 to CB of PHA ...account holder	TRGTXEPMXXX (SSP-BIC of PM)	S: TRGTXEPMXXX R: CB's BIC of PHA account holder
		20 TRN by SSP 21 Related reference by SSP (same as TRN) 32A Value date, currency code and amount 52a Direct PM participant =PHA account holder (Bank A) 58a /Account for liquidity removal during the day PHA account holder (Bank A)
⑤ Booking		Debit entry on CB account and credit entry on account of PHA account holder in PHA
⑥ Forwarding of payment		- outside the scope of SSP -

2 Flow of payments/transactions

2.2 Liquidity transfer/Interbank transfer

2.2.2 Liquidity transfer with PHA

2.2.2.6 Liquidity transfer from direct PM participant to PHA account holder at the End of Day.

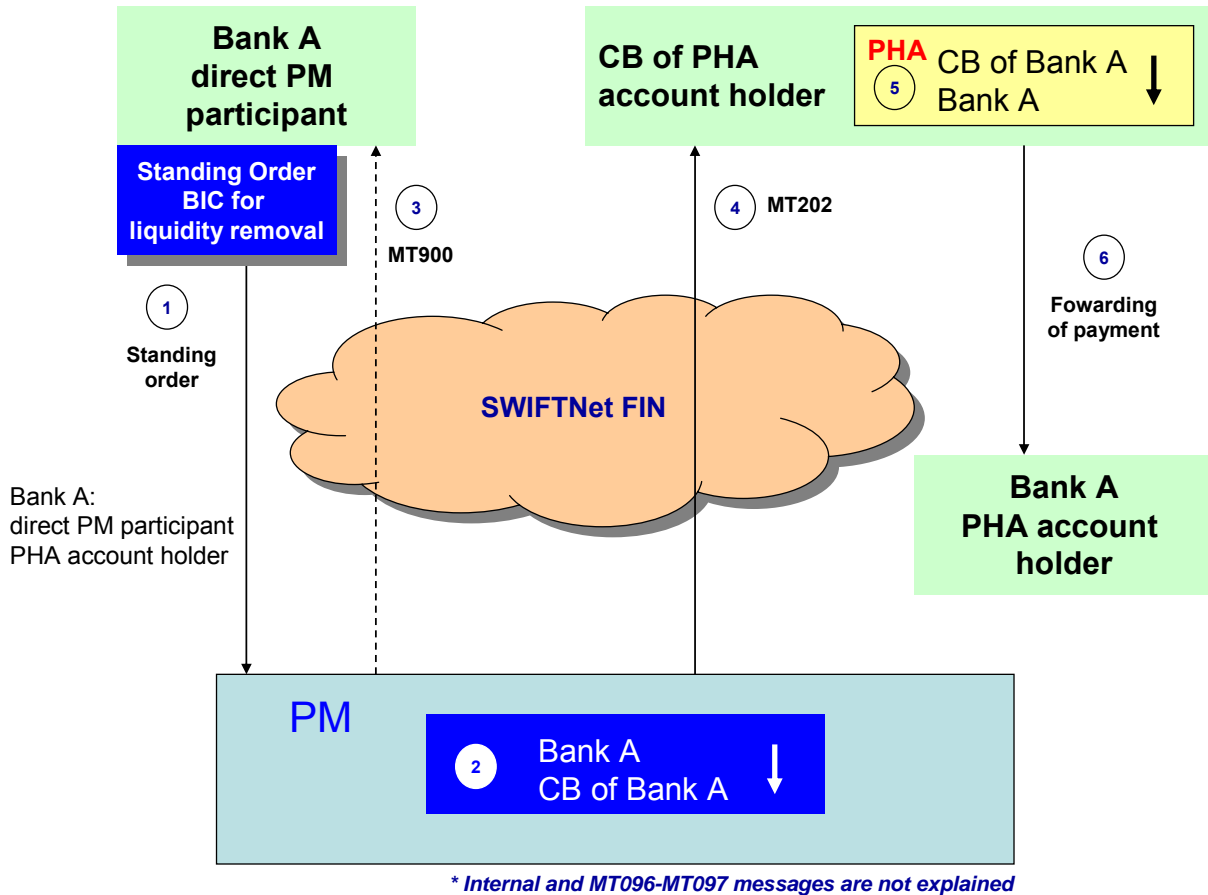

Message	BIC of respective SSP-Module	Field entry
① Standing order from direct PM participant to PHA account holder	N/A	Standing order
		Transfer from PM to PHA BIC for liquidity removal at EoD= CB's BIC
② Booking		PM debits the RTGS account of direct PM participant and credits the account of CB with PHA in PM
③ MT 900 (optional) to direct PM participant	TRGTXEPMXXX (SSP-BIC of PM)	S: TRGTXEPMXXX R: PM participant (Bank A)

2 Flow of payments/transactions

2.2 Liquidity transfer/Interbank transfer

2.2.2 Liquidity transfer with PHA

		20: TRN by SSP 21: Related reference by SSP (same as TRN) 25: RTGS account number 32A: Value date, currency code and amount 52a: Direct PM participant =PHA account holder (Bank A) 72 /LIQUIEOD/
④ MT 202 to CB of PHA account holder	TRGTXEPMXXX (SSP-BIC of PM)	S: TRGTXEPMXXX R: CB's BIC of PHA account holder
		20 TRN by SSP 21 Related reference by SSP (same as TRN) 32A Value date, currency code and amount 52a Direct PM participant =PHA account holder (Bank A) 58a /Account number for liquidity removal at EoD PHA account holder (Bank A)
⑤ Booking		Debit entry on CB account and credit entry on account of PHA account holder in PHA
⑥ Forwarding of payment		- outside the scope of SSP -

2 Flow of payments/transactions

2.2 Liquidity transfer/Interbank transfer

2.2.3 Liquidity transfer between group of account members

2.2.3 Liquidity transfer between group of account members

2.2.3.1 Liquidity transfer between group of account members via ICM

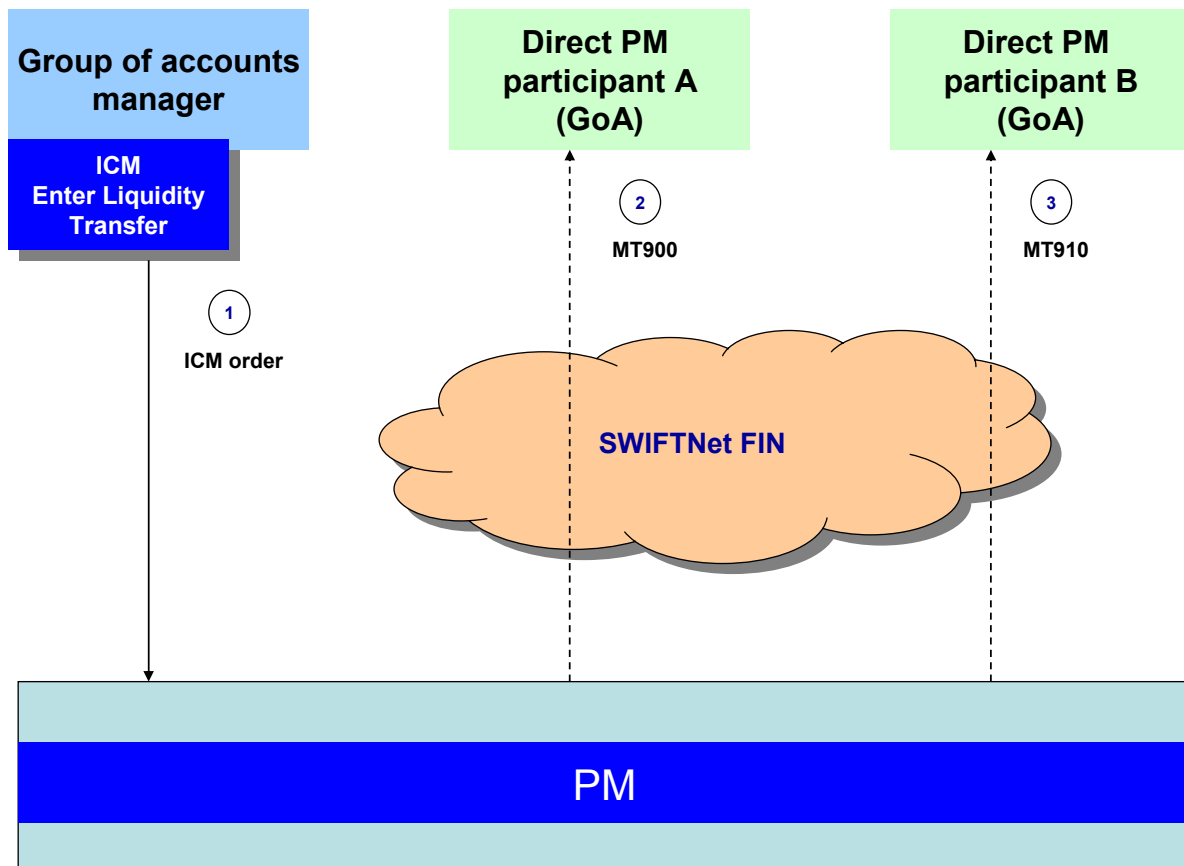

* Internal and MT096-MT097 messages are not explained

Message	BIC of respective SSP-Module	Field entry
① ICM order by group of account manager	N/A	S: N/A R: N/A
		Screen: Enter Liquidity Transfer Transfer from direct PM participant A to direct PM participant B (In the previous screen A and B have to be selected from the list in which all the members of the GoA are displayed)
		Amount

2 Flow of payments/transactions

2.2 Liquidity transfer/Interbank transfer

2.2.3 Liquidity transfer between group of account members

② MT 900 (<i>optional</i>) to direct PM participant A	TRGTXEPMXXX (SSP-BIC of PM)	S: TRGTXEPMXXX R: PM participant A
		20: TRN by SSP 21: Related reference by SSP (same as TRN) 25: RTGS account number of A 32A: Value date, currency code and amount 52a: Ordering BIC 72 /LIQUIOUT/
③ MT 910 (<i>optional</i>) to direct PMparticipant B	TRGTXEPMXXX (SSP-BIC of PM)	S: TRGTXEPMXXX R: PM participant B
		20: TRN by SSP 21: Related reference by SSP (same as TRN) 25: RTGS account number of B 32A: Value date, currency code and amount 52a: Ordering BIC 72 /LIQUIINP/

2 Flow of payments/transactions

2.3 Direct debits

2.3.1 Debiting a direct participant

2.3 Direct debits

2.3.1 Debiting a direct participant

2.3.1.1 From CI as direct participant

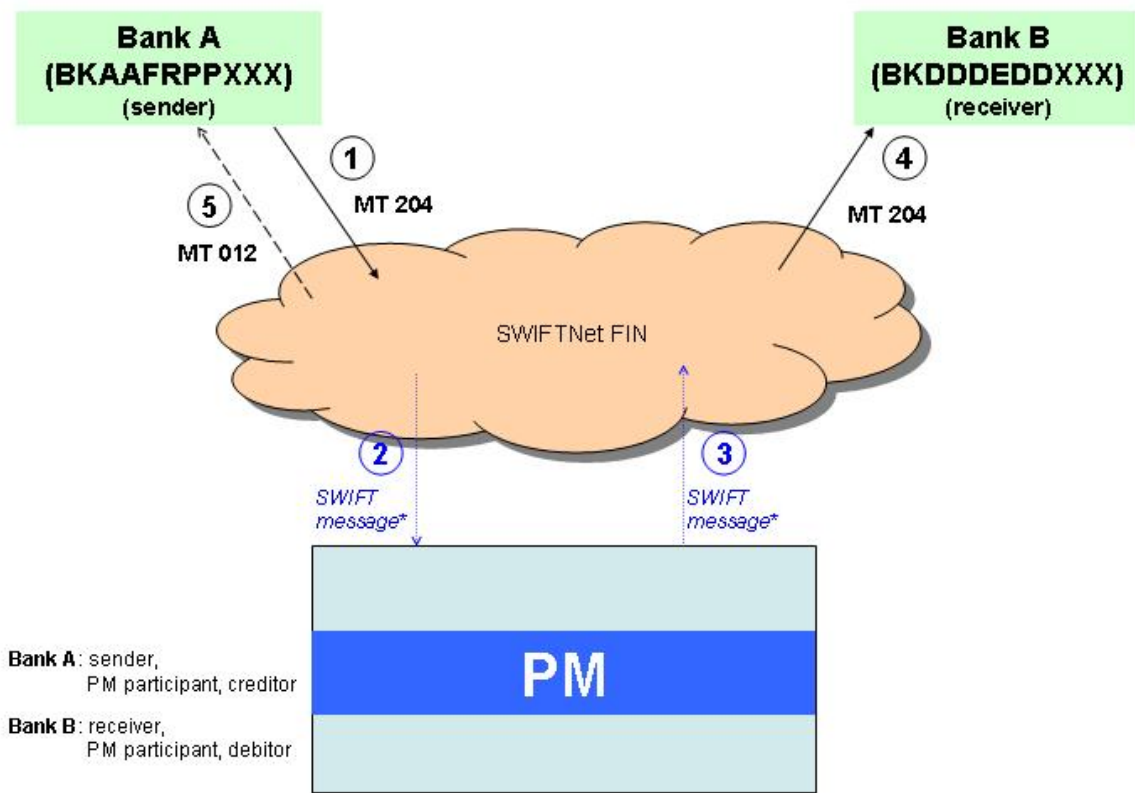

* Internal and SWIFT messages are not explained

Message	BIC of respective SSP module	Field entry
① MT 204 from Bank A to Bank B		S: Bank A (BKA AFRPPXXX) R: Bank B (BK DDEDDXXX) 103: TGT (service identifier)
		Sequence A Common Elements – Reimbursement Details

2 Flow of payments/transactions

2.3 Direct debits

2.3.1 Debiting a direct participant

Message	BIC of respective SSP module	Field entry
		20: TRN 19: Sum of Amounts 30: Value Date ... Repetitive Sequence B – Transaction Details
		20: TRN ... 32B: Transaction Amount 53a: Bank B (BKDDDEDDXXX) ...
④ MT 204 from Bank A to Bank B		Message from ①
⑤ MT 012 (<i>optional</i>)		S: SWIFT system R: Bank A (BKAAFRPPXXX) 175: Input time of the initial MT 204 ① 106: Message Input Reference (MIR) of the initial MT 204 ① 108: Message User Reference (MUR) if filled, else: TRN of initial MT 204 ① 102: SWIFT address of receiver (complete 12 character destination) 103: TGT (service identifier) 114: Payment-release-information-sender (credit and debit time, country code of sender and reference of the initial MT 204 (field 20) ①)

2 Flow of payments/transactions

2.3 Direct debits

2.3.1 Debiting a direct participant

2.3.1.2 From CI as direct participant using a second BIC

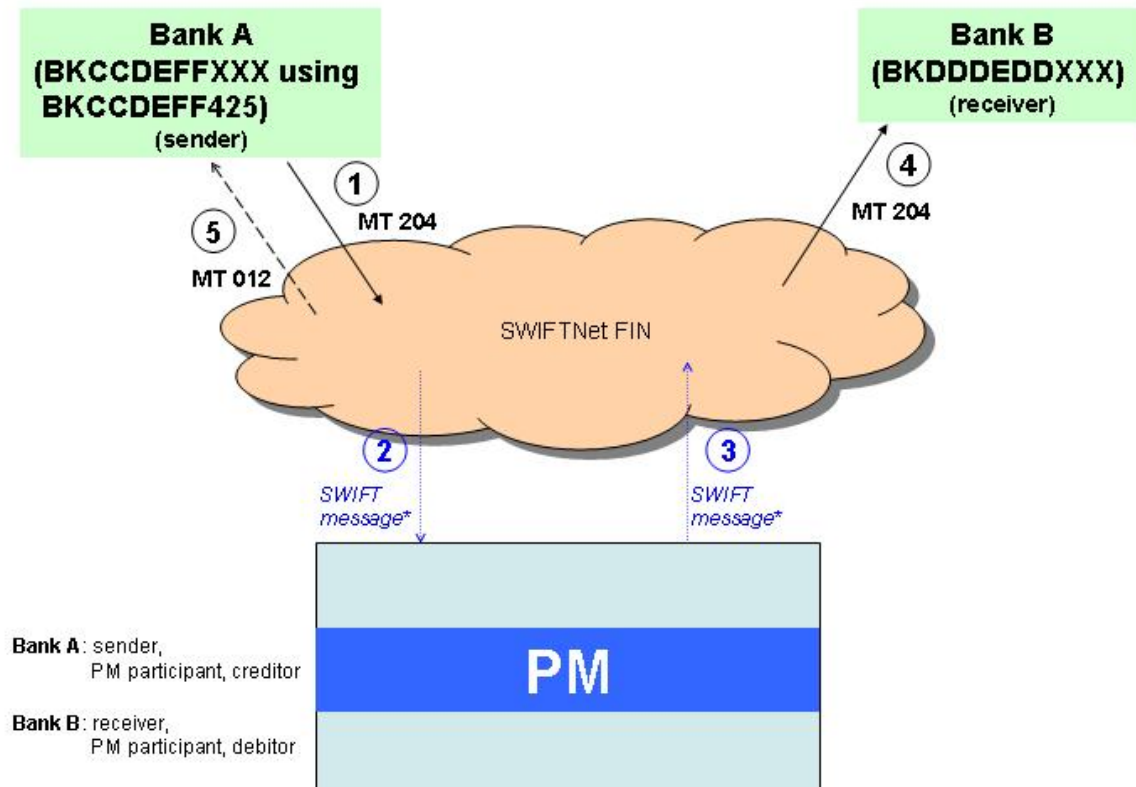

* Internal and SWIFT messages are not explained

Message	BIC of respective SSP module	Field entry
① MT 204 from Bank A to Bank B		S: Bank A using a second BIC (BKCCDEFF425) R: Bank B (BKDDDEDDXXX) 103: TGT (service identifier)
		Sequence A Common Elements – Reimbursement Details
		20: TRN 19: Sum of Amounts 30: Value Date ...

2 Flow of payments/transactions

2.3 Direct debits

2.3.1 Debiting a direct participant

Message	BIC of respective SSP module	Field entry
		Repetitive Sequence B – Transaction Details 20: TRN ... 32B: Transaction Amount 53a: Bank B (BKDDDEDDXXX), Debit Institution
④ MT 204 from Bank A to Bank B		Message from ①
⑤ MT 012 (<i>optional</i>)		S: SWIFT system R: Bank A using a second BIC (BKCCDEFF425), sender of initial MT 204 ① 175: Input time of the initial MT 204 ① 106: Message Input Reference (MIR) of the initial MT 204 ① 108: Message User Reference (MUR) if filled, else: TRN of initial MT 204 ① 102: SWIFT address of receiver (complete 12 character destination) 103: TGT (service identifier) 114: Payment-release-information-sender (credit and debit time, country code of sender and reference of the initial MT 204 (field 20) ①)

2 Flow of payments/transactions

2.3 Direct debits

2.3.1 Debiting a direct participant

2.3.1.3 From CI as indirect participant

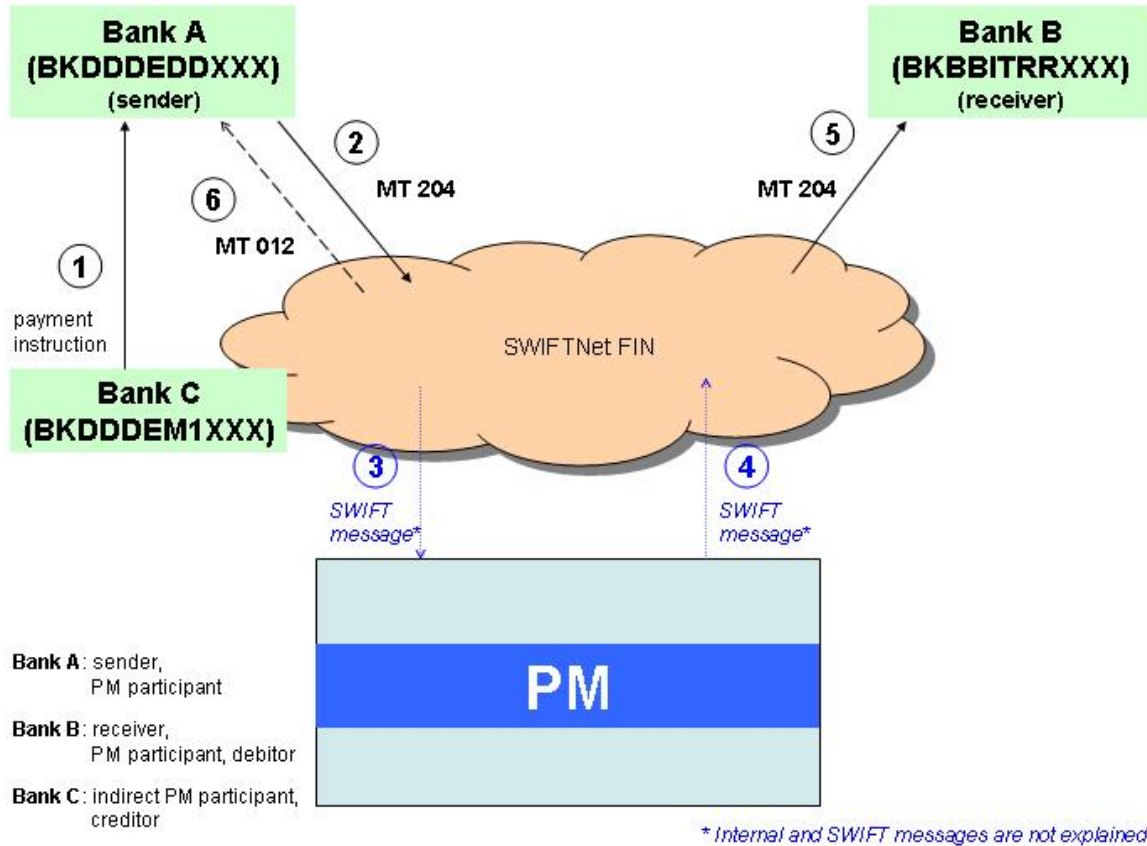

Message	BIC of respective SSP module	Field entry
① Payment instruction		- outside the scope of SSP -
② MT 204 from Bank A to Bank B		S: Bank A (BKDDDEDDXXX) (to whom the indirect participant BKDDDEM1XXX is related) R: Bank B (BKBBITRRXXX) 103: TGT (service identifier)
		Sequence A Common Elements – Reimbursement Details

2 Flow of payments/transactions

2.3 Direct debits

2.3.1 Debiting a direct participant

Message	BIC of respective SSP module	Field entry
		20: TRN 19: Sum of Amounts 30: Value Date 58a: Indirect participant (BKDDDEM1XXX)
		Repetitive Sequence B – Transaction Details
		20: TRN ... 32B: Transaction Amount 53a: Bank B (BKBBITRRXXX) ...
⑤ MT 204 from Bank A to Bank B		Message from ②
⑥ MT 012 (optional)		S: SWIFT system R: Bank A (BKDDDEDDXXX), sender of initial MT 204
		175: Input time of the initial MT 204 ② 106: Message Input Reference (MIR) of the initial MT 204 ② 108: Message User Reference (MUR) if filled, else: TRN of initial MT 204 ② 102: SWIFT address of receiver (complete 12 character destination) 103: TGT (service identifier) 114: Payment-release-information-sender (credit and debit time, country code of sender and reference of the initial MT 204 (field 20) ②)

2 Flow of payments/transactions

2.3 Direct debits

2.3.2 Debiting an indirect participant

2.3.2 Debiting an indirect participant

2.3.2.1 From CI as direct participant

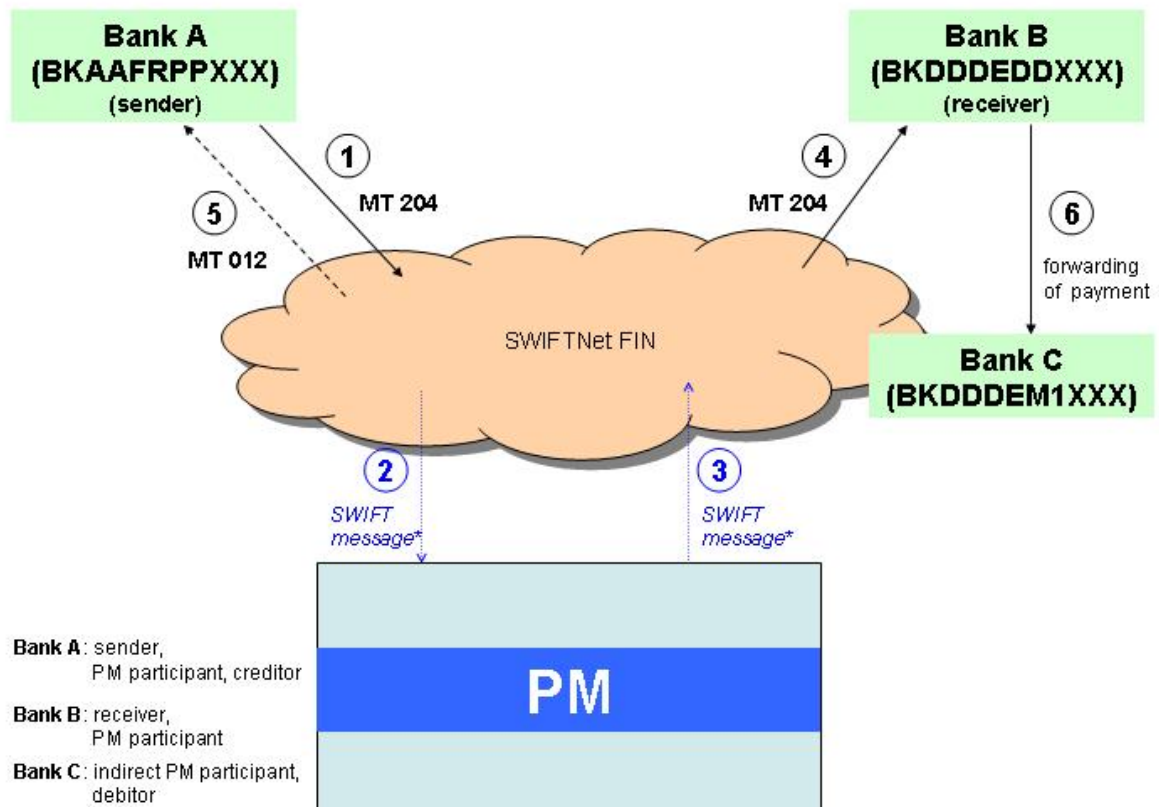

* Internal and SWIFT messages are not explained

Message	BIC of respective SSP module	Field entry
① MT 204 from Bank A to Bank B		S: Bank A (BKAARPPXXX) R: Bank B (BKDDDEDDXXX) 103: TGT (service identifier)
		Sequence A Common Elements – Reimbursement Details

2 Flow of payments/transactions

2.3 Direct debits

2.3.2 Debiting an indirect participant

Message	BIC of respective SSP module	Field entry
		20: TRN 19: Sum of Amounts 30: Value Date ... Repetitive Sequence B – Transaction Details
		20: TRN ... 32B: Transaction Amount 53a: Bank C (BKDDDEM1XXX) ...
④ MT 204 from Bank A to Bank B		Message from ①
⑤ MT 012 (optional)		S: SWIFT system R: Bank A (BKAAFRPPXXX), sender of initial MT 204 175: Input time of the initial MT 204 ① 106: Message Input Reference (MIR) of the initial MT 204 ① 108: Message User Reference (MUR) if filled, else: TRN of initial MT 204 ① 102: SWIFT address of receiver (complete 12 character destination) 103: TGT (service identifier) 114: Payment-release-information-sender (credit and debit time, country code of sender and reference of the initial MT 204 (field 20) ①)
⑥ Forwarding of payment		

2 Flow of payments/transactions

2.3 Direct debits

2.3.2 Debiting an indirect participant

2.3.2.2 From CI as direct participant using a second BIC

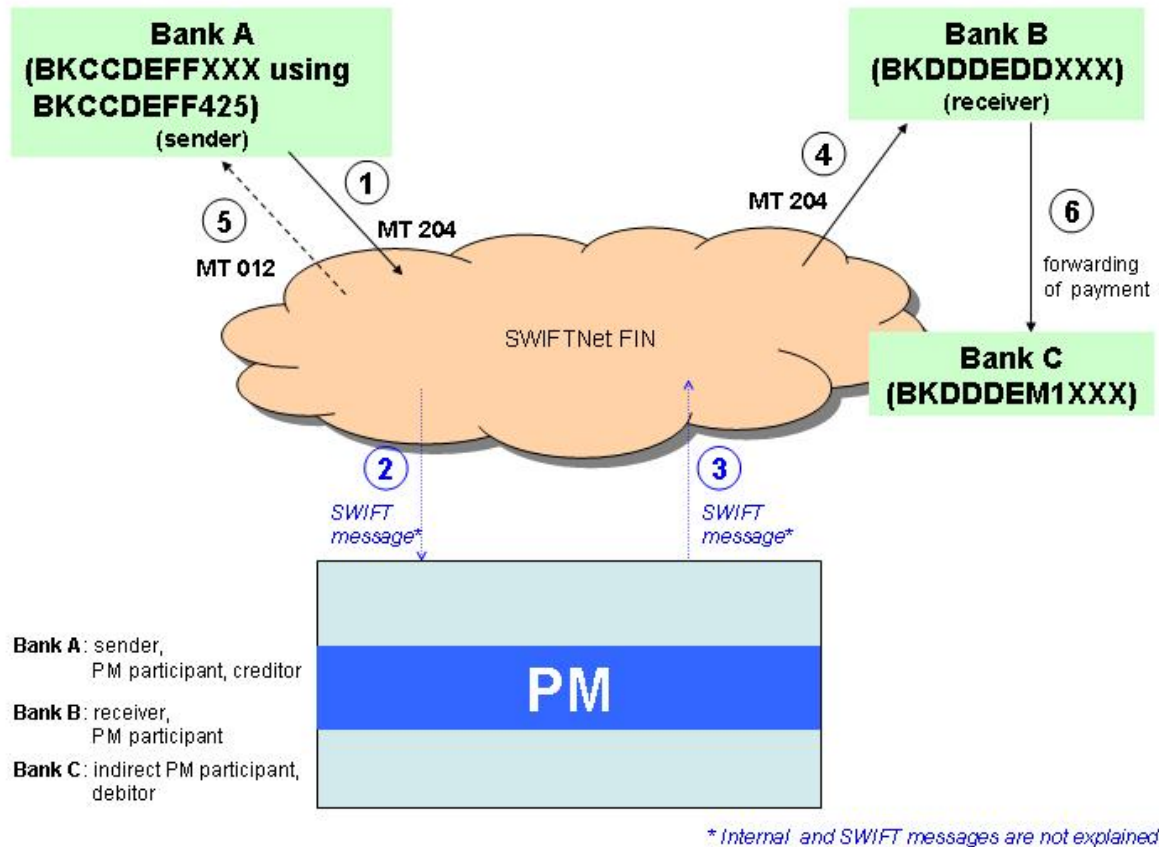

Message	BIC of respective SSP module	Field entry
① MT 204 from Bank A to Bank B		S: Bank A using a second BIC (BKCCDEFF425) R: Bank B (BKDDDEDDXXX) 103: TGT (service identifier)
		Sequence A Common Elements – Reimbursement Details
		20: TRN 19: Sum of Amounts 30: Value Date ...

2 Flow of payments/transactions

2.3 Direct debits

2.3.2 Debiting an indirect participant

Message	BIC of respective SSP module	Field entry
		Repetitive Sequence B – Transaction Details 20: TRN ... 32B: Transaction Amount 53a: Bank C (BKDDDEM1XXX) ...
④ MT 204 from Bank A to Bank B		Message from ①
⑤ MT 012 (<i>optional</i>)		S: SWIFT system R: Bank A using a second BIC (BKCCDEFF425), sender of initial MT 204 ① 175: Input time of the initial MT 204 ① 106: Message Input Reference (MIR) of the initial MT 204 ① 108: Message User Reference (MUR) if filled, else: TRN of initial MT 204 ① 102: SWIFT address of receiver (complete 12 character destination) 103: TGT (service identifier) 114: Payment-release-information-sender (credit and debit time, country code of sender and reference of the initial MT 204 (field 20) ①)
⑥ Forwarding of payment		

2 Flow of payments/transactions

2.3 Direct debits

2.3.2 Debiting an indirect participant

2.3.2.3 From CI as indirect participant

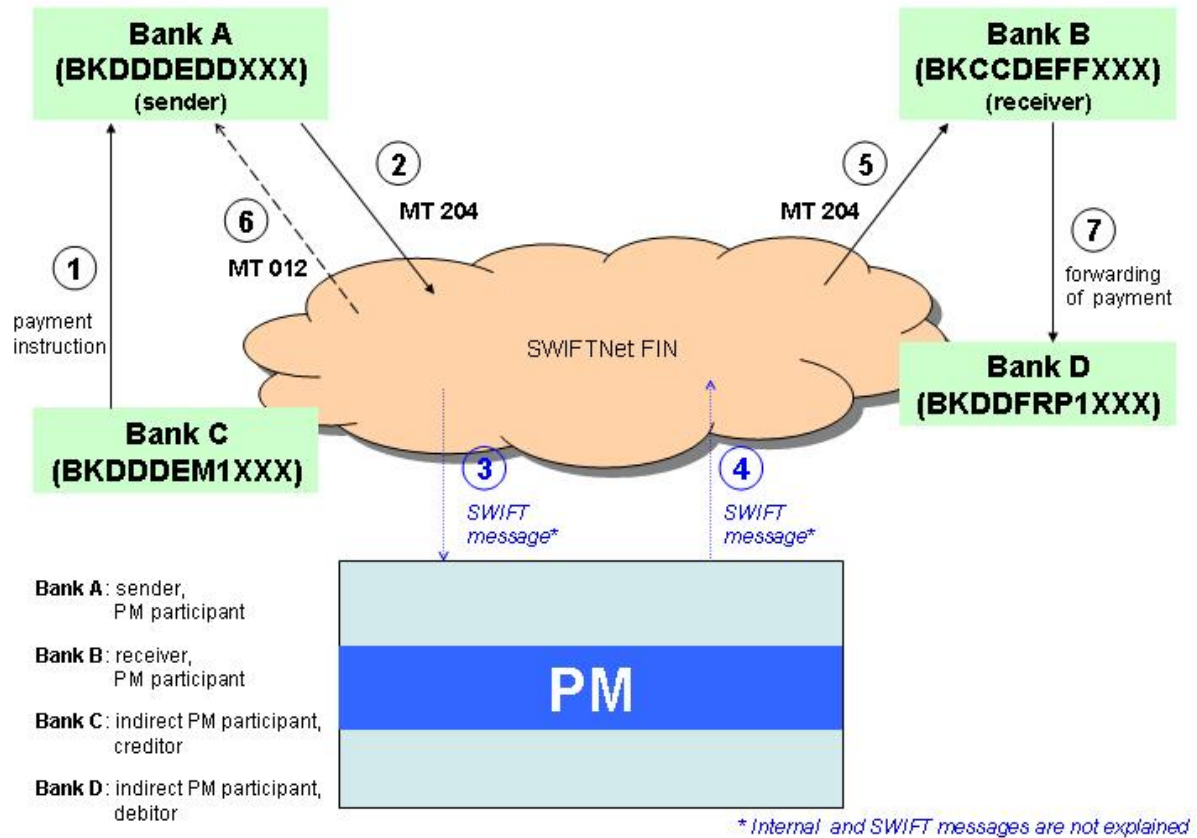

Message	BIC of respective SSP module	Field entry
① Payment instruction		- outside the scope of SSP -
② MT 204 from Bank A to Bank B		S: Bank A (BKDDDEDDXXX) (to whom the indirect participant BKDDDEM1XXX is related) R: Bank B (BKBBITRRXXX)(to whom the indirect participant/debtor BKDDFRP1XXX is related) 103: TGT (service identifier) Sequence A Common Elements – Reimbursement Details

2 Flow of payments/transactions

2.3 Direct debits

2.3.2 Debiting an indirect participant

Message	BIC of respective SSP module	Field entry
		20: TRN 19: Sum of Amounts 30: Value Date 58a: Indirect participant, Bank C (BKDDDEM1XXX)
		Repetitive Sequence B – Transaction Details
		20: TRN ... 32B: Transaction Amount 53a: Indirect participant, Bank D (BKDDFRP1XXX) ...
⑤ MT 204 from Bank A to Bank B		Message from ②
⑥ MT 012 (optional)		S: SWIFT system R: Bank A (BKDDDEDDXXX), sender of initial MT 204 ②
		175: Input time of the initial MT 204 ② 106: Message Input Reference (MIR) of the initial MT 204 ② 108: Message User Reference (MUR) if filled, else: TRN of initial MT 204 ② 102: SWIFT address of receiver (complete 12 character destination) 103: TGT (service identifier) 114: Payment-release-information-sender (credit and debit time, country code of sender and reference of the initial MT 204 (field 20) ②)
⑦ Forwarding of payment		

2 Flow of payments/transactions

2.4 AS transactions

2.4.1 Liquidity transfer

2.4 AS transactions

2.4.1 Liquidity transfer

2.4.1.1 Debit the mirror account and credit the settlement bank account

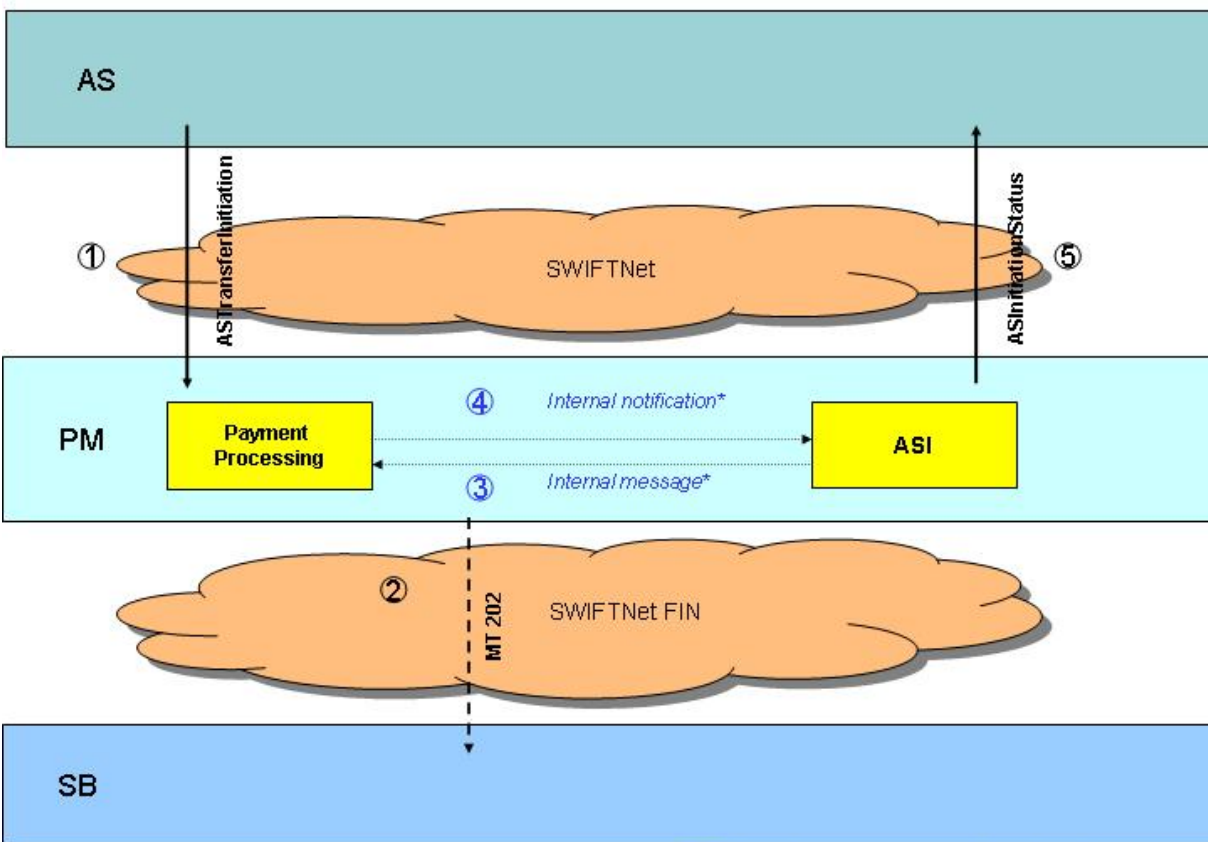

*) Internal messages are not explained

Message	Tag/field of message	Field entry
① ASInitiation from Ancillary System to PM	<Grpld>ABCDE1234</Grpld>	Unique ID for the file (assigned by AS)
	<InitgPty>	BIC of AS if CB sends this message on its behalf – InitiatingParty
	▶ <BIC>INNDNL2UXXX</BIC>	
	<DbtrAcct>	Third party's/ordering institution's account to be debited (debtor)
	▶ <Id>ABC1234</Id>	

2 Flow of payments/transactions

2.4 AS transactions

2.4.1 Liquidity transfer

	<p><FrstAgt> ▶ <BIC>BBBGBRAAXX</BIC></p> <p><PmtTx> ▶ <PmtId> <InstrId>EFG1234</InstrId> ▶ <EndToEndId>XYZ456</EndToEndId> ▶ <InstAmt>12345678.90</InstAmt></p> <p><CdtrAcct> ▶ <Id>FR98765CC01</Id></p> <p><FnlAgt> ▶ <BIC>CREFRPPXXX</BIC></p> <p><RmInf> ▶ <Unstrd>HKL1234</Unstrd></p>	<p>BIC of mirror account</p> <p>Unique reference number of transaction (assigned by sender)</p> <p>Related reference</p> <p>Amount to be debited/credited</p> <p>Third party's/final beneficiary's account to be credited (creditor)</p> <p>RTGS account to be credited in SSP - sender of MT 202</p> <p>Information from ordering institution to final beneficiary (RemittanceInformation)</p>
② MT 202 from PM to Settlement Bank	<p>S: TRGTXEPMASI</p> <p>R: CREFRPPXXX</p> <p>20: KKM1234</p> <p>21: XYZ456</p> <p>32A: 12345678.90</p> <p>52a: /ABC1234 BANKFRPPXXX</p> <p>58a: ▶ /FR98765CC01 ▶ /CREFRPPXXX</p> <p>72: (line 1)/INS/ BBBGBRAAXX (other lines) /ASINF/ HKL1234</p>	<p>TRGTXEPMASI</p> <p>BIC of RTGS account credited in SSP (FinalAgent)</p> <p>TRN of this message (assigned by ASI)</p> <p>Related reference (EndToEndIdentification) of initial ATransferInitiation</p> <p>Value date, currency code and amount to be credited</p> <p>Third party's/ordering institution's account debited (debtor), if filled</p> <p>▶ Third party's/final beneficiary's account credited (creditor), if filled</p> <p>▶ else: BIC of RTGS account to be credited in SSP (FinalAgent)</p> <p>BIC of mirror account (FirstAgent)</p> <p>Information from ordering institution to final beneficiary, if filled (RemittanceInformation)</p>
⑤ ASInitiationStatus from PM to Ancillary System	<p><Grpld>ABCDE1234</Grpld></p>	<p>Unique ID of initial ATransferInitiation</p>

2 Flow of payments/transactions

2.4 AS transactions

2.4.1 Liquidity transfer

2.4.1.2 Debit the settlement bank account and credit the mirror account

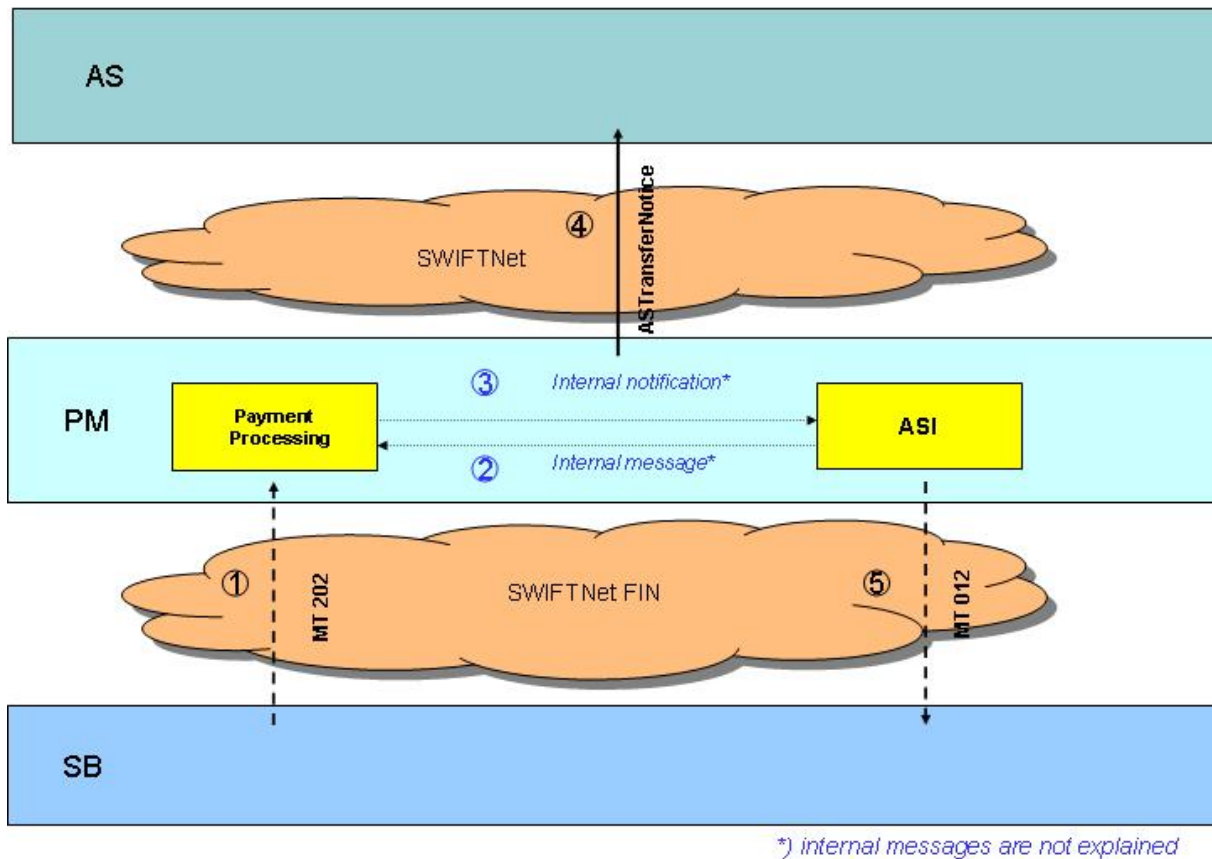

Message	Tag/field of message	Field entry
① MT 202 from Settlement Bank to PM	S: BBBBGRAAXX	BIC of RTGS account debited in SSP (FirstAgent)
	R: TRGTXEPMASI	TRGTXEPMASI
	20: JJL5186	TRN of this message (assigned by sender)
	21: XYZ456	Related reference (EndToEndIdentification)
	32A: 12345678.90	Amount to be debited/credited

2 Flow of payments/transactions

2.4 AS transactions

2.4.1 Liquidity transfer

	<p>52d: ▶ Name of ordering inst.</p> <p>52a: ▶ BANKFRPPXXX or /ABC1234 BANKFRPPXXX</p> <p>57a: CREFRPPXXX</p> <p>58a: ▶ Name of final beneficiary</p> <p>58a: ▶ APNADEFFXXX or /FR98765CC01 APNADEFFXXX</p> <p>72: /ASINF/ HKL1234</p>	<p>▶ Third party's/ordering institution's name to be debited (debtor), if filled</p> <p>▶ Third party's/ordering institution's BIC or account to be debited (debtor), if filled</p> <p>BIC of the mirror account of the AS</p> <p>▶ Third party's/final beneficiary's name to be credited (creditor), if filled</p> <p>▶ Third party's/final beneficiary's BIC or account to be credited (creditor), if filled</p> <p>Information from ordering institution to final beneficiary, if filled (Remittance Information)</p>
④ ATransferNotice from PM to Ancillary System	<p><Grpld>ABCDE1234</Grpld></p> <p><Dbtr></p> <p>▶ <Nm>Name of ordering inst.</Nm></p> <p>▶ <BIC>BANKFRPPXXX<\BIC></p> <p><DbtrAcct></p> <p>▶ <Id>ABC1234</Id></p> <p><FrstAgt></p> <p>▶ <BIC>BBBGBRAAXX</BIC></p> <p><PmtTx></p> <p>▶ <PmtId></p> <p>▶ <InstrId>ABC1234</InstrId></p> <p>▶ <EndToEndId>XYZ456</EndToEndId></p> <p>▶ <InstAmt>12345678.90</InstAmt></p> <p>></p> <p><Cdtr></p> <p>▶ <Nm>Name of final beneficiary</Nm></p> <p>▶ <BIC>APNADEFFXXX<\BIC></p> <p><CdtrAcct></p> <p>▶ <Id>FR98765CC01</Id></p>	<p>Unique ID for the file (assigned by ASI)</p> <p>▶ Third party/ordering institution to be debited (debtor) - field 52 of initial MT 202 in case of option D</p> <p>▶ BIC of third party/ordering institution to be debited (debtor) - field 52 of initial MT 202 in case of option A</p> <p>Third party's/ordering institution's account to be debited (debtor) - field 52 of MT 202 in case of option A</p> <p>RTGS account to be debited in SSP (FirstAgent) – sender of MT 202</p> <p>Unique reference number of transaction (assigned by sender) - field 20 of initial MT 202</p> <p>Related reference - field 21 of initial MT 202</p> <p>Amount</p> <p>▶ Third party/final beneficiary to be credited (creditor) - field 58 of initial MT 202 in case of option D</p> <p>▶ BIC of third party/final beneficiary to be credited (creditor) - field 58 of initial MT 202 in case of option A</p> <p>Third party's/final beneficiary's account to be credited (creditor) - field 58 of initial MT 202, party identifier from field 58 in case of option A</p>

2 Flow of payments/transactions

2.4 AS transactions

2.4.1 Liquidity transfer

	<FnIAgt> ► <BIC> CREFRPPXXX </BIC> <RmInf> ► <Unstrd> HKL1234 </Unstrd>	BIC of mirror account of AS Information from ordering institution to final beneficiary (RemittanceInformation), if indicated in field 72 /ASINF/ of initial MT 202 ①
⑤ MT 012 (<i>optional</i>) from PM to Settlement Bank	114 line 4/JJL5186	TRN of initial MT 202 ①

2 Flow of payments/transactions

2.4 AS transactions

2.4.2 Real - time – settlement

2.4.2 Real - time – settlement

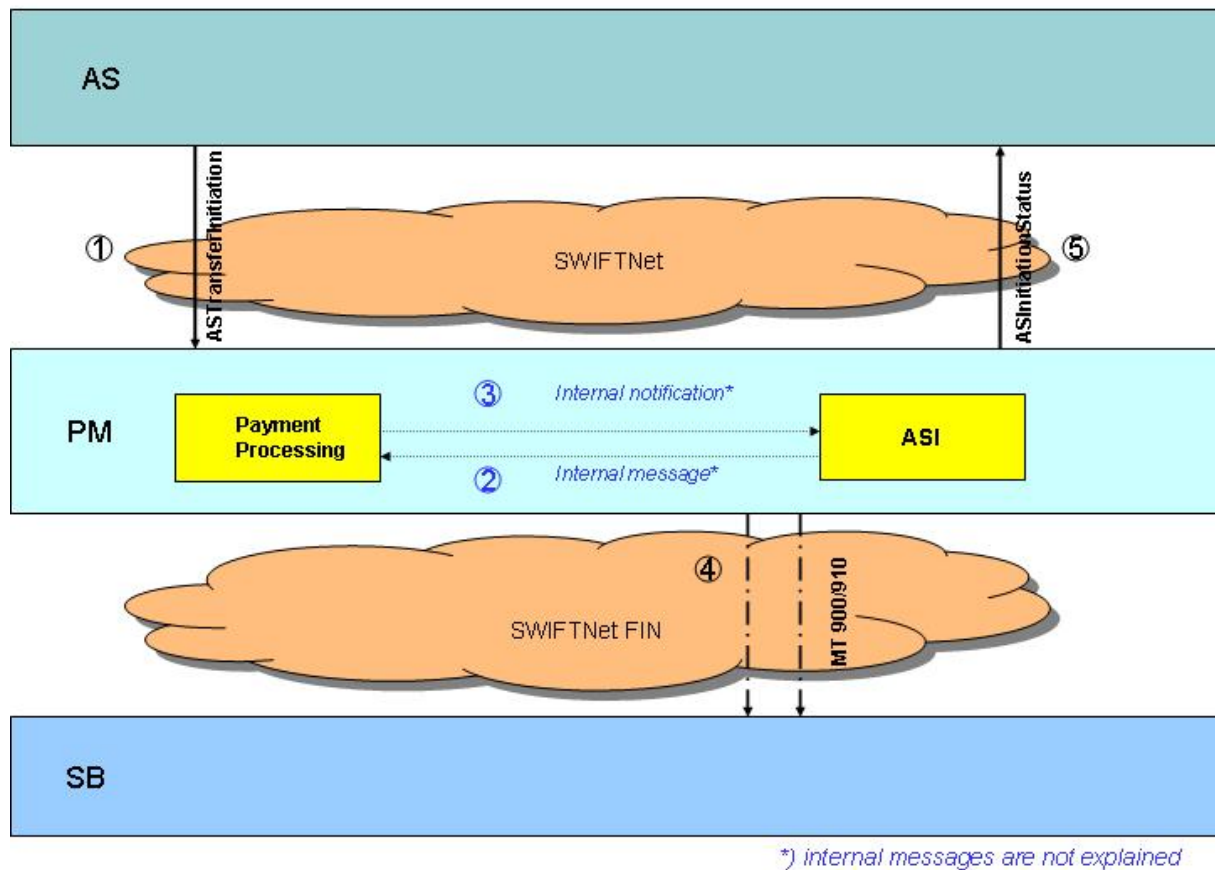

Message	Tag/field of message	Field entry
① ASTransferInitiation from Ancillary System to PM	<Grpld> ABCDE1234 </Grpld>	Unique ID for the file (assigned by AS)
	<SchldTm> ▶ <FrTm> 12:00:00 </FrTm>	Start of Settlement Period (end of Information Period)
	<InitgPty> ▶ <BIC> INNDNL2UXXX </BIC>	BIC of AS if CB sends this message on behalf of the AS – InitiatingParty
	<DbtrAcct> ▶ <DmstAcct> ▶ <ld> ABC1234 </ld>	Third party's/ordering institution's account to be debited

2 Flow of payments/transactions

2.4 AS transactions

2.4.2 Real - time – settlement

	<p><FrstAgt> ▶ <BIC>BBBBGRAAXX</BIC></p> <p><PmtTx> ▶ <PmtId> <InstrId>ABC1234</InstrId> ▶ <EndToEndId>XYZ456</EndToEndId></p> <p>▶ <InstAmt>12345678.90</InstAmt></p> <p><CdtrAcct> ▶ <DmstAcct> ▶ <Id>FR98765CC01</Id></p> <p><FnlAgt> ▶ <BIC>CREDFRPPXXX</BIC></p> <p><Rmlnf> ▶ <Unstrd>HKL1234</Unstrd></p>	<p>RTGS account to be debited in SSP</p> <p>Unique reference number of transaction (assigned by AS)</p> <p>Related reference</p> <p>Amount to be debited/credited</p> <p>Third party's/final beneficiary's account to be credited</p> <p>RTGS account to be credited in SSP</p> <p>Information from ordering institution to final beneficiary</p>
④ MT 900 (optional) from PM to Settlement Bank (debtor)	S: TRGTXEPMASI	TRGTXEPMASI
	R: BBBBGRAAXX	BIC of debited RTGS account (First Agent)
	20: UVW6789	TRN of this message
	21: XYZ456	Related reference (EndToEndIdentification) of initial (ASTransferInitiation)
	25: GR12345678910111213141516171819202	Debited RTGS account
	32A: 12345678.90	Amount to be debited/credited
	52a: ▶ INNDNL2UXXX ▶ CASIDFFXXX	▶ BIC of InitiatingParty (if filled) ▶ else: BIC of sender of initial ASTransferInitiation
72: ▶ /ASDEBT/ ++ABC1234 ▶ /ASINF/ HKL1234	▶ Debtor from ① ▶ Information from ordering institution to final beneficiary (RemittanceInformation)	
④ MT 910 (optional) from PM to Settlement Bank (creditor)	S: TRGTXEPMASI	TRGTXEPMASI
	R: CREDFRPPXXX	BIC of credited RTGS account (Final Agent)
	20: RTH3378	TRN of this message
	21: XYZ456	Related reference (EndToEndIdentification) of initial ASTransferInitiation
	25: FR12345678910111213141516171819202	Credited RTGS account
32A: 12345678.90	Amount to be debited/credited	

2 Flow of payments/transactions

2.4 AS transactions

2.4.2 Real - time – settlement

	52a: ▶ INNDNL2UXXX ▶ CASIDEFFXXX	▶ BIC of InitiatingParty (if filled) ▶ else: BIC of sender of initial ASTransferInitiation
⑤ ASInitiationStatus from PM to Ancillary System	72: ▶ /ASCRED/ ++FR98765CC01 ▶ /ASINF/ HKL1234	▶ Creditor from ① ▶ Information from ordering institution to final beneficiary (RemittanceInformation)
	<GrpId> ABCDE1234 </GrpId>	Unique ID of initial ASTransferInitiation

2 Flow of payments/transactions

2.4 AS transactions

2.4.3 Bilateral settlement

2.4.3 Bilateral settlement

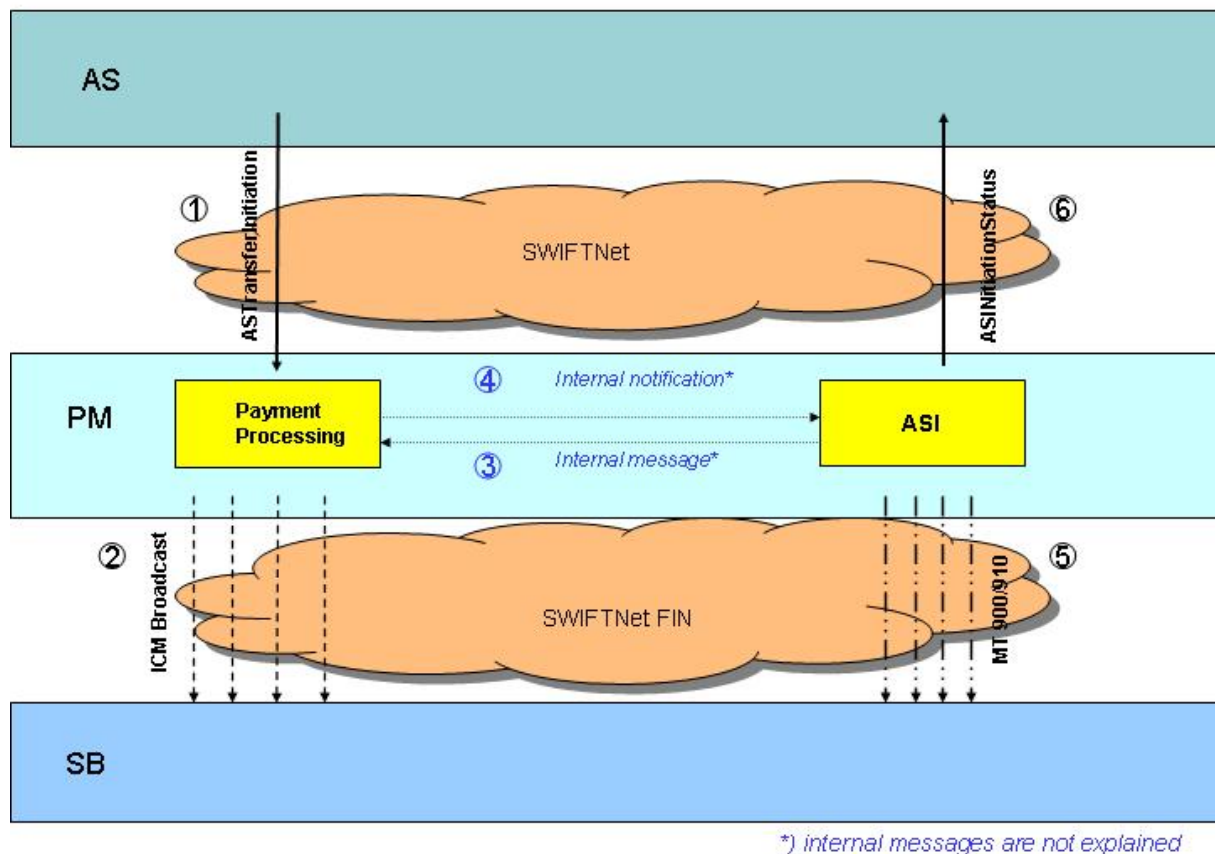

Message	Tag/field of message	Field entry
① ASTransferInitiation from Ancillary System to PM	<Grpld> ABCD1234 </Grpld>	Unique ID for the file (assigned by AS)
	<SchldTm> ▶ <FrTm> 12:00:00 </FrTm>	Start of Settlement Period (end of Information Period)
	<InitgPty> ▶ <BIC> INNDNL2UXXX </BIC>	BIC of AS if CB sends this message on its behalf – InitiatingParty
	<DbtrAcct> ▶ <DmstAcct> ▶ <Id> ABC1234 </Id>	Third party's/ordering institution's account to be debited

2 Flow of payments/transactions

2.4 AS transactions

2.4.3 Bilateral settlement

	<p><FrstAgt> ▶ <BIC>BBBBGRAAXX</BIC></p> <p><PmtTx> ▶ <PmtId> <InstrId>ABC1234</InstrId></p> <p>▶ <EndToEndId>XYZ456</EndToEndId></p> <p>▶ <InstAmt>12345678.90</InstAmt></p> <p><CdtrAcct> ▶ <DmstAcct> ▶ <Id>FR98765CC01</Id></p> <p><FnlAgt> ▶ <BIC>CREDFRPPXXX</BIC></p> <p><Rmlnf> ▶ <Unstrd>HKL1234</Unstrd></p>	<p>RTGS account to be debited in SSP</p> <p>Unique reference number of transaction (assigned by AS)</p> <p>Related reference</p> <p>Amount to be debited/credited</p> <p>Third party's/final beneficiary's account to be credited</p> <p>RTGS account to be credited in SSP</p> <p>Information from ordering institution to final beneficiary</p>
② ICM Broadcast (information on start of Information Period)	<p>[BIC of AS] CASIDFFXXX</p> <p>[InstructionIdentification] ABC1234</p> <p>[GroupIdentification] ABCD1234</p> <p>[FromTime] 12:00:00</p>	<p>BIC of pertaining AS</p> <p>InstrId of related transaction</p> <p>Unique ID of ASTransferInitiation</p> <p>Start of Settlement Period (end of Information Period)</p>
⑤ MT 900 (optional) from PM to Settlement Bank (debtor)	<p>S: TRGTXEPMASI</p> <p>R: BBBBGRAAXX</p> <p>20: WSW1234</p> <p>21: XYZ456</p> <p>25: GR12345678910111213141516171819202</p> <p>32A: 12345678.90</p> <p>52a: ▶ INNDNL2UXXX ▶ CASIDFFXXX</p> <p>72: ▶ /ASDEBT/++ABC1234 ▶ /ASINF/ HKL1234</p>	<p>TRGTXEPMASI</p> <p>BIC of debited RTGS account (First Agent)</p> <p>TRN of this message</p> <p>Related reference (EndToEndIdentification) of initial ASTransferInitiation</p> <p>Debited RTGS account</p> <p>Amount to be debited/credited</p> <p>▶ BIC of InitiatingParty, if filled</p> <p>▶ else: BIC of sender of ASTransferInitiation</p> <p>▶ Debtor from ①</p> <p>▶ Information from ordering institution to final beneficiary (RemittanceInformation)</p>
⑤ MT 910 (optional) from PM to Settlement Bank (creditor)	<p>S: TRGTXEPMASI</p> <p>R: CREDFRPPXXX</p> <p>20: BNM1234</p>	<p>TRGTXEPMASI</p> <p>BIC of credited RTGS account (Final Agent)</p> <p>TRN of this message</p>

2 Flow of payments/transactions

2.4 AS transactions

2.4.3 Bilateral settlement

	21: XYZ456	Related reference (EndToEndIdentification) of initial ASTransferInitiation
	25: FR12345678910111213141516171819202	Credited RTGS account
	32A: 12345678.90	Amount to be debited/credited
	52a: ▶ INNDNL2UXXX ▶ CASIDEFFXXX	▶ BIC of InitiatingParty, if filled ▶ else: BIC of sender of ASTransferInitiation
	72: ▶ /ASCRED/++FR98765CC01 ▶ /ASINF/ HKL1234	▶ Creditor from ① ▶ Information from ordering institution to final beneficiary (RemittanceInformation)
⑥ ASInitiationStatus from PM to Ancillary System	<GrpId> ABCDE1234 </GrpId>	Unique ID of initial ASTransferInitiation

2 Flow of payments/transactions

2.4 AS transactions

2.4.4 Standard multilateral settlement

2.4.4 Standard multilateral settlement

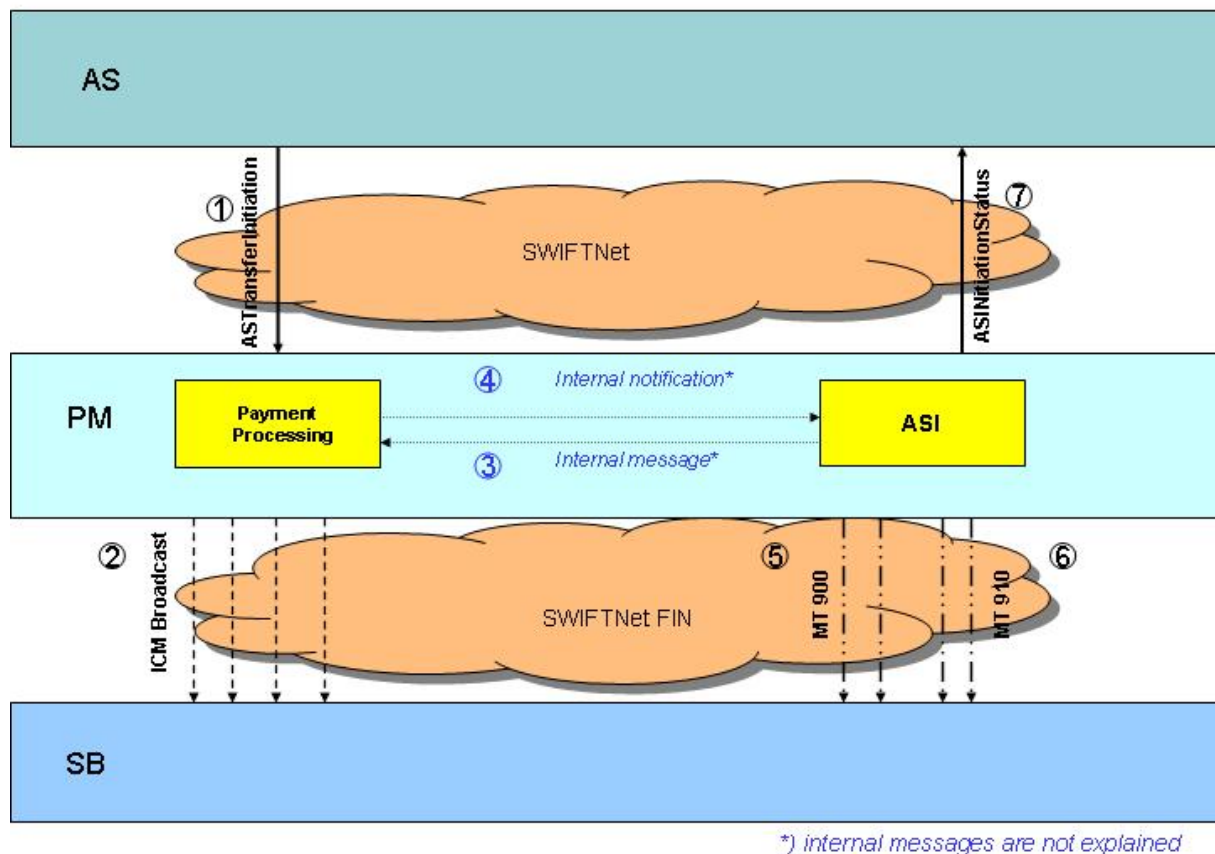

Message	Tag/field of message	Field entry
① ASTransferInitiation from Ancillary System to PM	<Grpld> ABCD1234 </Grpld>	Unique ID for the file (assigned by sender)
	<SchldTm> ▶ <FrTm> 12:00:00 </FrTm>	Start of Settlement Period (end of Information Period)
	<InitgPty> ▶ <BIC> INNDNL2UXXX </BIC>	BIC of AS if CB sends this message on its behalf – InitiatingParty
	<DbtrAcct> ▶ <DmstAcct> ▶ <ld> ABC1234 </ld>	Third party's/ordering institution's account to be debited

2 Flow of payments/transactions

2.4 AS transactions

2.4.4 Standard multilateral settlement

	<p><FrstAgt> ▶ <BIC>BBBBGRAAXX</BIC></p> <p><PmtTx> ▶ <PmtId> <InstrId>ABC1234</InstrId></p> <p>▶ <EndToEndId>XYZ456</EndToEndId></p> <p>▶ <InstAmt>12345678.90</InstAmt></p> <p><CdtrAcct> ▶ <DmstAcct> ▶ <Id>FR98765CC01</Id></p> <p><FnlAgt> ▶ <BIC>TECHFRPPXX</BIC></p> <p><RmInf> ▶ <Unstrd>HKL1234</Unstrd></p>	<p>RTGS account to be debited in SSP</p> <p>Unique reference number of transaction (assigned by sender)</p> <p>Related reference</p> <p>Amount to be debited/credited</p> <p>Third party's/final beneficiary's account to be credited</p> <p>Technical account to be credited in SSP – the cross entry from Technical Account to receiving sub account has to be done in a repetitive payment instruction within this AST</p> <p>Information from ordering institution to final beneficiary</p>
② ICM Broadcast (information on start of Information Period)	<p>[BIC of AS] CASIDFFXXX</p> <p>[GroupIdentification] ABC1234</p> <p>[FromTime] 12:00:00</p>	<p>BIC of pertaining AS</p> <p>Unique ID of ASTransferInitiation</p> <p>Start of Settlement Period (end of Information Period)</p>
⑤ MT 900 (optional) from PM to Settlement Bank (debtor)	<p>S: TRGTXEPMASI</p> <p>R: BBBBGRAAXX</p> <p>20: BVC68125</p> <p>21: XYZ456</p> <p>25: GR12345678910111213141516171819202</p> <p>32A: 12345678.90</p> <p>52a: ▶ INNDNL2UXXX ▶ CASIDFFXXX</p> <p>72: ▶ /ASDEBT/++ABC1234 ▶ /ASINF/ HKL1234</p>	<p>TRGTXEPMASI</p> <p>BIC of debited RTGS account (First Agent)</p> <p>TRN of this message</p> <p>Related reference (EndToEndIdentification) of initial ASTransferInitiation</p> <p>Debited RTGS account</p> <p>Amount to be debited/credited</p> <p>▶ BIC of InitiatingParty, (if filled) ▶ else: BIC of sender of ASTransferInitiation</p> <p>▶ Debtor from ① ▶ Information from ordering institution to final beneficiary (RemittanceInformation)</p>
⑥ MT 910 (optional) from PM	<p>S: TRGTXEPMASI</p> <p>R: CREFRPPXX</p>	<p>TRGTXEPMASI</p> <p>BIC of credited RTGS account (Final Agent)</p>

2 Flow of payments/transactions

2.4 AS transactions

2.4.4 Standard multilateral settlement

to Settlement Bank (creditor)	20: OPK6582	TRN of this message
	21: XYZ456	Related reference (EndToEndIdentification) of initial ASTransferInitiation
	25: FR123456789101112131415161 71819202	Credited RTGS account
	32A: 12345678.90	Amount to be debited/credited
	52a: ► INNDNL2UXXX ► CASIDFFFXXX	► BIC of InitiatingParty, (if filled) ► else: BIC of sender of ASTransferInitiation
	72: ► /ASCRED/++FR98765CC01 ► /ASINF/ HKL1234	► Creditor from ① ► Information from ordering institution to final beneficiary (RemittanceInformation)
⑦ ASInitiationStatus from PM to Ancillary System	<GrpId> ABCD1234 </GrpId>	Unique ID of initial ASTransferInitiation

2 Flow of payments/transactions

2.4 AS transactions

2.4.5 Simultaneous multilateral settlement

2.4.5 Simultaneous multilateral settlement

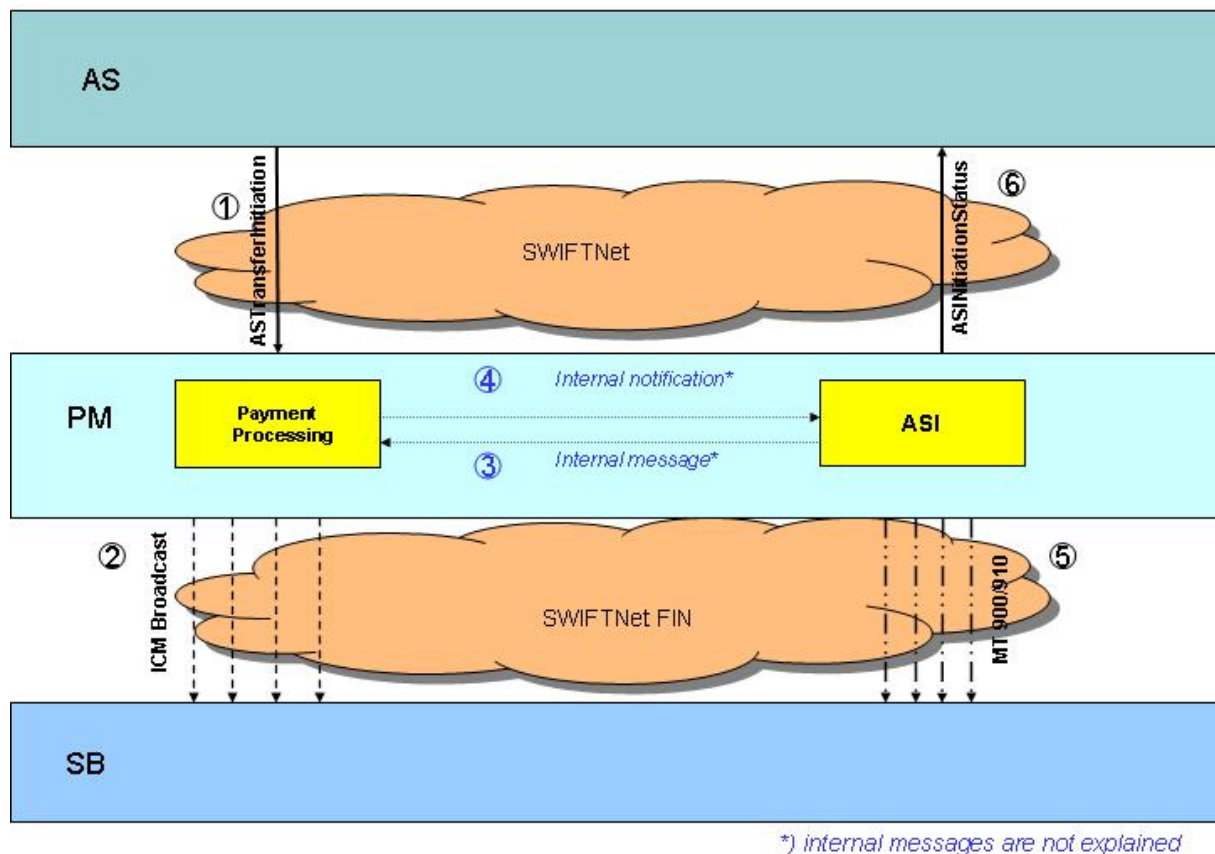

*) internal messages are not explained

Message	Tag/field of message	Field entry
① ASTransferInitiation from Ancillary System to PM	<Grpld>ABCDE1234</Grpld>	Unique ID for the file (assigned by sender)
	<SchldTm> ▶ <FrTm>12:00:00</FrTm>	Start of Settlement Period (end of Information Period)
	<InitgPty> ▶ <BIC>INNDNL2UXXX</BIC>	BIC of AS if CB sends this message on its behalf – InitiatingParty
	<DbtrAcct> ▶ <DmstAcct> ▶ <Id>ABC1234</Id>	Third party's/ordering institution's account to be debited
	<FrstAgt> ▶ <BIC>BBBBGRAAXX</BIC>	RTGS account to be debited in SSP

2 Flow of payments/transactions

2.4 AS transactions

2.4.5 Simultaneous multilateral settlement

	<PmtTx> ▶ <PmtId> <InstrId> ABC1234 </InstrId> ▶ <EndToEndId> XYZ456 </EndToEndId> ▶ <InstAmt> 12345678.90 </InstAmt>	Unique reference number of transaction (assigned by sender) - field 20 of MT 202 Related reference Amount
	<CdtrAcct> ▶ <DmstAcct> ▶ <Id> FR98765CC01 </Id>	Third party's/final beneficiary's account to be credited
	<FnlAgt> ▶ <BIC> TECHFRPPXXX </BIC>	Technical account to be credited in SSP
	<RmInf> ▶ <Unstrd> HKL1234 </Unstrd>	Information from ordering institution to final beneficiary
② ICM Broadcast (information on start of Information Period)	[BIC of AS] CASIDEFFXXX	BIC of pertaining AS
	[GroupIdentification] ABCDE1234	Unique ID of ATransferInitiation
	[FromTime] 12:00:00	Start of Settlement Period (end of Information Period)
	[InstructionIdentification] ABC1234	InstrId of related transaction
	[EndToEndIdentification] XYZ456	Related reference of pertaining transaction
	[Amount] 12345678.90	Instructed Amount of related transaction
	[FirstAgent] BBBGBRAAXX	RTGS account to be debited
	[FinalAgent] CREDFRPPXXX	RTGS account to be credited
[RemittanceInformation] HKL1234	Information from ordering institution to final beneficiary	
⑤ MT 900 (optional) from PM to Settlement Bank (debtor)	S: TRGTXEPMASI	TRGTXEPMASI
	R: BBBGBRAAXX	BIC of debited RTGS account (First Agent)
	20: BBV8224	TRN of this message
	21: XYZ456	Related reference (EndToEndIdentification) of initial ATransferInitiation
	25: GR12345678910111213141516171819202	Debited RTGS account
	32A: 12345678.90	Amount to be debited/credited
	52a: ▶ INNDNL2UXXX ▶ CASIDEFFXXX	▶ BIC of InitiatingParty, (if filled) ▶ else: BIC of sender of ATransferInitiation

2 Flow of payments/transactions

2.4 AS transactions

2.4.5 Simultaneous multilateral settlement

	72: ▶ /ASDEBT/++ABC1234 ▶ /ASINF/ HKL1234	▶ Debtor from ① ▶ Information from ordering institution to final beneficiary (RemittanceInformation)
⑤ MT 910 (optional) from PM to Settlement Bank (creditor)	S: TRGTXEPMASI	TRGTXEPMASI
	R: CREFRPPXXX	BIC of credited RTGS account (Final Agent)
	20: SPH5814	TRN of this message
	21: XYZ456	Related reference (EndToEndIdentification) of initial ASTransferInitiation
	25: FR12345678910111213141516171819202	Credited RTGS account
	32A: 12345678.90	Amount to be debited/credited
	52a: ▶ INNDNL2UXXX ▶ CASIDEFFXXX	▶ BIC of InitiatingParty, (if filled) ▶ else: BIC of sender of ASTransferInitiation
72: ▶ /ASCRED/++FR98765CC01 ▶ /ASINF/ HKL1234	▶ Creditor from ① ▶ Information from ordering institution to final beneficiary (RemittanceInformation)	
⑥ ASInitiationStatus from PM to Ancillary System	<Grpld>ABCDE1234</Grpld>	Unique ID of initial ASTransferInitiation

2 Flow of payments/transactions

2.4 AS transactions

2.4.6 Settlement on dedicated liquidity account

2.4.6 Settlement on dedicated liquidity account

2.4.6.1 Interfaced model

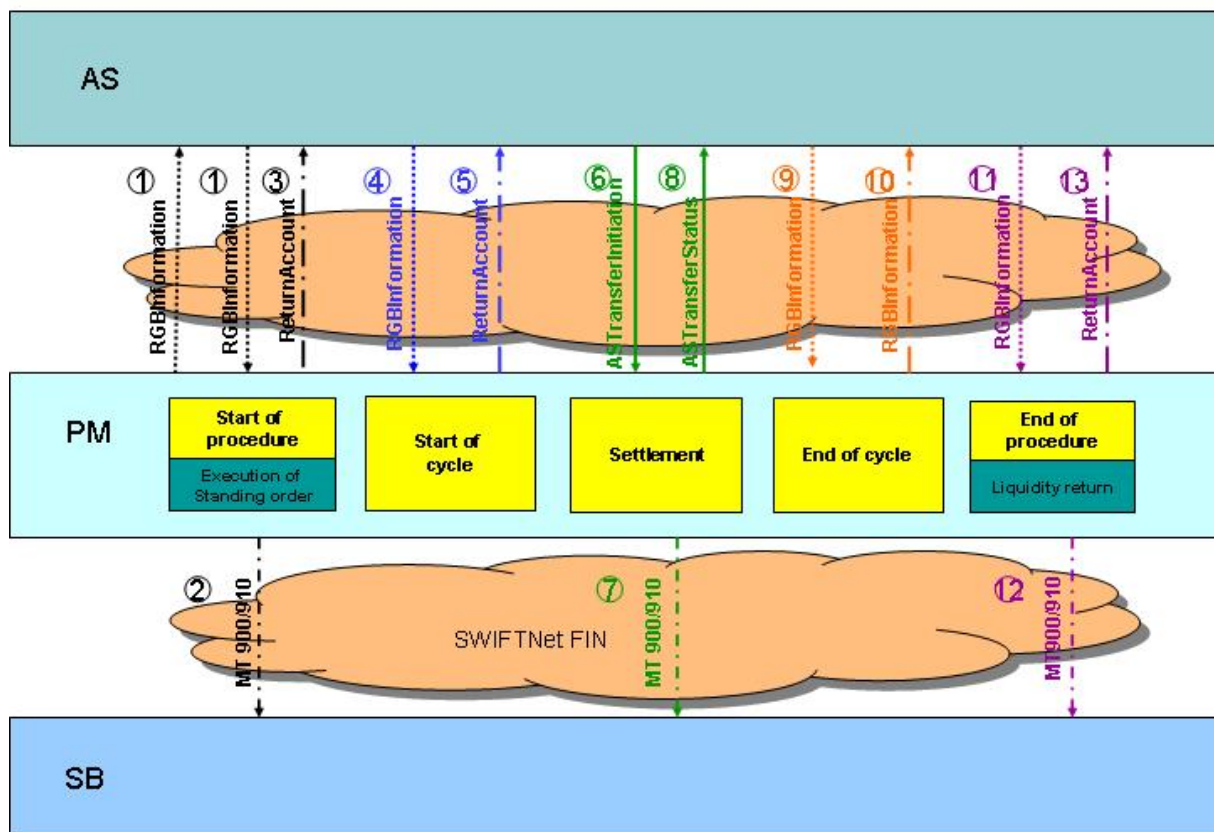

Message	Tag/field of message	Field entry
① ReturnGeneral BusinessInformation	<MsgId> ▶ <Id> ABC1234 </Id>	Unique ID for the file (assigned by ASI)
	<BizInfRef> CDE123 </BizInfRef>	Unique ID of general business information system (assigned by ASI)
	<Sbjt> OVN/DAY-PROC-OPEN </Sbjt>	Subject of message
② MT 900 (optional)	S: TRGTXEPMASI	TRGTXEPMASI
	R: BBBBGRAXXX	BIC of debited RTGS account

2 Flow of payments/transactions

2.4 AS transactions

2.4.6 Settlement on dedicated liquidity account

from ASI to Settlement Bank (debtor)	20: WTR4736	TRN of this message
	21: XYZ456	Internal SSP reference
	25: GR1234567891011121314151617 1819202	Debited RTGS account
	32A: 1234.56	Amount to be debited/credited
	52a: BBBBGRAAXX	BIC of Settlement Bank
② MT 910 (<i>optional</i>) from ASI to Settlement Bank (creditor)	S: TRGTXEPMASI	TRGTXEPMASI
	R: BBBBGRAAXX	BIC of sub-account owner credited
	20: DFG8456	TRN of this message
	21: XYZ456	Internal SSP reference
	25: GR9999ABC01	Credited sub-account
	32A: 1234.56	Amount to be debited/credited
	52a: BBBBGRAAXX	BIC of Settlement Bank
	72: ▶ /ASINF/ HKL1234	▶ Information from ordering institution to final beneficiary (RemittanceInformation)
③ ReturnAccount from ASI to Ancillary System	<Msgld> ▶ <ld> GHJ6543 </ld>	Unique ID for the file (assigned by ASI)
	<DmstAcct> ▶ <ld> GR9999ABC01 </ld>	Account number of sub-account
	<AcctOwnc> BBBBGRAAXX </ AcctOwnc>	BIC of Settlement Bank (sub-account owner)
	<MulBal> ▶ <Amt> 1234.56 </Amt> ▶ <Tp> BOOK </Tp>	Amount on sub-account
④ ReturnGeneral BusinessInformation from Ancillary System to ASI	<Msgld> ▶ <ld> KLM5678 </ld>	Unique ID for the file (assigned by AS)
	<BizInfRef> FGH567 </BizInfRef>	Unique ID of general business in- formation system (assigned by AS)
	<Sbjt> OVN/DAY-CYCL-OPEN </Sbjt>	Subject of message
⑤ ReturnAccount from ASI to Ancillary System	<Msgld> ▶ <ld> NOP8912 </ld>	Unique ID for the file (assigned by ASI)
	<DmstAcct> ▶ <ld> GR9999ABC01 </ld>	Account number of sub-account
	<AcctOwnc> BBBBGRAAXX </AcctOwnc>	BIC of Settlement Bank (sub-account owner)

2 Flow of payments/transactions

2.4 AS transactions

2.4.6 Settlement on dedicated liquidity account

	<p><MulBal> ▶ <Amt>1234.56</Amt> ▶ <Tp>BOOK</Tp></p>	Amount on sub-account
⑥ AS TransferInitiation from Ancillary System to ASI	<Grpld> ABCDE1234 </Grpld>	Unique ID for the file (assigned by sender)
	<p><Dbtr> ▶ <Nm>ABC1234</Nm> ▶ <FI> ▶ <BIC>AAAAGRPPXXX</BIC></p>	<p>▶ Third party's/ordering institution's name to be debited ▶ Third party's BIC to be debited</p>
	<p><FrstAgt> ▶ <BIC>BBBGBRAAXX</BIC></p>	RTGS account to be debited in SSP
	<p><FrstAgtAcct> ▶ <DmstAcct> GR9999ABC01</DmstAcct></p>	Sub account to be debited
	<p><PmtTx> ▶ <PmtId> ▶ <InstrId>UVW1234</InstrId></p>	Unique reference number of trans-action (assigned by AS)
	▶ <EndToEndId> XYZ456 </EndToEndId>	Related reference
	<p><Amt> ▶ <InstAmt>1234.56</Amt></p>	Amount to be debited on sub-account
	<p><FnlAgt> ▶ <BIC> CASIDFFTEC </BIC></p>	RTGS account to be credited in SSP (Technical account)
	<p><Rmlnf> ▶ <Unstrd>HKL1234</Unstrd></p>	Information from ordering institution to final beneficiary
	<p><FrstAgt> ▶ <BIC> CASIDFFTEC </BIC></p>	RTGS account to be debited in SSP (Technical account)
	<p><PmtTx> ▶ <PmtId> ▶ <InstrId>UVW1235</InstrId></p>	Unique reference number of trans-action (assigned by AS)
	▶ <EndToEndId> XYZ456 </EndToEndId>	Related reference
	<p><Amt> ▶ <InstAmt>1234.56</Amt></p>	Amount to be credited on sub-account
	<p><FnlAgt> ▶ <BIC>BANKFRPPXXX</BIC></p>	BIC of sub account holder to be credited in SSP
<p><FnlAgtAcct> ▶ <DmstAcct> FR9999ABC01</DmstAcct></p>	Sub account to be credited	
<p><CdtrAcct> ▶ <DmstAcct> ▶ <Id>FR98765CC01</Id></p>	Third party's/ordering institution's account to be credited	

2 Flow of payments/transactions

2.4 AS transactions

2.4.6 Settlement on dedicated liquidity account

	<RmInf> ▶<Unstrd>HKL1234</Unstrd>	Information from ordering institution to final beneficiary
⑦ MT 900 (optional) from ASI to Settlement Bank (debtor)	S: TRGTXEPMASI	TRGTXEPMASI
	R: BBBBGRAAXX	BIC of debited RTGS account
	20: PQR7894	TRN of this message
	21: ...	Internal SSP reference
	25: GR9999ABC01	Debited sub account
	32A: 1234.56	Amount to debited
	52a: CASIDFFXXX	BIC of AS
	72: /ASDEBT/ABC1234+AAAAGRXXX	Debtor from ⑥ (Name + BIC)
⑦ MT 910 (optional) from ASI to Settlement Bank (creditor)	S: TRGTXEPMASI	TRGTXEPMASI
	R: BANKFRPPXXX	BIC of sub-account owner credited
	20: STU1234	TRN of this message
	21: ...	Internal SSP reference
	25: FR9999ABC01	Credited sub account
	32A: 1234.56	Amount to be debited/credited
	52a: CASIDFFXXX	BIC of AS
	72: /ASCRED/++ FR98765CC01	Creditor from ⑥ (DomesticAccountIdentification)
⑧ ASInitiationStatus from ASI to Ancillary System	<Grpld>ABCDE1234</Grpld>	Unique ID of initial ASTransferInitiation
⑨ ReturnGeneral BusinessInformation from Ancillary System to ASI	<Msgld> ▶ <ld>UVT1234</ld>	Unique ID for the file (assigned by AS)
	<BizInfRef>KKL568</BizInfRef>	Unique ID of general business information system (assigned by AS)
	<Sbjt>OVN/DAY-CYCL-CLOS</Sbjt>	Subject of message
⑩ ReturnGeneral BusinessInformation from ASI to Ancillary System	<Msgld> ▶ <ld>FGH1234</ld>	Unique ID for the file (assigned by ASI)
	<BizInfRef>KKL568</BizInfRef>	Copy of BusinessInformation Reference of initial ReturnGeneralBusinessInformation
	<Sbjt>LIQ-CYCL-END</Sbjt>	Subject of message

2 Flow of payments/transactions

2.4 AS transactions

2.4.6 Settlement on dedicated liquidity account

⑪ ReturnGeneral BusinessInformation from Ancillary System to ASI	<Msgld> ▶ <Id> JKL4321 </Id>	Unique ID for the file (assigned by AS)
	<BizInfRef> AAB123 </BizInfRef>	Unique ID of general business information system (assigned by AS)
	<Sbjt> OVN-PROC-CLOS </Sbjt>	Subject of message
⑫ MT 910 (optional) from ASI to Settlement Bank (creditor)	S: TRGTXEPMASI	TRGTXEPMASI
	R: BBBBGRAAXXX	BIC of credited RTGS account
	20: ZVS1396	TRN of this message
	21: AAB123	Copy of BusinessInformation Reference of initial ReturnGeneralBusinessInformation
	25: GR12345678910111213141516171819202	Credited RTGS account
	32A: 1234.56 52a: CASIDEFFXXX	Amount debited/credited BIC of AS TRGTXEPMASI if procedure is closed by SSP at end of day
⑫ MT 900 (optional) from ASI to Settlement Bank (debtor)	S: TRGTXEPMASI	TRGTXEPMASI
	R: BBBBGRAAXXX	BIC of sub-account owner debited
	20: STC1234	TRN of this message
	21: AAB123	Copy of BusinessInformation Reference of initial ReturnGeneralBusinessInformation
	25: GR9999ABC01	debited sub-account
	32A: 1234.56 52a: CASIDEFFXXX	Amount debited BIC of AS TRGTXEPMASI if procedure is closed by SSP at end of day
○ ReturnAccount from ASI to Ancillary System	<Msgld> ▶ <Id> HAH1234 </Id>	Unique ID for the file (assigned by the sender)
	<DmstAcct> ▶ <Id> GR9999ABC01 </Id>	Account number of sub-account
	<AcctOwnc> BBBBGRAAXXX </AcctOwnc>	BIC of Settlement Bank (account owner)
	<MulBal> ▶ <Amt> 1234.56 </Amt> ▶ <Tp> PYMT </Tp>	Amount which was debited on sub-account

2 Flow of payments/transactions

2.4 AS transactions

2.4.6 Settlement on dedicated liquidity account

2.4.6.1.1 Connected payment

2.4.6.1.1.1 Automatic increase of blocked liquidity – connected payment (initiated by AS)

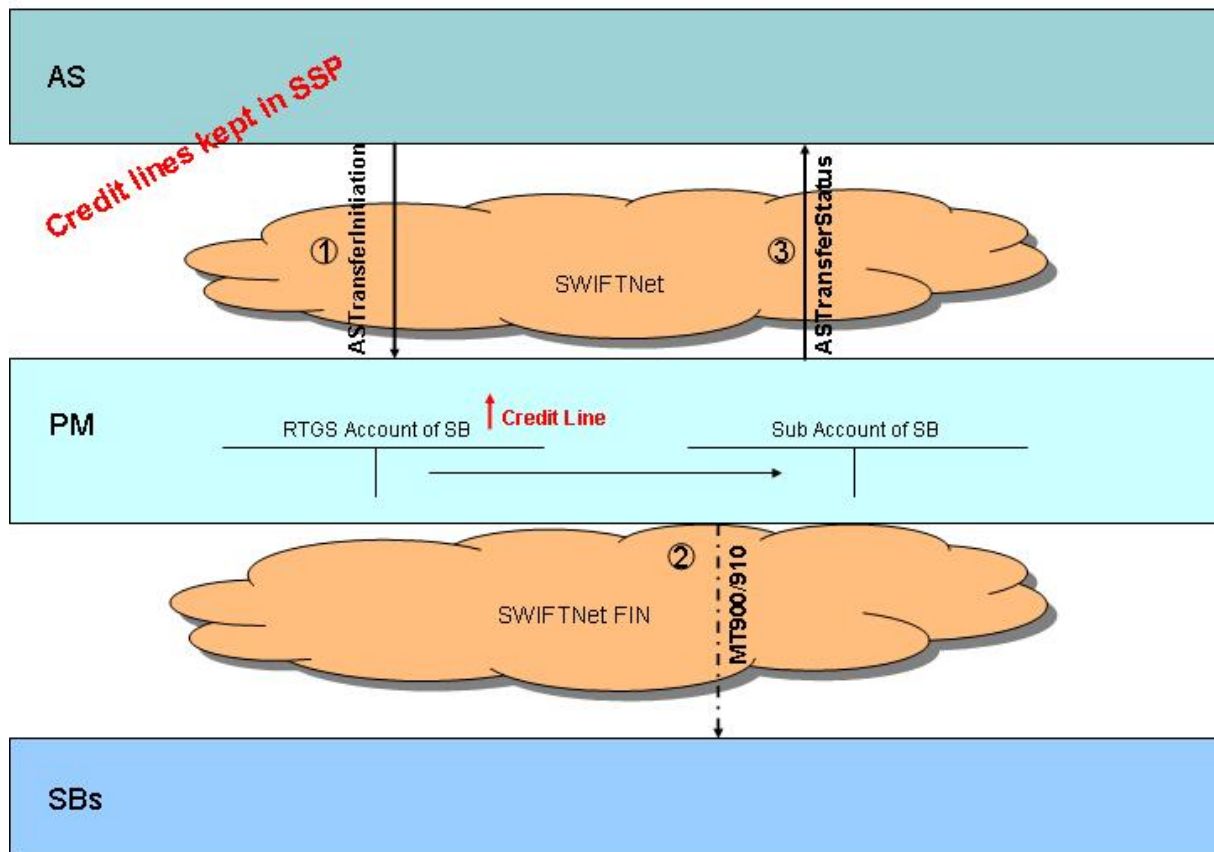

Message	Tag/field of message	Field entry
① ASTransferInitiation from Ancillary System to ASI	<Grpld> ABCDE1234 </Grpld>	Unique ID for the file (assigned by sender)
	<InitgPty> ▶ <BIC> CASIDFFFXXX </BIC>	BIC of AS
	<PmtInf> ▶ <PmtSchme> ▶ <Cd> CSP </Cd>	CSP: PaymentScheme Code for connected payments on SSP accounts

2 Flow of payments/transactions

2.4 AS transactions

2.4.6 Settlement on dedicated liquidity account

	<FrstAgt> ▶ <BIC> BBBGBRAAXX </BIC>	BIC of SB (RTGS account to be debited in SSP)
	<PmtTx> ▶ <PmtId> ▶ <InstrId> ABC1234 </InstrId> ▶ <EndToEndId> XYZ456 </EndToEndId>	Unique reference number of transaction (assigned by initiating party) Related reference
	<Amt> ▶ <InstAmt> 1,000,000.00 </Amt>	Amount
	<FnIAgt> ▶ <BIC> CREDLU2L987 </BIC>	BIC of SB (RTGS account to be credited in SSP)
	<FnIAgtAcct> ▶ <DmstAcct> ▶ <Id> LU45645AB01 </Id>	Account number of sub-account of SB
	<Rmlnf> ▶ <Unstrd> HKL1234 </Unstrd>	Information from ordering institution to final beneficiary
② MT 900 (optional) from ASI to Settlement Bank (debtor)	S: TRGTXEPMASI	TRGTXEPMASI
	R: BBBGBRAAXX	BIC of SB (debited RTGS account)
	20: GGT5698	TRN of this message
	21: XYZ456	Copy of EndToEndIdentification of initial ASTransferInitiation
	25: GR12345678910111213141516171819202	Debited RTGS account
	32A: 1,000,000.00	Amount debited
	52a: CASIDFFXXX	BIC of AS
	72: /ASDEBT/	Debtor from ① (if filled)
② MT 910 (optional) from ASI to Settlement Bank (creditor)	S: TRGTXEPMASI	TRGTXEPMASI
	R: CREDLU2L987	BIC of SB (credited sub-account)
	20: ZBD6542	TRN of this message
	21: XYZ456	Copy of EndToEndIdentification of initial ASTransferInitiation
	25: LU45645AB01	credited sub-account
	32A: 1,000,000.00	Amount credited
	52a: CASIDFFXXX	BIC of AS
	72: /ASCRED/	Creditor from ① (if filled)
③ ASInitiationStatus from ASI to Ancillary System	<GrpId> ABCDE1234 </GrpId>	Unique ID of initial ASTransferInitiation

2 Flow of payments/transactions

2.4 AS transactions

2.4.6 Settlement on dedicated liquidity account

2.4.6.1.1.2 Liquidity transfer (initiated by AS)

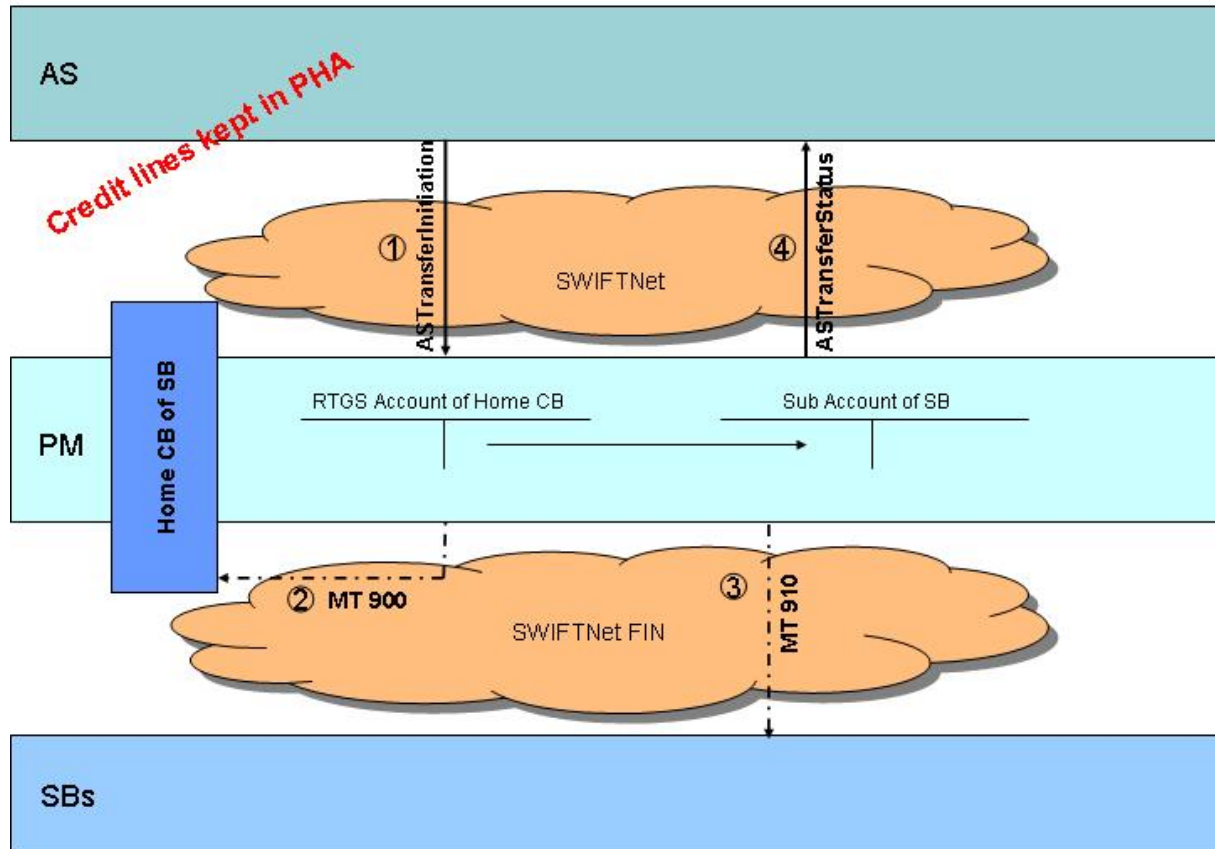

Message	Tag/field of message	Field entry
① ASTransferInitiation from Ancillary System to ASI	<Grpld> ABCDE1234 </Grpld>	Unique ID for the file (assigned by sender)
	<InitgPty> ▶ <BIC> CASIDFFXXX </BIC>	BIC of AS
	<PmtInf> ▶ <PmtSchme> ▶ <Cd> CHA </Cd>	CHA: PaymentScheme Code for increase/decrease of liquidity with credit lines managed in PHA
	<FrstAgt> ▶ <BIC> NCBBBGAAXX </BIC>	BIC of Home CB of SB (RTGS account to be debited in SSP)

2 Flow of payments/transactions

2.4 AS transactions

2.4.6 Settlement on dedicated liquidity account

	<PmtTx> ▶ <PmtId> ▶ <InstrId>ABC1234</InstrId> ▶ <EndToEndId>XYZ456</EndToEndId>	Unique reference number of transaction (assigned by initiating party) Related reference
	<Amt> ▶ <InstAmt>1,000,000.00</Amt>	Amount
	<FnIAgt> ▶ <BIC> CREDLU2L987</BIC>	BIC of SB (RTGS account to be credited in SSP)
	<FnIAgtAcct> ▶ <DmstAcct> ▶ <Id>LU45645AB01</Id>	Account number of Sub account of SB
	<Rmlnf> ▶ <Unstrd>HKL1234</Unstrd>	Information from ordering institution to final beneficiary
② MT 900 (optional) from ASI to Home CB of SB	S: TRGTXEPMASI	TRGTXEPMASI
	R: NCBBBGAAXX	BIC of Home CB of SB (debited RTGS account)
	20: GGT5698	TRN of this message
	21: XYZ456	Copy of EndToEndIdentification of initial ASTransferInitiation
	25: GR12345678910111213141516171819202	Debited RTGS account
	32A: 1,000,000.00	Amount debited
	52a: CASIDFFXXX	BIC of AS
	72: /ASDEBT/	Debtor from ① (if filled)
② MT 910 (optional) from ASI to Settlement Bank (creditor)	S: TRGTXEPMASI	TRGTXEPMASI
	R: CREDLU2L987	BIC of SB (credited sub-account)
	20: ZBD6542	TRN of this message
	21: XYZ456	Copy of EndToEndIdentification of initial ASTransferInitiation
	25: LU45645AB01	credited Sub account
	32A: 1,000,000.00	Amount credited
	52a: CASIDFFXXX	BIC of AS
	72: /ASCRED/	Creditor from ① (if filled)
③ ASInitiationStatus from ASI to Ancillary System	<GrpId>ABCDE1234</GrpId>	Unique ID of initial ASTransferInitiation

2 Flow of payments/transactions

2.4 AS transactions

2.4.6 Settlement on dedicated liquidity account

2.4.6.1.1.3 Automatic increase of blocked liquidity – connected payment. Initiated by CB or CCBM2 (on behalf of the AS)

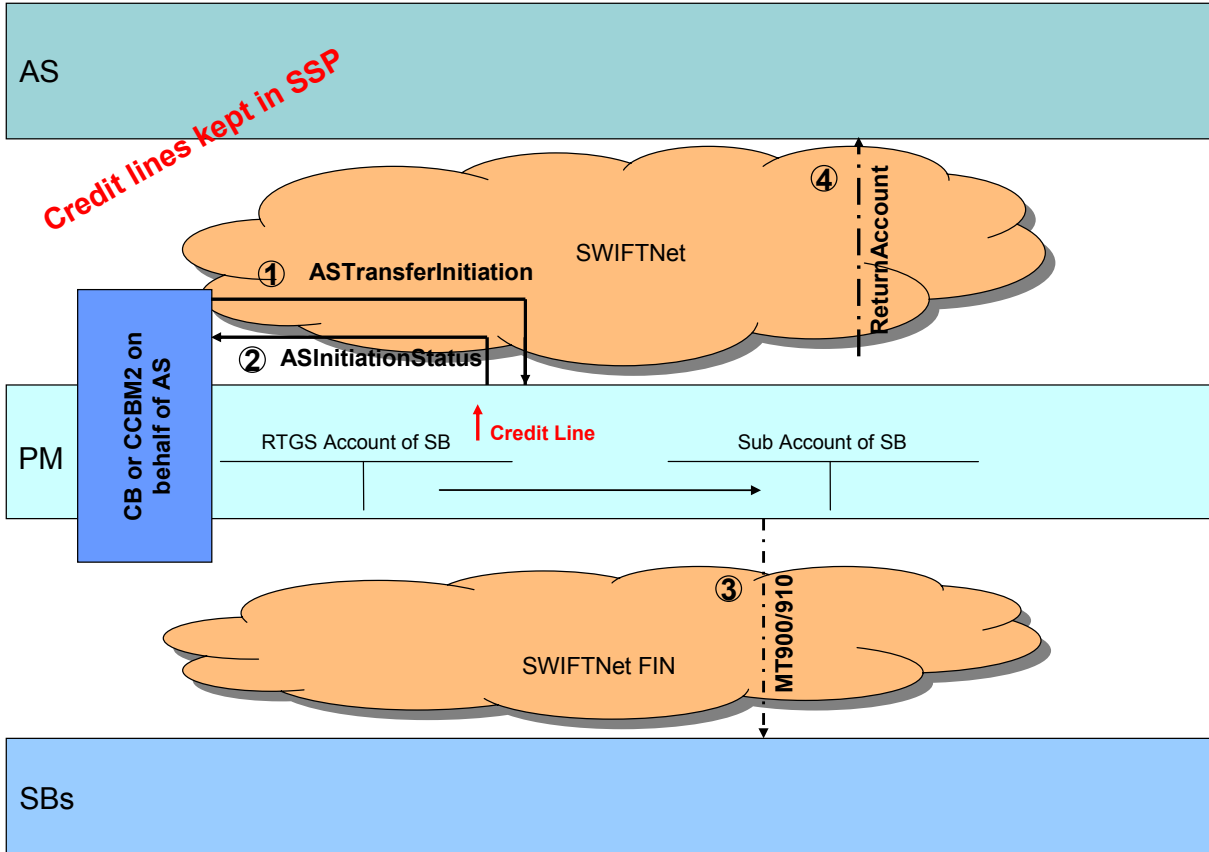

Message	Tag/field of message	Field entry
① ASInitiationStatus	<GrpId> ABCDE1234 </GrpId>	Unique ID for the file (assigned by sender)

2 Flow of payments/transactions

2.4 AS transactions

2.4.6 Settlement on dedicated liquidity account

from CB or CCBM2 to ASI on behalf of Ancillary System	<p><InitgPty> ▶ <BIC>ASBICAAAXXX</BIC></p>	<p>BIC of AS. Only filled in case a CB or CCBM2 is sending the message on behalf of an AS.</p> <p>If the sender is a CB then the Initiating Party must be filled with a BIC of an authorised AS and member of this CB.</p> <p>If the sender is CCBM2 then the initiating party must be filled with a BIC of an authorised AS with a CCBM2Flag 'Y' and the sender DN is defined for CCBM2 for the CB of the AS.</p>
	<p><PmtInf> ▶ <PmtSchme> ▶ <Cd>CSP</Cd></p>	<p>CSP: PaymentScheme Code for connected payments on SSP accounts</p>
	<p><FrstAgt> ▶ <BIC>CREDLU2L987</BIC></p>	<p>BIC of SB (RTGS account to be debited in SSP)</p>
	<p><PmtTx> ▶ <PmtId> ▶ <InstrId>ABC1234</InstrId></p>	<p>Unique reference number of transaction (assigned by initiating party)</p>
	<p>▶ <EndToEndId>XYZ456</EndToEndId></p>	<p>Related reference</p>
	<p><Amt> ▶ <InstAmt>1,000,000.00</Amt></p>	<p>Amount</p>
	<p><FnlAgt> ▶ <BIC>CREDLU2L987</BIC></p>	<p>BIC of SB (Sub account to be credited in SSP)</p>
	<p><FnlAgtAcct> ▶ <DmstAcct> ▶ <Id>LU45645AB01</Id></p>	<p>Account number of sub-account of SB</p>
<p><RmlInf> ▶ <Unstrd>HKL1234</Unstrd></p>	<p>Information from ordering institution to final beneficiary</p>	
<p>② ASInitiationStatus from ASI to Home CB of SB</p>	<p><Grpld>ABCDE1234</Grpld></p>	<p>Unique ID of initial ASTransferInitiation ①</p>
<p>③ MT 900 (optional) from ASI to Settlement Bank (debtor)</p>	<p>S: TRGTXEPMASI</p>	<p>TRGTXEPMASI</p>
	<p>R: CREDLU2L987</p>	<p>BIC of SB (debited RTGS account)</p>
	<p>20: MQR6354</p>	<p>TRN of this message</p>
	<p>21: XYZ456</p>	<p>EndtoEndIdentification field of initial ASTransferInitiation</p>

2 Flow of payments/transactions

2.4 AS transactions

2.4.6 Settlement on dedicated liquidity account

	25: GR123456789101112131415 16171819202	Debited RTGS account
	32A: 1,000,000.00	Amount debited/credited
	52a: ASBICAAAXX	Ancillary System BIC
	72: /ASDEBT/	Debtor from ① (if filled)
③ MT 910 (optional) from ASI to Settlement Bank (creditor)	S: TRGTXEPMASI	TRGTXEPMASI
	R: CREDLU2L987	BIC of SB (credited Sub account)
	20: WMZ2345	TRN of this message
	21: XYZ456	EndtoEndIdentification field of initial ASTransferInitiation ①
	25: LU45645AB01	Credited Sub account
	32A: 1,000,000.00	Amount credited
	52a: ASBICAAAXX	Ancillary System BIC
	72: /ASCRED/	Creditor from ① (if filled)
④ ReturnAccount from ASI to Ancillary System	<MsgId> ▶ <Id>EEA7895</Id>	Unique ID for the file (assigned by ASI)
	<DmstAcct> ▶ <Id>LU45645AB01</Id>	Sub account number
	<AcctOwnr>CREDLU2L987</Acct Ownr>	BIC of the SB (sub-account owner)
	<MulBal> ▶ <Amt>1,000,000.00</Amt> ▶ <Tp>PYMT</Tp>	Increase or decrease amount of operation
	<MulBal> ▶ <Amt>6,543,987.00</Amt> ▶ <Tp>BOOK</Tp>	New balance on sub-account

2 Flow of payments/transactions

2.4 AS transactions

2.4.6 Settlement on dedicated liquidity account

2.4.6.1.1.4 Liquidity transfer (initiated by CB on behalf of AS)

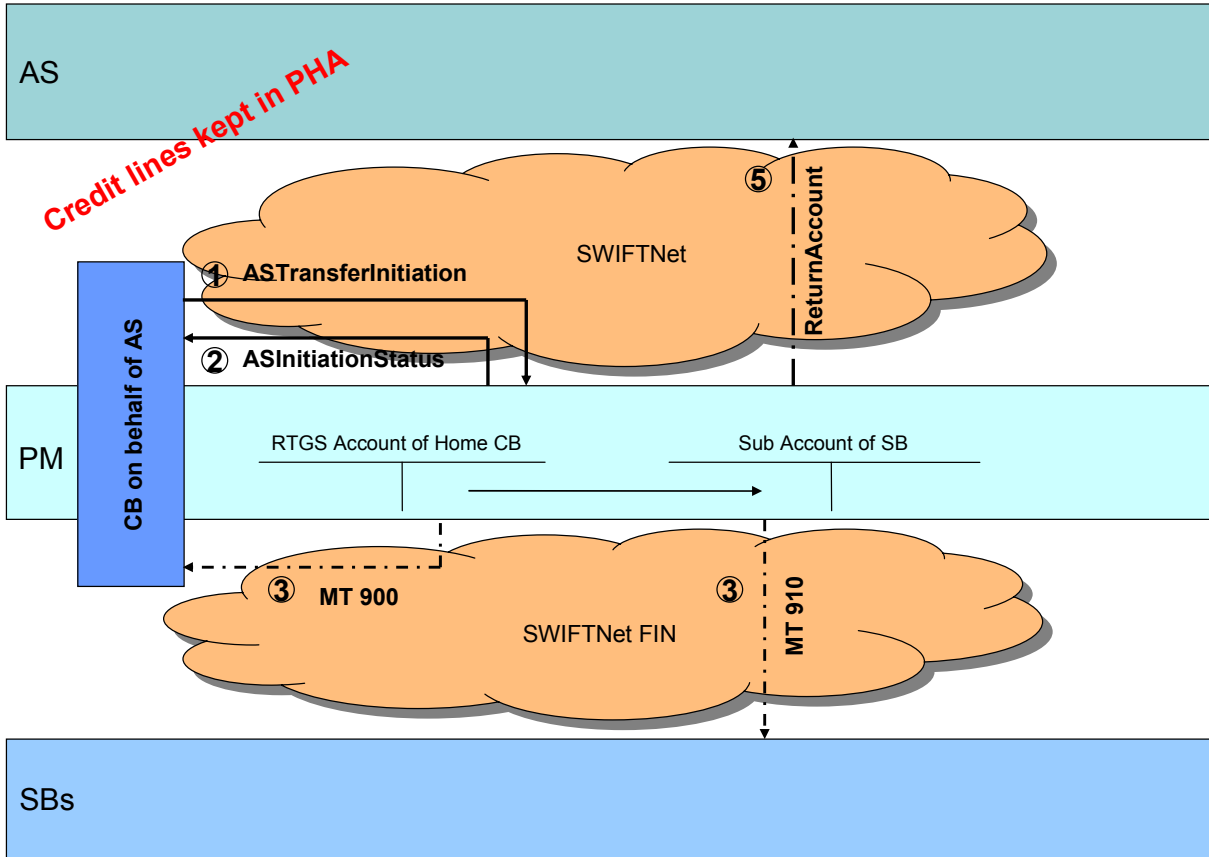

Message	Tag/field of message	Field entry
① ASTransferInitiation from CB to ASI on behalf of AS	<GrpId> ABCDE1234 </GrpId>	Unique ID for the file (assigned by sender)
	<InitgPty> ▶ <BIC> ASBICAAAXXX </BIC>	Ancillary System BIC
	<PmtInf> ▶ <PmtSchme> ▶ <Cd> CHA </Cd>	CHA: PaymentScheme Code for increase/decrease of liquidity with credit lines in managed in PHA
	<FrstAgt> ▶ <BIC> NCBBBGAAXXX </BIC>	BIC of Home CB of SB (RTGS account to be debited in SSP)
	<PmtTx> ▶ <PmtId> ▶ <InstrId> ABC1234 </InstrId>	Unique reference number of transaction (assigned by initiating party)

2 Flow of payments/transactions

2.4 AS transactions

2.4.6 Settlement on dedicated liquidity account

	▶ <EndToEndId> XYZ456 </EndToEndId>	Related reference
	<Amt> ▶ <InstAmt> 1,000,000.00 </Amt>	Amount
	<FnIAgt> ▶ <BIC> CREDLU2L987 </BIC>	BIC of SB (Sub account to be credited in SSP)
	<FnIAgtAcct> ▶ <DmstAcct> ▶ <Id> LU45645AB01 </Id>	Account number of Sub account of SB
	<RmInf> ▶ <Unstrd> HKL1234 </Unstrd>	Information from ordering institution to final beneficiary
② ASInitiationStatus from ASI to Home CB of SB	<Grpld> ABCDE1234 </Grpld>	Unique ID of initial ASTransferInitiation ①
③ MT 900 (optional) from ASI to Home CB of SB	S: TRGTXEPMASI	TRGTXEPMASI
	R: NCBBBGAAXXX	BIC of Home CB of SB (debited RTGS account)
	20: GGT5698	TRN of this message
	21: XYZ456	Copy of EndToEndIdentification of initial ASTransferInitiation
	25: GR12345678910111213141516171819202	Debited RTGS account
	32A: 1,000,000.00	Amount debited
	52a: ASBICAAAXXX	Ancillary System BIC
	72: /ASDEBT/	Debtor from ① (if filled)
③ MT 910 (optional) from ASI to Settlement Bank (creditor)	S: TRGTXEPMASI	TRGTXEPMASI
	R: CREDLU2L987	BIC of SB (credited Sub account)
	20: ZBD6542	TRN of this message
	21: XYZ456	Copy of EndToEndIdentification of initial ASTransferInitiation
	25: LU45645AB01	credited Sub account
	32A: 1,000,000.00	Amount credited
	52a: ASBICAAAXXX	Ancillary System BIC
	72: /ASCRED/	Creditor from ① (if filled)
④ ReturnAccount from ASI to Ancillary System	<MsgId> ▶ <Id> EEA7895 </Id>	Unique ID for the file (assigned by ASI)
	<DmstAcct> ▶ <Id> LU45645AB01 </Id>	Sub account number
	<AcctOwnr> CREDLU2L987 </AcctOwnr>	BIC of the SB (sub-account owner)

2 Flow of payments/transactions

2.4 AS transactions

2.4.6 Settlement on **dedicated liquidity account**

	<MulBal> ▶ <Amt> 1,000,000.00 </Amt> ▶ <Tp> PYMT </Tp>	Increase or decrease amount of operation
	<MulBal> ▶ <Amt> 6,543,987.00 </Amt> ▶ <Tp> BOOK </Tp>	New balance on sub-account

2 Flow of payments/transactions

2.4 AS transactions

2.4.6 Settlement on dedicated liquidity account

2.4.6.1.1.6 Decrease of dedicated liquidity (initiated by CB on behalf of AS)

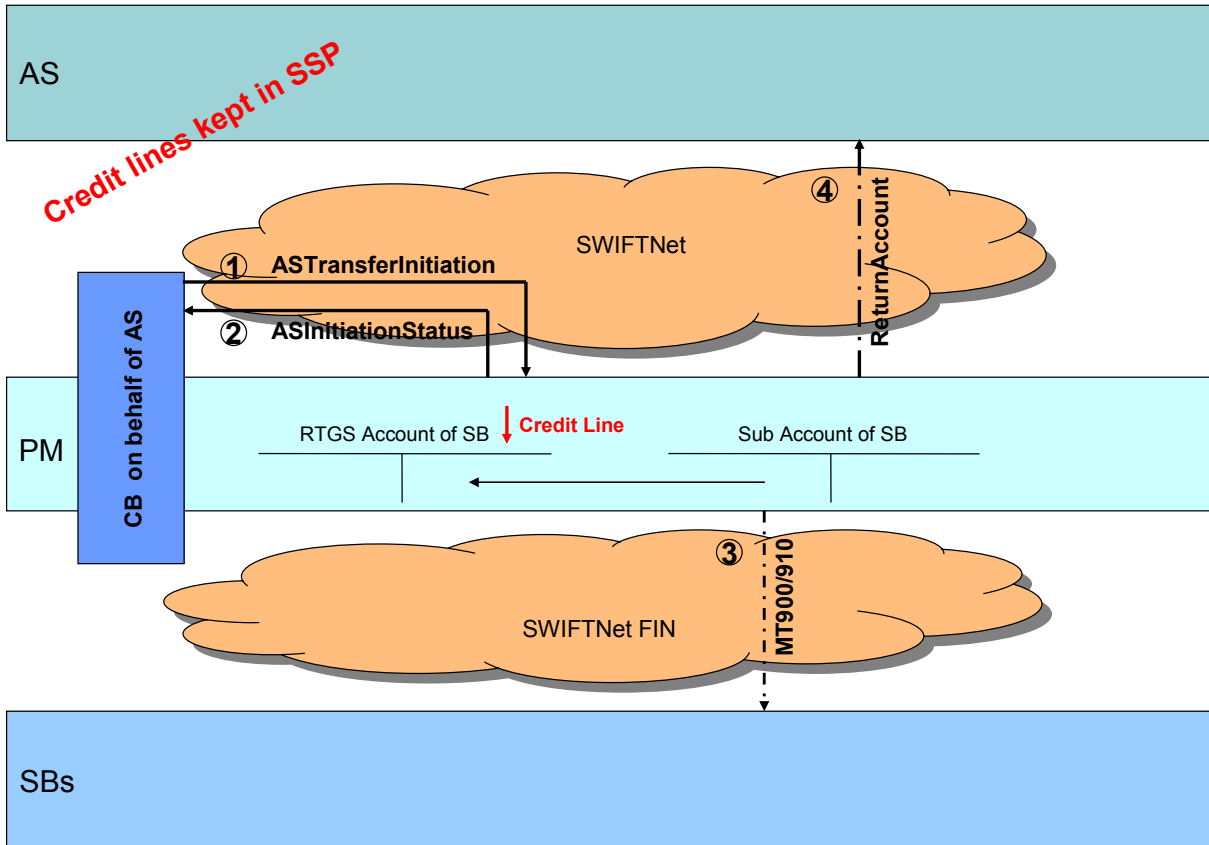

Message	Tag/field of message	Field entry
① ASTransferInitiation from CB to ASI on behalf of AS	<Grpld> ABCDE1234 </Grpld>	Unique ID for the file (assigned by sender)
	<InitgPty> ▶ <BIC> ASBICAAAXXX </BIC>	Ancillary System BIC
	<PmtInf> ▶ <PmtSchme> ▶ <Cd> CSP </Cd>	CSP: PaymentScheme Code for connected payments on SSP accounts
	<FrstAgt> ▶ <BIC> CREDLU2L987 </BIC>	BIC of SB (Sub account to be debited in SSP)
	<PmtTx> ▶ <PmtId> ▶ <InstrId> ABC1234 </InstrId>	Unique reference number of transaction (assigned by initiating party)
	▶ <EndToEndId> XYZ456 </EndToEndId>	Related reference

2 Flow of payments/transactions

2.4 AS transactions

2.4.6 Settlement on dedicated liquidity account

	<Amt> ► <InstAmt> 500,000.00 </Amt>	Amount
	<FnIAgt> ► <BIC> CREDLU2L987 </BIC>	BIC of SB (RTGS account to be credited in SSP)
	<FnIAgtAcct> ► <DmstAcct> ► <Id> LU45645AB01 </Id>	Account number of RTGS account of SB
	<Rmlnf> ► <Unstrd> HKL1234 </Unstrd>	Information from ordering institution to final beneficiary
② ASInitiationStatus from ASI to Home CB of SB	<Grpld> ABCDE1234 </Grpld>	Unique ID of initial ASTransferInitiation ①
③ MT 900 (optional) from ASI to Settlement Bank (debtor)	S: TRGTXEPMASI	TRGTXEPMASI
	R: CREDLU2L987	BIC of SB (debited Sub account)
	20: MQR6354	TRN of this message
	21: XYZ456	EndtoEndIdentification field of initial ASTransferInitiation
	25: LU45645AB01	Debited Sub account
	32A: 500,000.00	Amount debited
	52a: ASBICAAAXX	Ancillary System BIC
	72: /ASDEBT/	Debtor from ① (if filled)
③ MT 910 (optional) from ASI to Settlement Bank (creditor)	S: TRGTXEPMASI	TRGTXEPMASI
	R: CREDLU2L987	BIC of SB (credited RTGS account)
	20: WMZ2345	TRN of this message
	21: XYZ456	EndtoEndIdentification field of initial ASTransferInitiation ①
	25: GR123456789101112131415 16171819202	Credited RTGS account
	32A: 500,000.00	Amount credited
	52a: ASBICAAAXX	Ancillary System BIC
	72: /ASCRED/	Creditor from ① (if filled)
④ ReturnAccount from ASI to Ancillary System	<Msgld> ► <Id> EEA7895 </Id>	Unique ID for the file (assigned by ASI)
	<DmstAcct> ► <Id> LU45645AB01 </Id> <AcctOwnr> CREDLU2L987 </AcctOwnr>	Sub-account number BIC of the SB (sub-account owner)
	<MulBal> ► <Amt> 500,000.00 </Amt> ► <Tp> PYMT </Tp>	Increase or decrease amount of operation

2 Flow of payments/transactions

2.4 AS transactions

2.4.6 Settlement on **dedicated liquidity account**

	<pre><MulBal> ▶ <Amt>6,543,487.00</Amt> ▶ <Tp>BOOK</Tp></pre>	New balance on Sub account
--	---	----------------------------

2 Flow of payments/transactions

2.4 AS transactions

2.4.6 Settlement on dedicated liquidity account

2.4.6.1.1.7 Liquidity re-transfer (initiated by Home CB of SB)

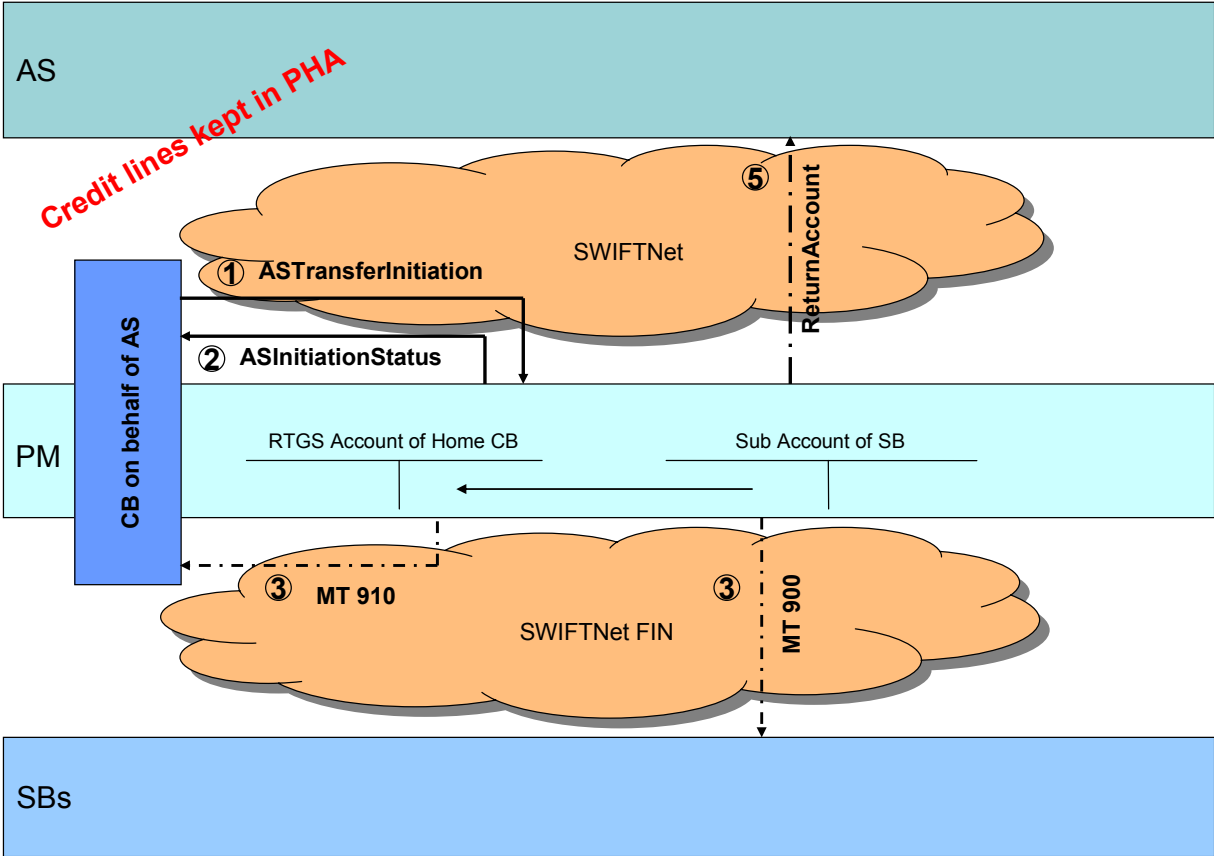

Message	Tag/field of message	Field entry
① ASTransferInitiation from CB to ASI on behalf of AS	<Grpld>ABCDE1234</Grpld>	Unique ID for the file (assigned by sender)
	<InitgPty> ▶ <BIC>ASBICAAAXXX</BIC>	Ancillary System BIC
	<PmtInf> ▶ <PmtSchme> ▶ <Cd>CHA</Cd>	CHA: PaymentScheme Code for increase/decrease of liquidity with credit lines in managed in PHA
	<FrstAgt> ▶ <BIC>CREDLU2L987</BIC>	BIC of SB (Sub account to be debited in SSP)

2 Flow of payments/transactions

2.4 AS transactions

2.4.6 Settlement on dedicated liquidity account

	<p><PmtTx> ▶ <PmtId> ▶ <InstrId>ABC1234</InstrId> ▶ <EndToEndId>XYZ456</EndToEndId></p>	<p>Unique reference number of transaction (assigned by initiating party) Related reference</p>
	<p><Amt> ▶ <InstAmt>500,000.00</Amt></p>	Amount
	<p><FnIAgt> ▶ <BIC>NCBBBGAAXXX</BIC></p>	BIC of Home CB of SB (RTGS account to be credited in SSP)
	<p><FnIAgtAcct> ▶ <DmstAcct> ▶ <Id>GR12345678910111213141516171819202</Id></p>	Account number of RTGS account of SB
	<p><Rmlnf> ▶ <Unstrd>HKL1234</Unstrd></p>	Information from ordering institution to final beneficiary
② ASInitiationStatus from ASI to Ancillary System	<p><GrpId>ABCDE1234</GrpId></p>	Unique ID of initial ASTransferInitiation ①
② MT 900 (optional) from ASI to Settlement Bank	<p>S: TRGTXEPMASI</p>	TRGTXEPMASI
	<p>R: CREDLU2L987</p>	BIC of SB (debited Sub account)
	<p>20: GGT5698</p>	TRN of this message
	<p>21: XYZ456</p>	Copy of EndToEndIdentification of initial ASTransferInitiation
	<p>25: LU45645AB01</p>	Debited Sub account
	<p>32A: 500,000.00</p>	Amount debited
	<p>52a: ASBICAAAXXX</p>	Ancillary System BIC
	<p>72: /ASDEBT/</p>	Debtor from ① (if filled)
② MT 910 (optional) from ASI to Home CB of SB (creditor)	<p>S: TRGTXEPMASI</p>	TRGTXEPMASI
	<p>R: NCBBBGAAXXX</p>	BIC of Home CB of SB (credited RTGS account)
	<p>20: ZBD6542</p>	TRN of this message
	<p>21: XYZ456</p>	Copy of EndToEndIdentification of initial ASTransferInitiation
	<p>25: GR12345678910111213141516171819202</p>	credited Sub account
	<p>32A: 500,000.00</p>	Amount credited
	<p>52a: ASBICAAAXXX</p>	Ancillary System BIC
	<p>72: /ASCRED/</p>	Creditor from ① (if filled)

2 Flow of payments/transactions

2.4 AS transactions

2.4.6 Settlement on **dedicated liquidity account**

④ ReturnAccount from ASI to Ancillary System	<MsgId> ▶ <Id> EEA7895 </Id>	Unique ID for the file (assigned by ASI)
	<DmstAcct> ▶ <Id> LU45645AB01 </Id>	Sub-account number
	<AcctOwnr> CREDLU2L987 </AcctOwnr>	BIC of the SB (sub-account owner)
	<MulBal> ▶ <Amt> 500,000.00 </Amt> ▶ <Tp> PYMT </Tp>	Increase or decrease amount of operation
	<MulBal> ▶ <Amt> 6,543,487.00 </Amt> ▶ <Tp> BOOK </Tp>	New balance on Sub account

2 Flow of payments/transactions

2.4 AS transactions

2.4.6 Settlement on dedicated liquidity account

2.4.6.1.2 Automatic liquidity increase used mandated payment (initiated by AS)

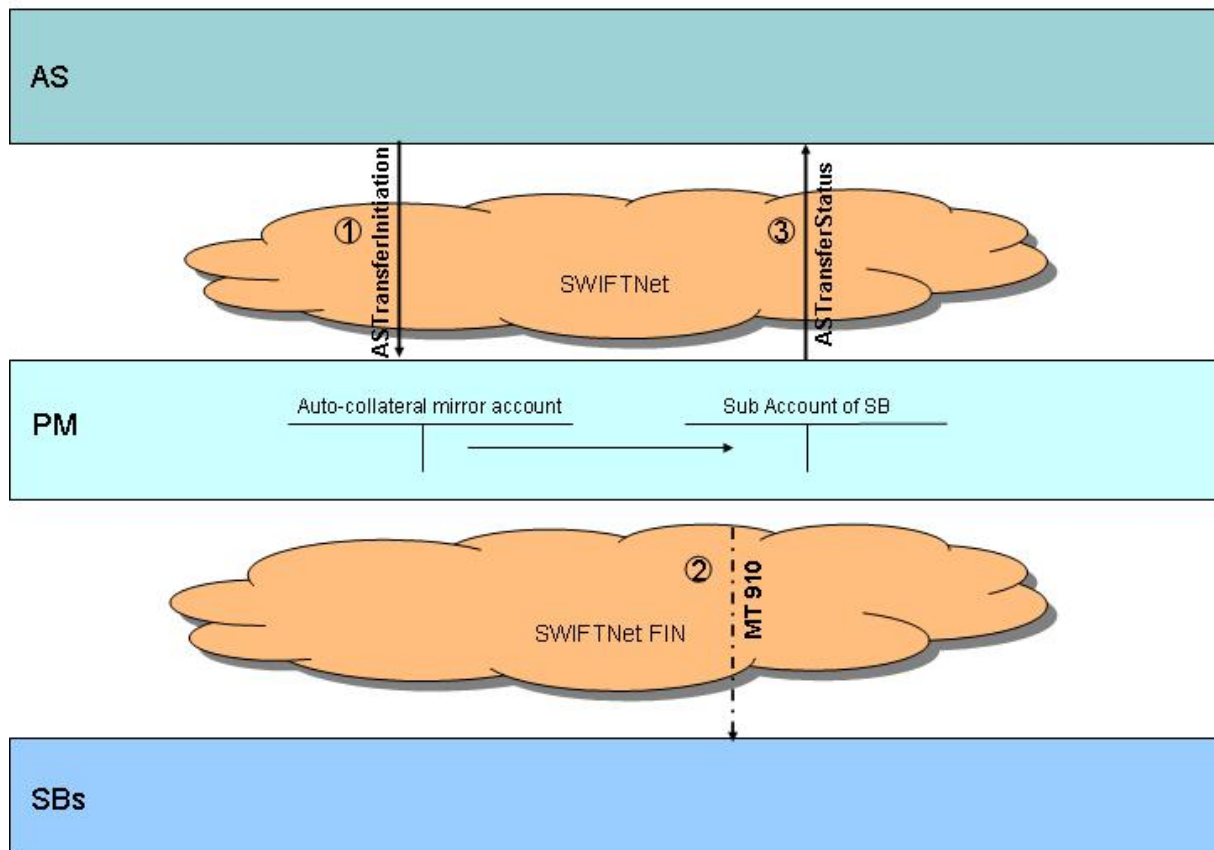

Message	Tag/field of message	Field entry
① ASTransferInitiation from Ancillary System to ASI	<GrpId>ABCDE1234</GrpId>	Unique ID for the file (assigned by sender)
	<PmtInf> ▶ <PmtSchme> ▶ <Cd>COL</Cd>	COL : PaymentScheme Code for mandated payments concerning auto-collateralisation
	<FrstAgt> ▶ <BIC>CMIRLU2LXXX</BIC>	BIC of auto-collateral mirror account

2 Flow of payments/transactions

2.4 AS transactions

2.4.6 Settlement on dedicated liquidity account

	<PmtTx> ▶ <PmtId> ▶ <InstrId> ABC1234 </InstrId> ▶ <EndToEndId> XYZ456 </EndToEndId>	Unique reference number of transaction (assigned by initiating party) Related reference
	<Amt> ▶ <InstAmt> 1,000,000.00 </Amt>	Amount
	<FnlAgt> ▶ <BIC> CREDLU2L987 </BIC>	BIC of SB (Sub account to be credited in SSP)
	<FnlAgtAcct> ▶ <DmstAcct> ▶ <Id> LU45645AB01 </Id>	Account number of Sub account of SB
	<RmInf> ▶ <Unstrd> HKL1234 </Unstrd>	Information from ordering institution to final beneficiary
② MT 910 (optional) from ASI to Settlement Bank (creditor)	S: TRGTXEPMASI	TRGTXEPMASI
	R: CREDLU2L987	BIC of SB (credited Sub account)
	20: ZBD6542	TRN of this message
	21: XYZ456	Copy of EndToEndIdentification of initial ASTransferInitiation
	25: LU123456ABC01	Credited Sub account
	32A: 1,000,000.00	Amount credited
	52a: CASIDFFXXX	BIC of AS
	72: /ASCRED/	Creditor from ① (if filled)
③ ASInitiationStatus from ASI to Ancillary System	<GrpId> ABCDE1234 </GrpId>	Unique ID of initial ASTransferInitiation

2 Flow of payments/transactions

2.4 AS transactions

2.4.6 Settlement on dedicated liquidity account

2.4.6.1.3 Automatic liquidity increase used mandated payment initiated by CB or CCBM2 on behalf of AS

Message	Tag/field of message	Field entry
① ASTransferInitiation from CB or CCBM2 to ASI on behalf of Ancillary System	<GrpId> ABCDE1234 </GrpId>	Unique ID for the file (assigned by sender)
	<InitgPty> ▶ <BIC> ASBICAAAXXX </BIC>	BIC of AS. Only filled in case a CB or CCBM2 is sending the message on behalf of an AS. If the sender is a CB then the Initiating Party must be filled with a BIC of an authorised AS and member of this CB. If the sender is CCBM2 then the initiating party must be filled with a BIC of an authorised AS with a CCBM2Flag 'Y' and the sender DN is defined for CCBM2 for the CB of the AS.
	<PmtInf> ▶ <PmtSchme> ▶ <Cd> COL </Cd>	COL : PaymentScheme Code for mandated payments concerning auto-collateralisation
	<FrstAgt> ▶ <BIC> CMIRLU2LXXX </BIC>	BIC of auto-collateral mirror account
	<PmtTx> ▶ <PmtId> ▶ <InstrId> ABC1234 </InstrId> ▶ <EndToEndId> XYZ456 </EndToEndId>	Unique reference number of transaction (assigned by initiating party) Related reference
	<Amt> ▶ <InstAmt> 1,000,000.00 </Amt>	Amount
	<FnlAgt> ▶ <BIC> CREDLU2L987 </BIC>	BIC of SB (Sub account to be credited in SSP)
	<FnlAgtAcct> ▶ <DmstAcct> ▶ <Id> LU45645AB01 </Id>	Account number of Sub account of SB
	<Rmlnf> ▶ <Unstrd> HKL1234 </Unstrd>	Information from ordering institution to final beneficiary

2 Flow of payments/transactions

2.4 AS transactions

2.4.6 Settlement on dedicated liquidity account

② MT 910 (optional) from ASI to Settlement Bank (creditor)	S: TRGTXEPMASI	TRGTXEPMASI
	R: CREDLU2L987	BIC of SB (credited Sub account)
	20: ZBD6542	TRN of this message
	21: XYZ456	Copy of EndToEndIdentification of initial ASTransferInitiation
	25: LU45645AB01	Credited Sub account
	32A: 1,000,000.00	Amount credited
	52a: ASBICAAAXXX	BIC of AS
	72: /ASCRED/	Creditor from ① (if filled)
③ ASInitiationStatus from ASI to Ancillary System	<GrpId>ABCDE1234</GrpId>	Unique ID of initial ASTransferInitiation
④ ReturnAccount from ASI to Ancillary System	<MsgId> ▶ <Id>EEA7895</Id>	Unique ID for the file (assigned by ASI)
	<DmstAcct> ▶ <Id>LU45645AB01</Id>	Sub account number
	<AcctOwnr>CREDLU2L987</AcctOwnr>	BIC of the SB (sub-account owner)
	<MulBal> ▶ <Amt>1,000,000.00</Amt> ▶ <Tp>PYMT</Tp>	Increase or decrease amount of operation
	<MulBal> ▶ <Amt>6,543,987.00</Amt> ▶ <Tp>BOOK</Tp>	New balance on sub-account

2 Flow of payments/transactions

2.4 AS transactions

2.4.6 Settlement on dedicated liquidity account

2.4.6.1.4 Current order (initiated by SB) - liquidity credit transfer sent from SB via ICM

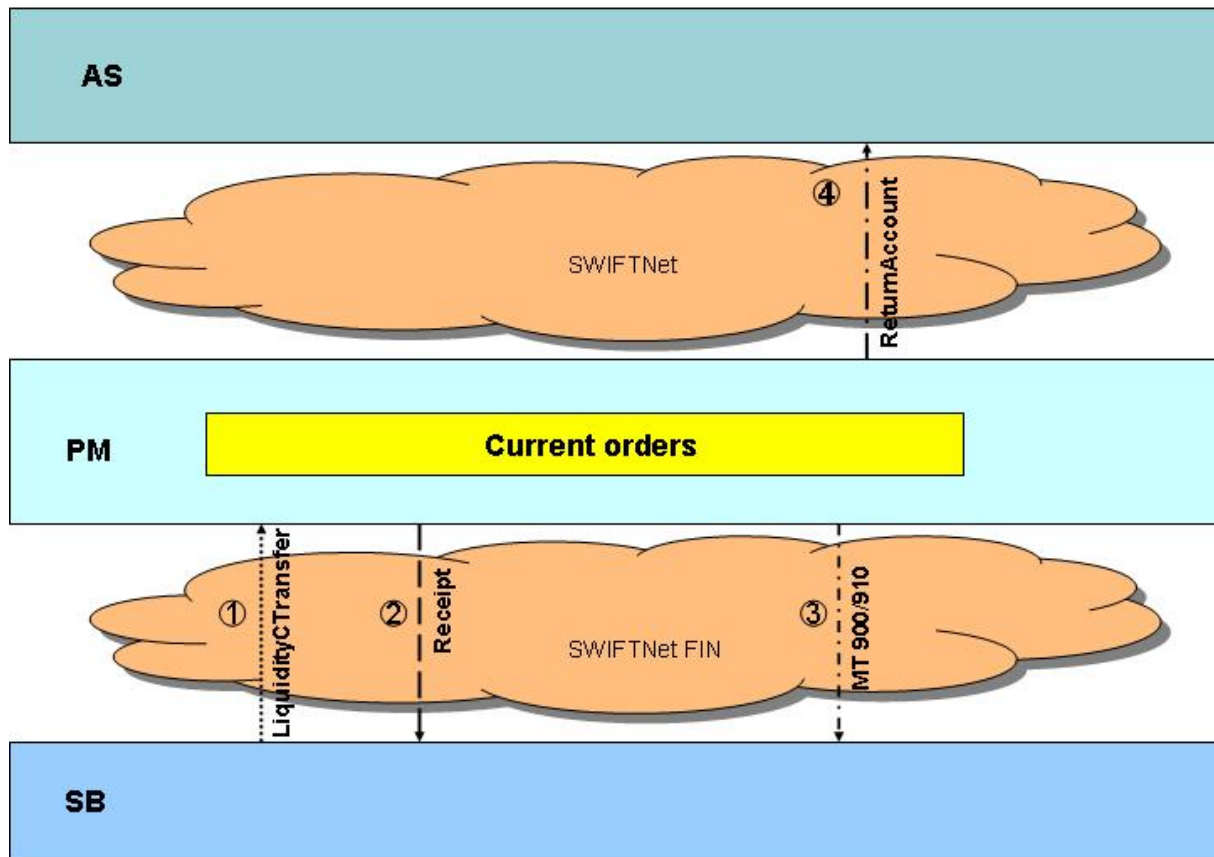

Messages	Tag/field of message	Field entry
① LiquidityCreditTransfer from ICM Note: in case of decrease on sub account: <DbtAcct> will be filled with sub account	<MsgId> ▶<Id> HGFE4321 </Id>	Unique ID for the file (assigned by sender)
	<CdtAcct> ▶<Id> ▶<DmstAcct> ▶<Id> FR9999ABC01 </Id>	Sub account to be credited
	<TrfdAmt> ▶<AmtWthtCcy> 1,000,000.00 </AmtWthtCcy>	Amount

2 Flow of payments/transactions

2.4 AS transactions

2.4.6 Settlement on dedicated liquidity account

② Receipt from ICM to Settlement Bank	<MsgId> ▶ <Id> EFGH1234 </Id>	Unique ID for the file (assigned by ASI)
	<RltdRef> ▶ <Ref> ABC12345 </Id>	Copy of MessageIdentification of initial LiquidityCreditTransfer
③ MT 900 (optional) from ASI to Settlement Bank (debtor)	S: TRGTXEPMASI	TRGTXEPMASI
	R: BANKFRPPXXX	BIC of debited account
	20: IMO987	TRN of this message
	21: HGFE4321	Copy of MessageIdentification of initial LiquidityCreditTransfer
	25: FR12345678910111213141516171819202	Debited RTGS account
	32A: 1,000,000.00	Amount debited/credited
	52a: BANKFRPPXXX	BIC of Settlement Bank (sub-account owner)
	72: /ASDEBT/	Debited account from ① (if filled)
③ MT 910 (optional) from ASI to Settlement Bank (creditor)	S: TRGTXEPMASI	TRGTXEPMASI
	R: BANKFRPPXXX	BIC of credited account
	20: ...	TRN of this message
	21: HGFE4321	Copy of MessageIdentification of initial LiquidityCreditTransfer
	25: FR9999ABC01	Credited sub account
	32A: 1,000,000.00	Amount debited/credited
	52a: BANKFRPPXXX	BIC of Settlement Bank (sub-account owner)
	72: /ASCRED/	Credited account from ① (if filled)
④ ReturnAccount from ASI to Ancillary System	<MsgId> ▶ <Id> CBA1234 </Id>	Unique ID for the file (assigned by ASI)
	<DmstAcct> ▶ <Id> FR9999ABC01 </Id>	Sub-account number
	<AcctOwnr> BANKFRPPXXX </AcctOwnr>	BIC of Settlement Bank
	<MulBal> ▶ <Amt> 1,000,000.00 </Amt> ▶ <Tp> PYMT </Tp>	Increase or decrease amount of operation
	<MulBal> ▶ <Amt> 7,543,487.00 </Amt> ▶ <Tp> BOOK </Tp>	New balance on sub-account

2 Flow of payments/transactions

2.4 AS transactions

2.4.6 Settlement on dedicated liquidity account

2.4.6.1.5 Current order (initiated by AS)

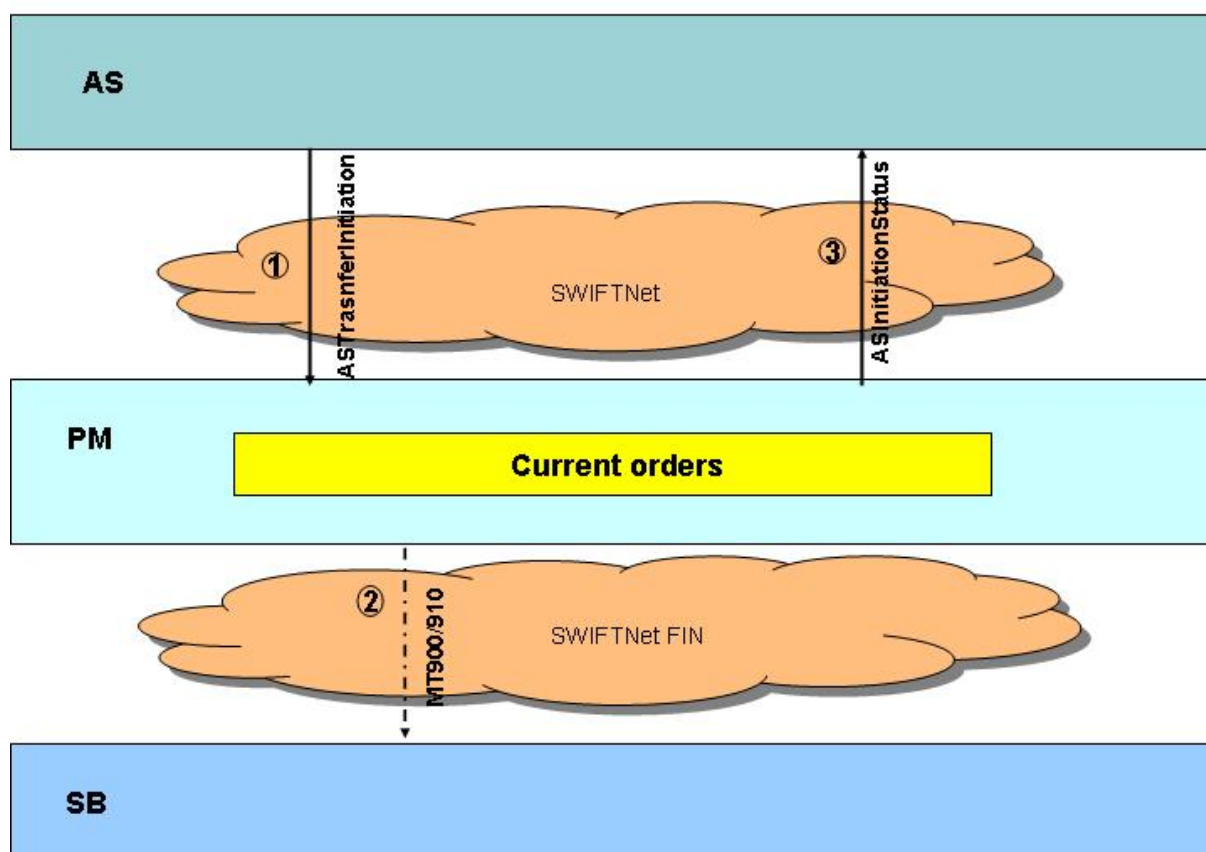

Message	Tag/field of message	Field entry
① ASTransferInitiation from Ancillary System to ASI	<Grpld>ABCDE1234</Grpld>	Unique ID for the file (assigned by sender)
	<InitgPty> ▶<BIC>INNDNL2UXXX</BIC>	BIC of AS if CB sends this message on its behalf – Initiating Party
	<PmtSchme> <Cd>CUO</Cd>	Payment Scheme Code for current orders
	<FrstAgt> ▶<BIC>CREDLU2L987</BIC>	RTGS account to be debited in SSP

2 Flow of payments/transactions

2.4 AS transactions

2.4.6 Settlement on dedicated liquidity account

	<PmtTx> ▶<PmtId> ▶<InstrId> ABC1234 </InstrId> ▶<EndToEndId> XYZ456 </EndToEndId>	Unique reference number of transaction (assigned by initiating party) Related reference
	<Amt> ▶<InstAmt> 500.00 </Amt>	Amount
	<FnlAgt> ▶<BIC> CREDLU2L987 </BIC>	RTGS account to be credited in SSP
	<FnlAgtAcct> ▶<DmstAcct> ▶<Id> LU45645AB01 </Id>	Sub-account number in case of increasing transaction
	<Rmlnf> ▶<Unstrd> HKL1234 </Unstrd>	Information from ordering institution to final beneficiary
② MT 900 (optional) from ASI to Settlement Bank (debtor)	S: TRGTXEPMASI	TRGTXEPMASI
	R: CREDLU2L987	BIC of debited account
	20: WVV9876	TRN of this message
	21: XYZ456	Copy of EndToEndIdentification of initial ASTransferInitiation
	25: GR12345678910111213141516171819202	Debited RTGS account
	32A: 500.00	Amount debited/credited
	52a: INNDNL2UXXX	BIC of AS
	72: /ASDEBT/	Debtor from ① (if filled)
② MT 910 (optional) from ASI to Settlement Bank (creditor)	S: TRGTXEPMASI	TRGTXEPMASI
	R: CREDLU2L987	BIC of credited account
	20: LKJ6541	TRN of this message
	21: XYZ456	Copy of EndToEndIdentification of initial ASTransferInitiation
	25: LU45645AB01	Credited sub-account
	32A: 500.00	Amount debited/credited
	52a: INNDNL2UXXX	BIC of AS
	72: /ASCRED/	Creditor from ① (if filled)
③ ASInitiationStatus from ASI to Ancillary System	<Grpld> ABCDE1234 </Grpld>	Unique ID of initial ASTransferInitiation

2 Flow of payments/transactions

2.4 AS transactions

2.4.6 Settlement on dedicated liquidity account

2.4.6.2 Integrated model

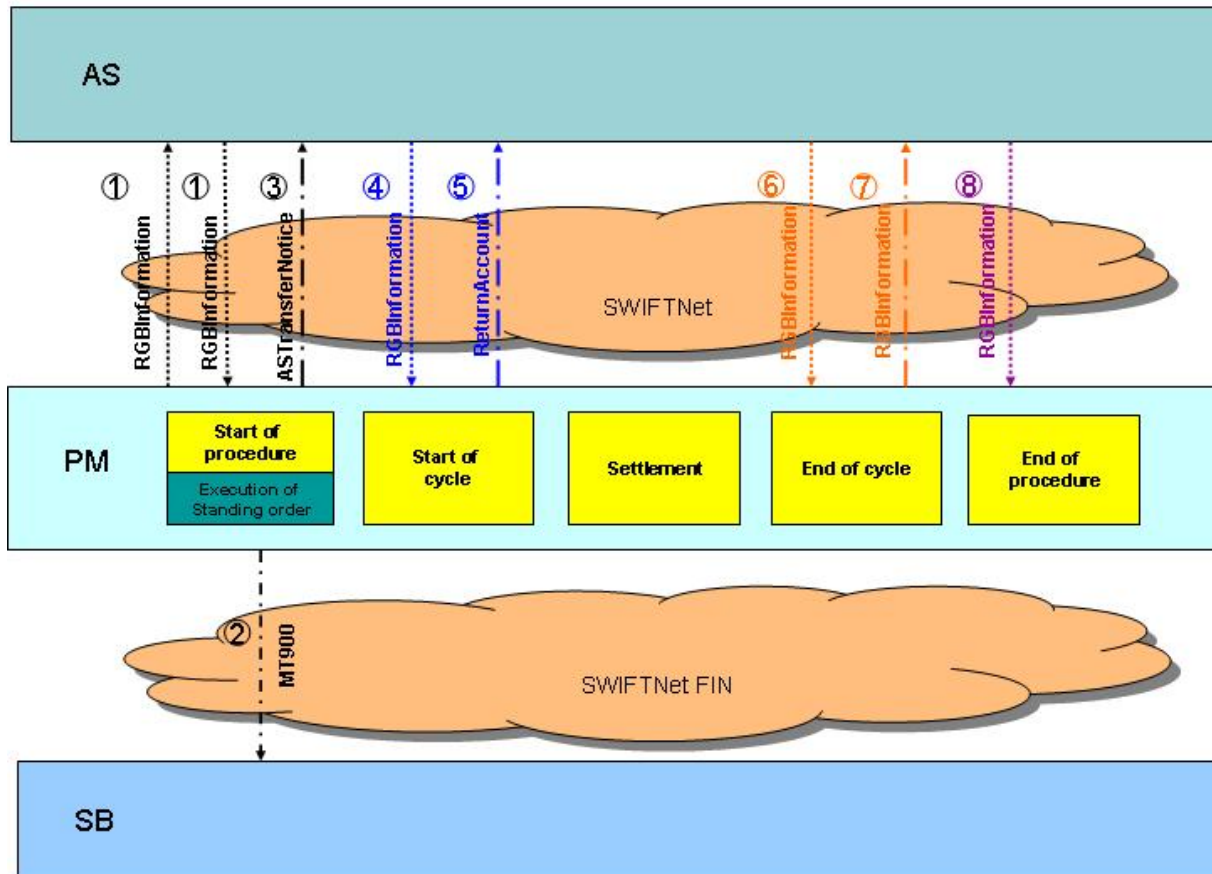

Message	Tag/field of message	Field entry
① ReturnGeneralBusiness Information	<MsgId> ▶ <Id> ABC1234 </Id>	Unique ID for the file (assigned by ASI)
	<BizInfRef> CDE123 </BizInfRef>	Unique ID of general business information system (assigned by ASI)
	<Sbjt> OVN/DAY-PROC-OPEN </Sbjt>	Subject of message
② MT 900 (optional) from ASI to Settlement Bank (debtor)	S: TRGTXEPMASI	TRGTXEPMASI
	R: BBBBGRAAXX	BIC of debited RTGS account
	20: JLL6824	TRN of this message
	21: ...	Internal SSP reference

2 Flow of payments/transactions

2.4 AS transactions

2.4.6 Settlement on dedicated liquidity account

	25: GR1234567891011121314151 6171819202	Debited RTGS account
	32A: 500.00	Amount debited
	52a: BBBBGRAAXX	BIC of Settlement Bank
	72: /ASDEBT/	Field 52 of the standing order
③ ATransferNotice from ASI to Ancillary System	<Grpld>UVW1234</Grpld>	Unique ID for the file (assigned by ASI)
	<Dbtr> ▶ <BIC>BANKFRPPXXX</BIC>	Third party/ordering institution to be debited (Debtor)
	<FrstAgt> ▶ <BIC>BBBBGRAAXX</BIC>	RTGS account to be debited in SSP
	<PmtTx> ▶ <PmtId> ▶ <InstrId>DEF1234</InstrId> ▶ <EndToEndId>DEF1234</EndToEndId>	▶ Unique reference number of transaction (assigned by initiating party) ▶ Related reference (the same like <InstrId>)
	<Amt> ▶ <InstAmt>500.00</Amt>	Amount of standing order or reduced in a pro-rata mode
	<Cdtr> ▶ <BIC>CREDFRPPXXX</BIC>	Third party's/final beneficiary's account to be credited
	<FnIAgt> ▶ <BIC>CREDLL2L987</BIC>	mirror account credited finally in SSP
	<RmInf> ▶ <Unstrd>HKL1234</Unstrd>	Information from ordering institution to final beneficiary
④ ReturnGeneralBusiness Information from Ancillary System to ASI	<MsgId> ▶ <Id>DEF9876</Id>	Unique ID for the file (assigned by AS)
	<BizInfRef>DEF123</BizInfRef>	Unique ID of general business information system (assigned by AS)
	<Sbjt>OVN/DAY-CYCL-OPEN</Sbjt>	Subject of the message
⑤ ReturnAccount from ASI to Ancillary System	<MsgId> ▶ <Id>GHI1234</Id>	Unique ID for the file (assigned by ASI)
	<DmstAcct> ▶ <Id>CREDLL2L987</Id>	BIC of mirror account
	<MulBal> ▶ <Amt>1234.56</Amt> ▶ <Tp>BOOK</Tp>	Balance on mirror account
⑥ ReturnGeneralBusiness Information from Ancillary System to ASI	<MsgId> ▶ <Id>JKL1234</Id>	Unique ID for the file (assigned by AS)
	<BizInfRef>CDE123</BizInfRef>	Unique ID of general business information system (assigned by AS)

2 Flow of payments/transactions

2.4 AS transactions

2.4.6 Settlement on dedicated liquidity account

	<Sbjt>OVN/DAY-CYCL-CLOS</Sbjt>	Subject of message
	<SbjtDtIs>ABBDLULUXXX</SbjtDtIs>	BIC of AS, if the sender is a CB on behalf of the AS
⑦ ReturnGeneralBusiness Information from ASI to Ancillary System	<MsgId> ▶ <Id>XYZ1234</Id>	Unique ID for the file (assigned by the ASI)
	<BizInfRef>CDE123</BizInfRef>	Copy of BusinessInformation Reference of initial ReturnGeneral BusinessInformation
	<Sbjt>LIQ-CYCL-END</Sbjt>	Subject of message
⑧ ReturnGeneralBusiness Information from Ancillary System to ASI	<MsgId> ▶ <Id>ZWZ1234</Id>	Unique ID for the file (assigned by AS)
	<BizInfRef>EFG123</BizInfRef>	Unique ID of general business information system (assigned by AS)
	<Sbjt>OVN-PROC-CLOS</Sbjt>	Subject of message

2 Flow of payments/transactions

2.4 AS transactions

2.4.6 Settlement on dedicated liquidity account

2.4.6.2.1 Current order (initiated by AS) (increase on mirror account)

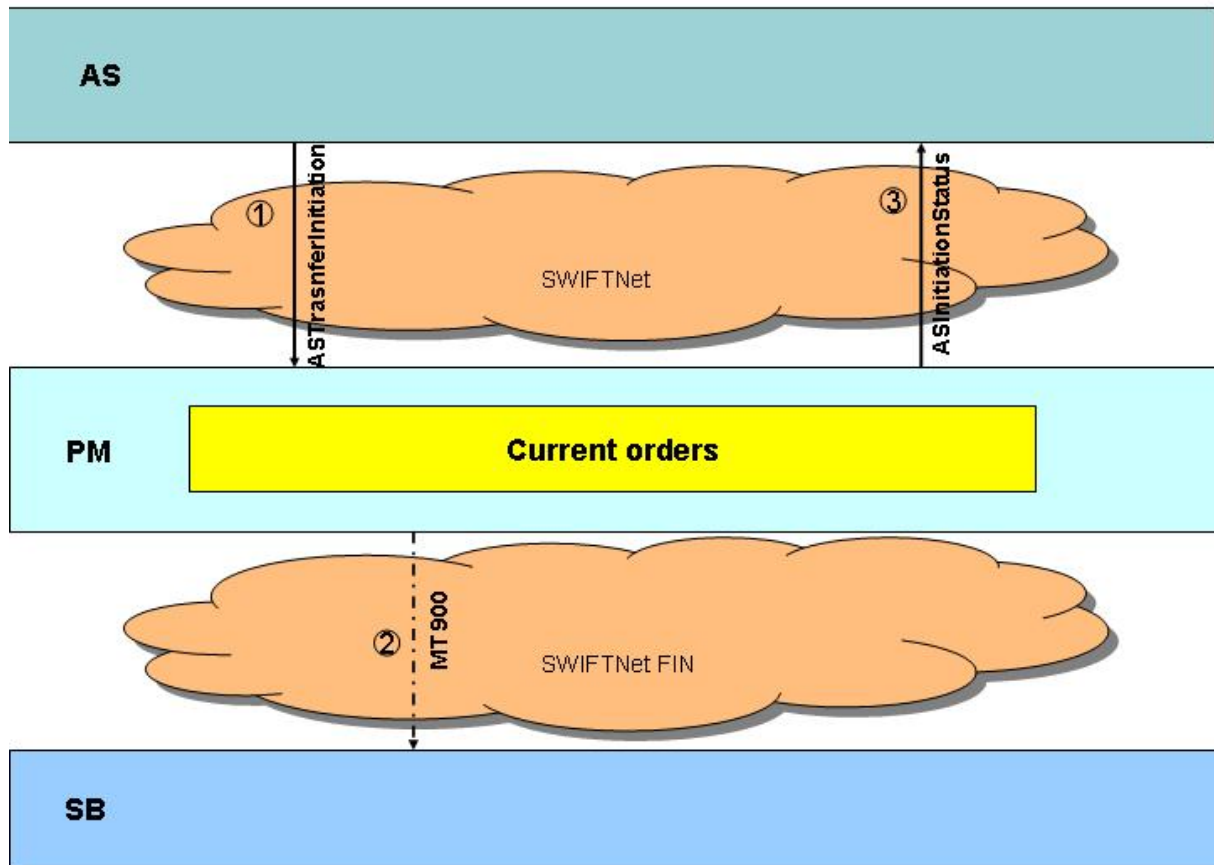

Message	Tag/field of message	Field entry
① ATransferInitiation from Ancillary System to ASI	<Grpld> ABCDE1234 </Grpld>	Unique ID for the file (assigned by sender)
	<InitgPty> ▶<BIC> INNDNL2UXXX </BIC>	BIC of AS if CB sends this message on its behalf – Initiating Party
	<PmtSchme> <Cd> CUO </Cd>	Payment Scheme Code for current orders
	<FrstAgt> ▶<BIC> BBBGBRAAXX </BIC>	RTGS account to be debited in SSP

2 Flow of payments/transactions

2.4 AS transactions

2.4.6 Settlement on dedicated liquidity account

	<PmtTx> ▶ <PmtId> ▶ <InstrId> ABC1234 </InstrId> ▶ <EndToEndId> XYZ456 </EndToEndId> <Amt> ▶ <InstAmt> 500.00 </Amt> <FnlAgt> ▶ <BIC> CREDLU2L987 </BIC> <Rmlnf> ▶ <Unstrd> HKL1234 </Unstrd>	Unique reference number of transaction (assigned by initiating party) Related reference Amount BIC of mirror account Information from ordering institution to final beneficiary
② MT 900 (optional) from ASI to Settlement Bank (debtor)	S: TRGTXEPMASI	TRGTXEPMASI
	R: BBBBGRAAXXX	BIC of debited RTGS account
	20: XXW5627	TRN of this message
	21: XYZ345	Copy of EndToEndIdentification of initial ASTransferInitiation
	25: GR12345678910111213141516 171819202	Debited RTGS account
	32A: 500.00	Amount to be debited
	52a: INNDNL2UXXX	BIC of AS
72: /ASDEBT/	Debtor from ① (if filled)	
③ ASInitiationStatus from ASI to Ancillary System	<Grpld> ABCDE1234 </Grpld>	Unique ID of initial ASTransferInitiation

2 Flow of payments/transactions

2.4 AS transactions

2.4.6 Settlement on dedicated liquidity account

2.4.6.2.2 Current order (initiated by SB via SBTransferInitiation)

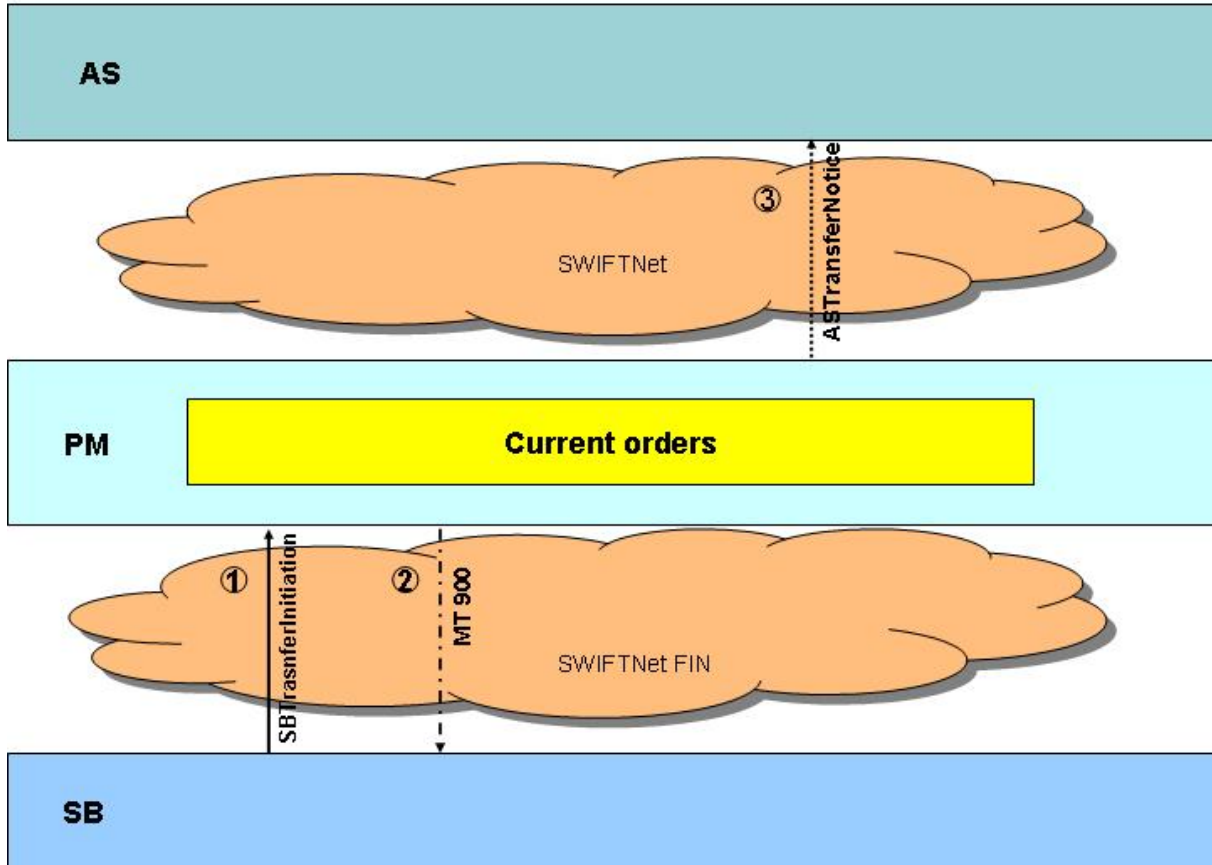

Message	Tag/field of message	Field entry
① SBTransferInitiation (via ICM) from Settlement Bank to ASI	<Grpld> ABCDE1234 </Grpld>	Unique ID for the file (assigned by sender)
	<DbtrAcct> ▶ <BIC> BANKFRPPXXX </Id>	Third party's/ordering institution's BIC to be debited
	<FrstAgt> ▶ <BIC> BBBGBRAAXX </BIC>	RTGS account to be debited (Settlement Bank)
	<PmtTx> ▶ <PmtId> ▶ <InstrId> ABC1234 </InstrId> ▶ <EndToEndId> XYZ456 </EndToEndId>	Unique reference number of transaction (assigned by initiating party) Related reference

2 Flow of payments/transactions

2.4 AS transactions

2.4.6 Settlement on dedicated liquidity account

	<Amt> ▶<InstAmt> 500.00 </Amt>	Amount to be debited
	<CrtrAcct> ▶<Id> FR98765CC01 </Id>	Third party's/final beneficiary's account to be credited
	<FnlAgt> ▶<BIC> BDFEFRPPMIR </BIC>	BIC of mirror account
	<Rmlnf> ▶<Unstrd> HKL1234 </Unstrd>	Information from ordering institution to final beneficiary
② MT 900 (optional) from ASI to Settlement Bank (debtor)	S: TRGTXEPMASI	TRGTXEPMASI
	R: BBBBGRAAXXX	BIC of debited RTGS account
	20: JUR86542	TRN of this message
	21: XYZ456	Copy of EndToEndIdentification of initial SBTransferInitiation
	25: GR12345678910111213141516 171819202	Debited RTGS account
	32A: 500.00	Amount to be debited
	52a: BBBBGRAAXXX	BIC of Settlement Bank (First Agent of initial SBTransferInitiation)
72: /ASDEBT/++ABC1234	Debtor from initial SBTransferInitiation	
③ ASTransferNotice from ASI to Ancillary System	<Grpld> ABCDE1234 </Grpld>	Unique ID for the file (assigned by ASI)
	<Dbtr> ▶<BIC> BANKFRPPXXX </BIC>	▶ BIC of third party/ordering institution to be debited
	<FrstAgt> ▶<BIC> BBBBGRAAXXX </BIC>	RTGS account to be debited in SSP
	<PmtTx> ▶<PmtId> ▶<InstrId> ZVF9799 </InstrId>	Unique reference number of transaction (assigned by initiating party)
	▶<EndToEndId> XYZ345 </EndToEndId>	Related reference
	<Amt> ▶<InstAmt> 500.00 </Amt>	Amount
	<CrtrAcct> ▶<Id> FR98765CC01 </Id>	Third party's/final beneficiary's account to be credited
	<FnlAgt> ▶<BIC> BDFEFRPPMIR </BIC>	BIC of mirror account
	<Rmlnf> ▶<Unstrd> HKL1234 </Unstrd>	Information from ordering institution to final beneficiary

2 Flow of payments/transactions

2.4 AS transactions

2.4.6 Settlement on dedicated liquidity account

2.4.6.2.3 Current order (initiated by SB via MT202)

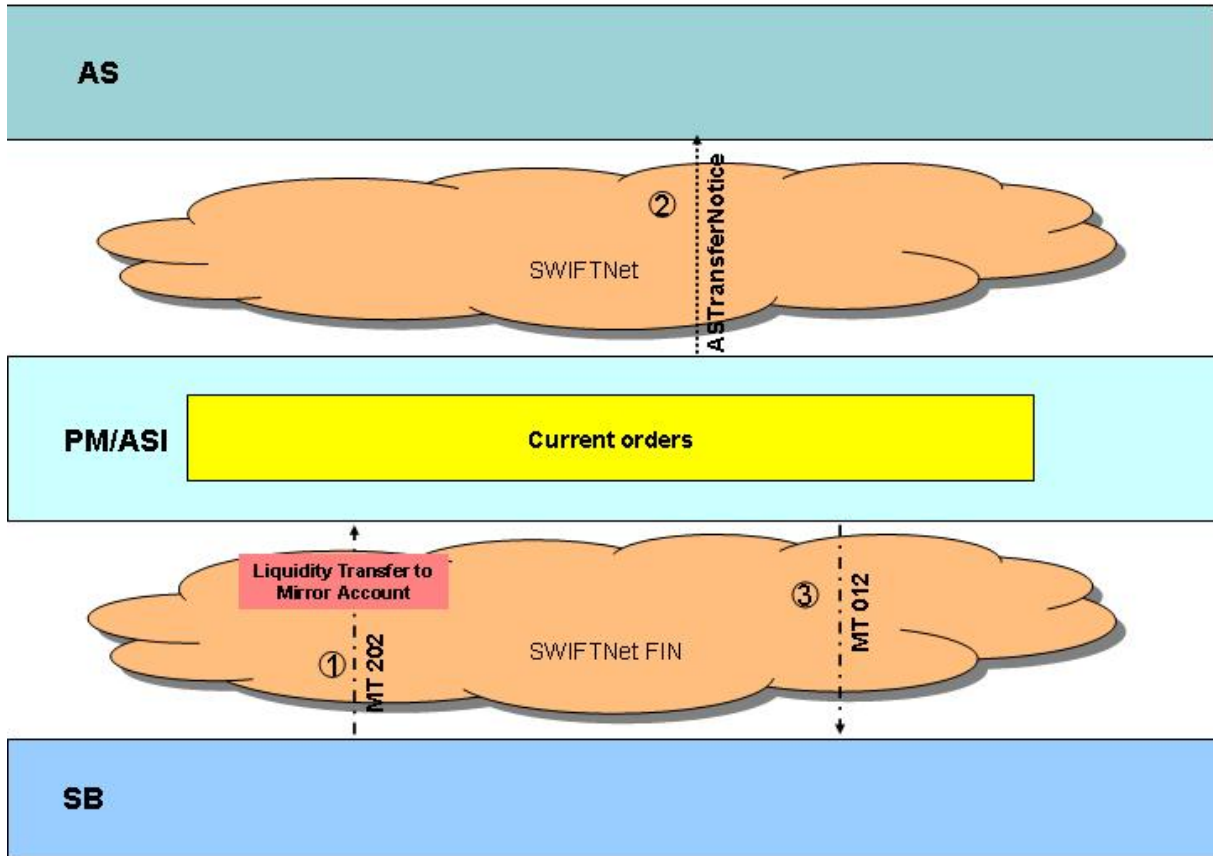

Message	Tag/field of message	Field entry
① MT 202 from Settlement Bank to ASI	S: BBBBGRAXXX	BIC of RTGS account debited in SSP (FirstAgent)
	R: TRGTXEPMASI	TRGTXEPMASI
	103: TGT	TGT (service identifier)
	20: LMG8929	TRN of this message (assigned by Settlement Bank)
	21: XYZ345	Related reference (EndToEndIdentification)
	32A: 12345678.90	Amount to be debited/credited

2 Flow of payments/transactions

2.4 AS transactions

2.4.6 Settlement on dedicated liquidity account

	<p>52d: Name of ordering institution</p> <p>52a: BANKFRPPXXX</p>	<p>▶ Third party's/ordering institution's name to be debited (debtor), if filled</p> <p>▶ Third party's/ordering institution's BIC or account to be debited (debtor), if filled</p>
	57a: CREDFRPPXXX	BIC of mirror account of the AS
	<p>58d: Name of final beneficiary</p> <p>58a: BANKFRPPXXX</p>	<p>▶ Third party's/final beneficiary's name to be credited (creditor), if filled</p> <p>▶ Third party's/final beneficiary's BIC or account to be credited (creditor), if filled</p>
	72: /ASINF/HKL1234	▶ Information from ordering institution to final beneficiary, if filled (RemittanceInformation)
② ASTransferNotice from ASI to Ancillary System	<Grpld> ABCDE1234 </Grpld>	Unique ID for the file (assigned by ASI)
	<p><Dbtr></p> <p>▶ <Nm>Name of ordering inst.</Nm></p> <p>▶ <BIC>BANKFRPPXXX</BIC></p>	<p>▶ Third party/ordering institution to be debited (debtor) - field 52 of initial MT 202 in case of option D</p> <p>▶ BIC of third party/ordering institution to be debited (debtor) - field 52 of initial MT 202 in case of option A</p>
	<p><DbtrAcct></p> <p>▶ <Id>ABC1234</Id></p>	Third party's/ordering institution's account to be debited (debtor) - field 52 of MT 202
	<p><FrstAgt></p> <p>▶ <BIC>BBBGBRAAXX</BIC></p>	RTGS account to be debited in SSP, sender of initial MT 202
	<p><PmtTx></p> <p>▶ <PmtId></p> <p>▶ <InstrId>ABC1234</InstrId></p>	Transaction Reference Number - field 20 of initial MT 202
	▶ <EndToEndId> XYZ345 </EndToEndId>	Related reference - field 21 of initial MT 202
	▶ <InstAmt> 12345678.90 </InstAmt>	Amount
	<p><Cdtr></p> <p>▶ <Nm>Name of final beneficiary</Nm></p> <p>▶ <BIC>BANKFRPPXXX</BIC></p>	<p>▶ Third party/final beneficiary to be credited (creditor) - field 58 of initial MT 202 in case of option D</p> <p>▶ BIC of third party/final beneficiary to be credited (creditor) - field 58 of initial MT 202 in case of option A</p>
	<p><CdtrAcct></p> <p>▶ <Id>FR98765CC01</Id></p>	Third party's/final beneficiary's account to be credited (creditor) - field 58 of MT 202
	<p><FnlAgt></p> <p>▶ <BIC>CREDFRPPXXX</BIC></p>	BIC of mirror account of AS

2 Flow of payments/transactions

2.4 AS transactions

2.4.6 Settlement on **dedicated liquidity account**

	<RmInf> ▶ <Unstrd> HKL1234 </Unstrd>	Information from ordering institution to final beneficiary (RemittanceInformation), if indicated in field 72 /ASINF/ of initial MT 202
③ MT 012 (<i>optional</i>) from PM to Settlement Bank	114 line 4/ LMG8929	TRN of initial MT 202 ①

2 Flow of payments/transactions

2.4 AS transactions

2.4.7 Cross-DvP: Settlement on dedicated liquidity account

2.4.7 Cross-DvP: Settlement on dedicated liquidity account

2.4.7.1 From Integrated AS to Interfaced AS

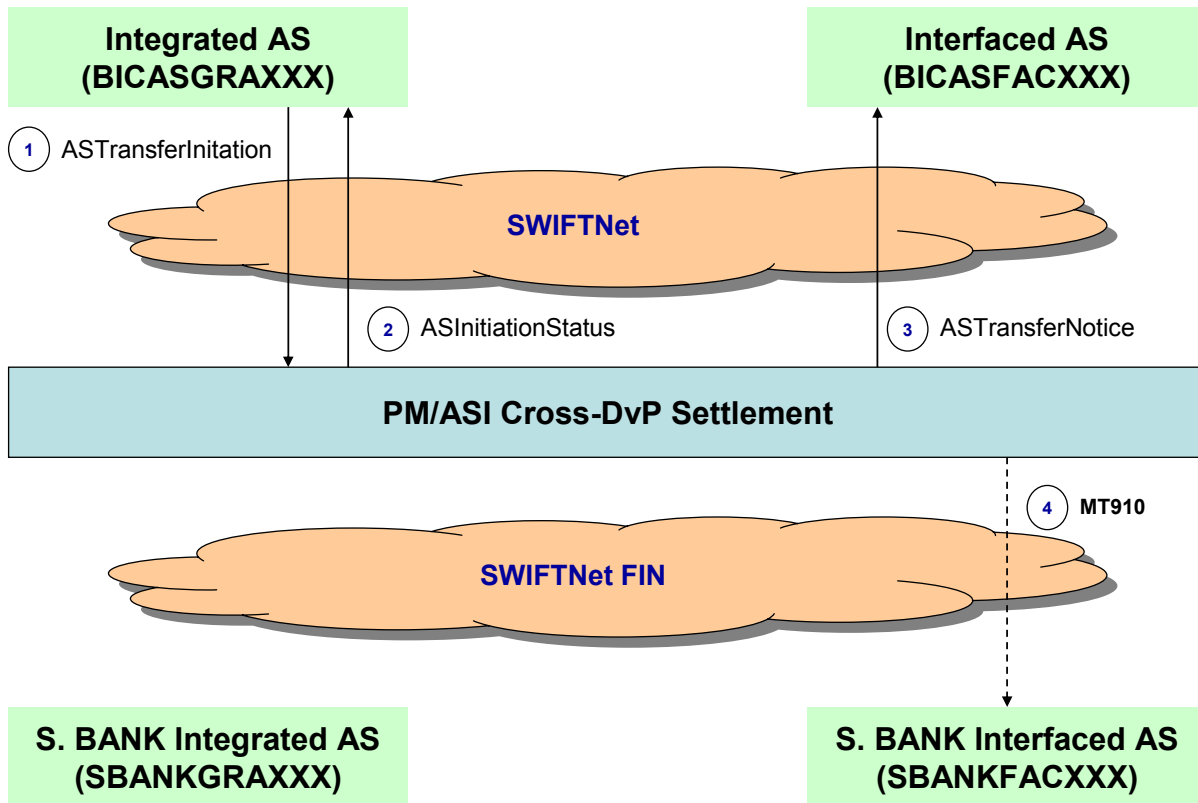

Message	Tag/field of message	Field entry
① ASTransferInitiation from Integrated AS (or its CB on its behalf) to ASI	<Grpld> ABCDE1234 </Grpld>	Unique ID for the file (assigned by sender)
	<InitgPty> ▶<BIC> BICASGRAXX </BIC>	BIC of AS if CB sends this message on its behalf – Initiating Party
	<CtpAS> ▶<BIC> BICASFACXXX </BIC>	BIC of Counterpart AS
	<PmtSchme> <Cd> CDS </Cd>	Payment Scheme Code for cross-DVP settlement
	<Dbtr> ▶<Id> SBANKGRAXX </Id>	Debtor. BIC of Settlement Bank of Integrated AS
	<FrstAgt> ▶<BIC> MIRROGRAXX </BIC>	BIC of mirror account of Integrated AS

2 Flow of payments/transactions

2.4 AS transactions

2.4.7 Cross-DvP: Settlement on dedicated liquidity account

	<PmtTx> ▶ <PmtId> ▶ <InstrId> ABC1234 </InstrId> ▶ <EndToEndId> XYZ456 </EndToEndId>	Unique reference number of transaction (assigned by initiating party) Related reference
	<Amt> ▶ <InstAmt> 500.00 </Amt>	Amount
	<FnlAgt> ▶ <BIC> SBANKFACXXX </BIC>	BIC of Settlement Bank of Interfaced AS
	<DmstAcct> ▶ <Id> SUBACC1234 </Id>	Sub-account number to be credited
	<Rmlnf> ▶ <Unstrd> HKL1234 </Unstrd>	Information from ordering institution to final beneficiary
② ASInitiationStatus from ASI to Ancillary System	<Grpld> ABCDE1234 </Grpld>	Unique ID of initial ASTransferInitiation
③ ASTransferNotice to Interfaced AS B	<CtpAS> ▶ <BIC> BICASFACXXXA </BIC>	BIC of Counterpart AS (sender of the ASTransferInitiation)
	<PmtSchme> <Cd> CDS </Cd>	Payment Scheme Code for cross-DVP settlement
	<Dbtor > ▶ <BIC> SBANKGRAXXX </BIC>	BIC of Settlement Bank of Interfaced AS
	<FrstAgt> ▶ <BIC> MIRROGRAXXX </BIC>	BIC of mirror account of Integrated AS
	<PmtTx> ▶ <PmtId> ▶ <InstrId> ABC1234 </InstrId> ▶ <EndToEndId> XYZ456 </EndToEndId>	Unique reference number of transaction (assigned by initiating party) Related reference
	<Amt> ▶ <InstAmt> 500.00 </Amt>	Amount
	<FnlAgt> ▶ <BIC> SBANKFACXXX </BIC>	BIC of Settlement Bank of Interfaced AS
	<DmstAcct> ▶ <Id> SUBACC12349 </Id>	Credited sub-account number
	<Rmlnf> ▶ <Unstrd> HKL1234 </Unstrd>	Information from ordering institution to final beneficiary
	<RsltBal> ▶ <Amt>1000.00</Amt> ▶ <CdtDbtInd>CRDT</CdtDbtInd> ▶ <ValDt> <DtTm>2007-01-01T09:00:00	Resulting balance in the credited sub-account

2 Flow of payments/transactions

2.4 AS transactions

2.4.7 Cross-DvP: Settlement on dedicated liquidity account

④ MT 910 (optional) from ASI to Settlement Bank (Final Agent)	S: TRGTXEPMASI	TRGTXEPMASI
	R: SBANKFACXXX	BIC of credited account
	20: AS123456789	TRN by SSP
	21: XYZ456	Copy of EndToEndIdentification of initial ASTransferInitiation
	25: SUBACC12349	Credited sub-account
	32A: 500.00	Amount debited/credited
	52a: BICASGRAXXX	BIC of sender AS
	72: /ASCRED/	Creditor from ① (if filled)
	72: /ASINF/HKL1234	RemittanceInformation from ① (if filled)

BIC Integrated AS: BICASGRAXXX

BIC Interfaced AS: BICASFACXXX

BIC of Integrated AS mirror account: MIRROGRAXXX

BIC of Settlement Bank of Integrated AS: SBANKGRAXXX

BIC of Settlement Bank of Interfaced AS: SBANKFACXXX

2 Flow of payments/transactions

2.4 AS transactions

2.4.7 Cross-DvP: Settlement on dedicated liquidity account

2.4.7.2 From Integrated AS to Integrated AS

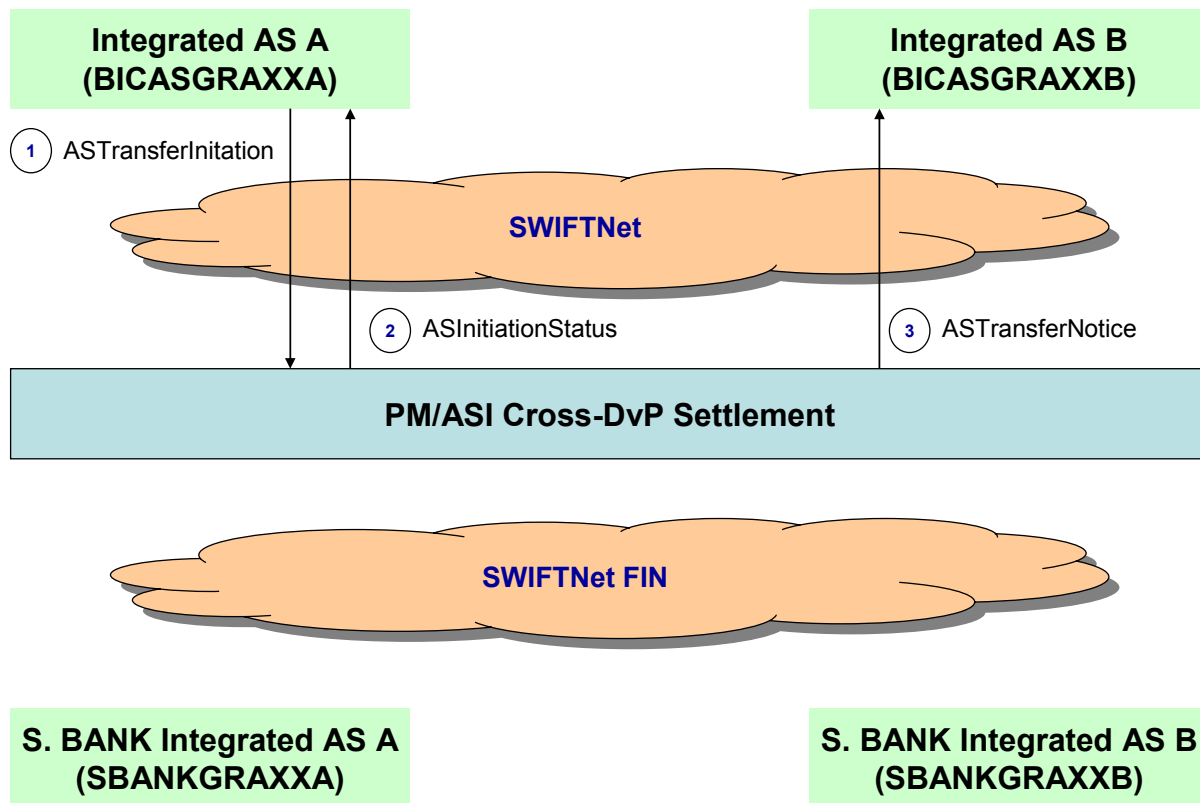

Message	Tag/field of message	Field entry
① ASTransferInitiation from Integrated AS A (or its CB on its behalf) to ASI	<Grpld> ABCDE1234 </Grpld>	Unique ID for the file (assigned by sender)
	<InitgPty> ▶<BIC> BICASGRAXXA </BIC>	BIC of AS if CB sends this message on its behalf – Initiating Party
	<CtpAS> ▶<BIC> BICASGRAXXB </BIC>	BIC of Counterpart AS
	<PmtSchme> <Cd> CDS </Cd>	Payment Scheme Code for cross-DVP settlement
	<Dbtr> ▶<Id> SBANKGRAXXA </Id>	Debtor. BIC of Settlement Bank of Integrated AS
	<FrstAgt> ▶<BIC> MIRROGRAXXA </BIC>	BIC of mirror account of Integrated AS A

2 Flow of payments/transactions

2.4 AS transactions

2.4.7 Cross-DvP: Settlement on dedicated liquidity account

	<p><PmtTx> ▶ <PmtId> ▶ <InstrId>ABC1234</InstrId> ▶ <EndToEndId>XYZ456</EndToEndId></p>	<p>Unique reference number of transaction (assigned by initiating party) Related reference</p>
	<p><Amt> ▶ <InstAmt>500.00</Amt></p>	Amount
	<p><Cdtr> ▶ <Id>SBANKGRAXXB</Id></p>	Creditor. BIC of Settlement Bank of Integrated AS B
	<p><FnlAgt> ▶ <BIC>MIRROGRAXXB</BIC></p>	BIC of Settlement Bank of Integrated AS B
	<p><Rmlnf> ▶ <Unstrd>HKL1234</Unstrd></p>	Information from ordering institution to final beneficiary
② ASInitiationStatus from ASI to Ancillary System	<p><Grpld>ABCDE1234</Grpld></p>	Unique ID of initial ASTransferInitiation
③ ASTransferNotice from ASI to Integrated AS B	<p><CtpAS> ▶ <BIC>BICASFACXXXA</BIC></p>	BIC of Counterpart AS (sender of the ASTransferInitiation)
	<p><PmtSchme> <Cd>CDS</Cd></p>	Payment Scheme Code for cross-DVP settlement
	<p><Dbtr> ▶ <Id>SBANKGRAXXA</Id></p>	Debtor. BIC of Settlement Bank of Integrated AS
	<p><FrstAgt> ▶ <BIC>MIRROGRAXXX</BIC></p>	BIC of mirror account of Integrated AS
	<p><DmstAcct> ▶ <Id>SUBACC12340</Id></p>	Debited sub-account number
	<p><PmtTx> ▶ <PmtId> ▶ <InstrId>ABC1234</InstrId> ▶ <EndToEndId>XYZ456</EndToEndId></p>	<p>Unique reference number of transaction (assigned by initiating party) Related reference</p>
	<p><Amt> ▶ <InstAmt>500.00</Amt></p>	Amount
	<p><Cdtr> ▶ <Id>SBANKGRAXXB</Id></p>	Creditor. BIC of Settlement Bank of Integrated AS B
	<p><FnlAgt> ▶ <BIC>MIRROGRAXXB</BIC></p>	BIC of Settlement Bank of Integrated AS B
	<p><Rmlnf> ▶ <Unstrd>HKL1234</Unstrd></p>	Information from ordering institution to final beneficiary

2 Flow of payments/transactions

2.4 AS transactions

2.4.7 Cross-DvP: Settlement **on dedicated liquidity account**

	<pre><RsltgBal> ▶<Amt>1000.00</Amt> ▶<CdtDbtInd>CRDT</CdtDbtInd> ▶<ValDt> <DtTm>2007-01-01T09:00:00</pre>	Resulting balance in the credited sub-account
--	---	---

BIC Integrated AS A: BICASGRAXXA

BIC Integrated AS B: BICASGRAXXB

BIC of Integrated AS A mirror account: MIRROGRAXXA

BIC of Integrated AS B mirror account: MIRROGRAXXB

BIC of Settlement Bank of Integrated AS A: SBANKGRAXXA

BIC of Settlement Bank of Interfaced AS B: SBANKGRAXXB

2 Flow of payments/transactions

2.4 AS transactions

2.4.7 Cross-DvP: Settlement on dedicated liquidity account

2.4.7.3 From Interfaced AS to Integrated AS

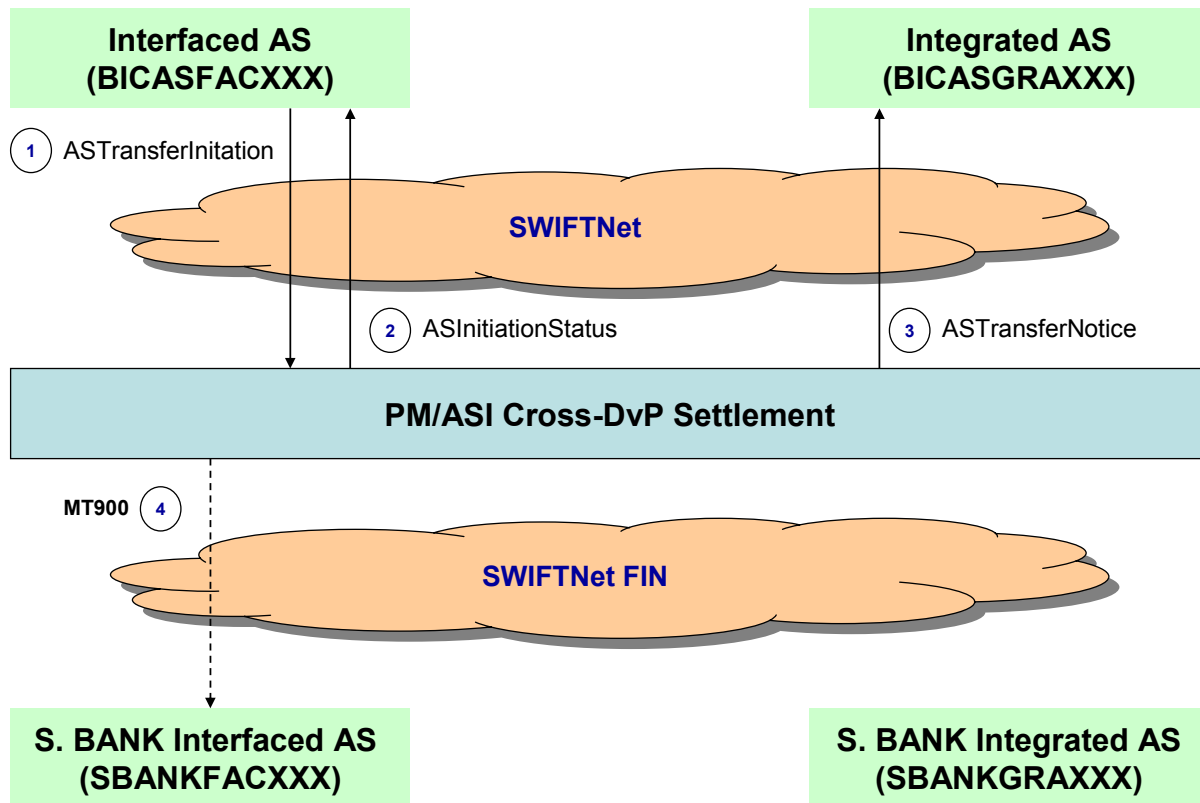

Message	Tag/field of message	Field entry
① ASTransferInitiation from Integrated AS (or Its CB on its behalf) to ASI	<Grpld> ABCDE1234 </Grpld>	Unique ID for the file (assigned by sender)
	<InitgPty> ▶ <BIC> BICASFACXXX </BIC>	BIC of AS if CB sends this message on its behalf – Initiating Party
	<CtpAS> ▶ <BIC> BICASGRAXXX </BIC>	BIC of Counterpart AS
	<PmtSchme> <Cd> CDS </Cd>	Payment Scheme Code for cross-DVP settlement
	<FrstAgt> ▶ <BIC> SBANKFACXXX </BIC>	BIC of Settlement Bank of Interfaced AS
	<DmstAcct> ▶ <Id> SUBACC1234 </Id>	Sub-account to be debited

2 Flow of payments/transactions

2.4 AS transactions

2.4.7 Cross-DvP: Settlement on dedicated liquidity account

	<PmtTx> ▶ <PmtId> ▶ <InstrId> ABC1234 </InstrId> ▶ <EndToEndId> XYZ456 </EndToEndId>	Unique reference number of transaction (assigned by initiating party) Related reference
	<Amt> ▶ <InstAmt> 500.00 </Amt>	Amount
	<FnlAgt> ▶ <BIC> MIRROGRAXXX </BIC>	BIC of mirror account of Integrated AS
	<Cdtr> ▶ <Id> SBANKGRAXXX </Id>	BIC of Settlement Bank of Integrated AS
	<Rmlnf> ▶ <Unstrd> HKL1234 </Unstrd>	Information from ordering institution to final beneficiary
② ASInitiationStatus from ASI to Ancillary System	<Grpld> ABCDE1234 </Grpld>	Unique ID of initial ASTransferInitiation
③ ASTransferNotice from ASI to Integrated AS	<CtpAS> ▶ <BIC> BICASFACXXX </BIC>	BIC of Counterpart AS (sender of the ASTransferInitiation)
	<PmtSchme> <Cd> CDS </Cd>	Payment Scheme Code for cross-DVP settlement
	<FrstAgt> ▶ <BIC> SBANKFACXXA </BIC>	BIC of Settlement Bank of Integrated AS
	<DmstAcct> ▶ <Id> SUBACC12340 </Id>	Debited sub-account number
	<PmtTx> ▶ <PmtId> ▶ <InstrId> ABC1234 </InstrId> ▶ <EndToEndId> XYZ456 </EndToEndId>	Unique reference number of transaction (assigned by initiating party) Related reference
	<Amt> ▶ <InstAmt> 500.00 </Amt>	Amount
	<Cdtr> SBNKGRAXXX </Cdtr>	Creditor. BIC of Settlement Bank of Integrated AS
	<FnlAgt> ▶ <BIC> MIRROGRAXXX </BIC>	BIC of mirror account of Integrated AS
	<Rmlnf> ▶ <Unstrd> HKL1234 </Unstrd>	Information from ordering institution to final beneficiary

2 Flow of payments/transactions

2.4 AS transactions

2.4.7 Cross-DvP: Settlement on dedicated liquidity account

	<RsltGBal> ▶ <Amt>1000.00</Amt> ▶ <CdtDbtInd>CRDT</CdtDbtInd> ▶ <ValDt> <DtTm>2007-01-01T09:00:00	Resulting balance in the credited mirror account
④ MT 900 (optional) from ASI to Settlement Bank (Final Agent)	S: TRGTXEPMASI	TRGTXEPMASI
	R: SBANKFACXXX	BIC of debited account
	20: AS123456789	TRN by SSP
	21: XYZ456	Copy of EndToEndIdentification of initial ASTransferInitiation
	25: SUBACC12349	Debited sub-account
	32A: 500.00	Amount debited/credited
	52a: BICASFACXXX	BIC of sender AS
	72: /ASDEBT/	Debtor from ① (if filled)
	72: /ASINF/HKL1234	RemittanceInformation from ① (if filled)

BIC Integrated AS: BICASGRAXXX

BIC Interfaced AS: BICASFACXXX

BIC of Integrated AS mirror account: MIRROGRAXXX

BIC of Settlement Bank of Integrated AS: SBANKGRAXXX

BIC of Settlement Bank of Interfaced AS: SBANKFACXXX

2 Flow of payments/transactions

2.4 AS transactions

2.4.7 Cross-DvP: Settlement on dedicated liquidity account

2.4.7.4 From Interfaced AS to Interfaced AS

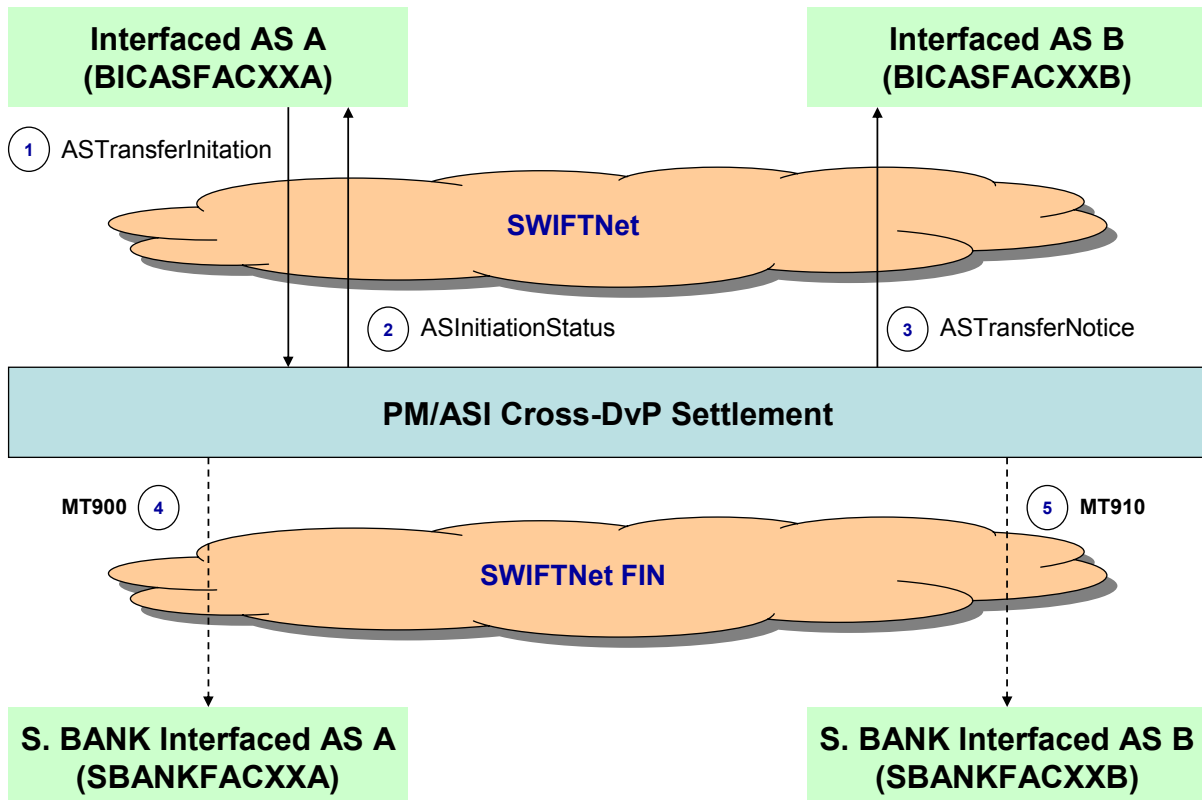

Message	Tag/field of message	Field entry
① ASTransferInitiation from Interfaced AS A (or Its CB on its behalf) to ASI	<Grpld> ABCDE1234 </Grpld>	Unique ID for the file (assigned by sender)
	<InitgPty> ▶ <BIC> BICASFACXXA </BIC>	BIC of AS if CB sends this message on its behalf – Initiating Party
	<CtpAS> ▶ <BIC> BICASFACXXB </BIC>	BIC of Counterpart AS
	<PmtSchme> <Cd> CDS </Cd>	Payment Scheme Code for cross-DVP settlement
	<FrstAgt> ▶ <BIC> SBANKFACXXA </BIC>	BIC of Settlement Bank of Interfaced AS
	<DmstAcct> ▶ <Id> SUBACC12340 </Id>	Sub-account to be debited
	<PmtTx> ▶ <PmtId> ▶ <InstrId> ABC1234 </InstrId>	Unique reference number of transaction (assigned by initiating party)

2 Flow of payments/transactions

2.4 AS transactions

2.4.7 Cross-DvP: Settlement on dedicated liquidity account

	▶ <EndToEndId> XYZ456 </EndToEndId>	Related reference
	<Amt> ▶ <InstAmt> 500.00 </InstAmt>	Amount
	<FnlAgt> ▶ <BIC> SBANKFACXXB </BIC>	BIC of mirror account of Integrated AS
	<DmstAcct> ▶ <Id> SUBACC12349 </Id>	Credited sub-account number
	<Rmlnf> ▶ <Unstrd> HKL1234 </Unstrd>	Information from ordering institution to final beneficiary
② ASInitiationStatus from ASI to Ancillary System	<Grpld> ABCDE1234 </Grpld>	Unique ID of initial ASTransferInitiation
③ ASTransferNotice to Interfaced AS B	<CtpAS> ▶ <BIC> BICASFACXXXA </BIC>	BIC of Counterpart AS (sender of the ASTransferInitiation)
	<PmtSchme> <Cd> CDS </Cd>	Payment Scheme Code for cross-DVP settlement
	<FrstAgt> ▶ <BIC> SBANKFACXXA </BIC>	BIC of Settlement Bank of Interfaced AS
	<DmstAcct> ▶ <Id> SUBACC12340 </Id>	Debited sub-account number
	<PmtTx> ▶ <PmtId> ▶ <InstrId> ABC1234 </InstrId>	Unique reference number of transaction (assigned by initiating party)
	▶ <EndToEndId> XYZ456 </EndToEndId>	Related reference
	<Amt> ▶ <InstAmt> 500.00 </InstAmt>	Amount
	<FnlAgt> ▶ <BIC> SBANKFACXXB </BIC>	BIC of Settlement Bank of Interfaced AS
	<DmstAcct> ▶ <Id> SUBACC12349 </Id>	Sub-account to be credited
	<Rmlnf> ▶ <Unstrd> HKL1234 </Unstrd>	Information from ordering institution to final beneficiary
	<RsltGbal> ▶ <Amt>1000.00</Amt> ▶ <CdtDbtInd>CRDT</CdtDbtInd> ▶ <ValDt> <DtTm>2007-01-01T09:00:00	Resulting balance in the credited sub-account
④ MT 900 (optional) from ASI to Settlement Bank	S: TRGTXEPMASI	TRGTXEPMASI

2 Flow of payments/transactions

2.4 AS transactions

2.4.7 Cross-DvP: Settlement on dedicated liquidity account

(Final Agent)		
	R: SBANKFACXXA	BIC of debited account
	20: AS123456789	TRN by SSP
	21: XYZ456	Copy of EndToEndIdentification of initial ASTransferInitiation
	25: SUBACC12340	Debited sub-account
	32A: 500.00	Amount debited/credited
	52a: BICASFACXXA	BIC of sender AS
	72: /ASDEBT/	Debtor from ① (if filled)
	72: /ASINF/HKL1234	RemittanceInformation from ① (if filled)
⑤ MT 910 (optional) from ASI to Settlement Bank (Final Agent)	S: TRGTXEPMASI	TRGTXEPMASI
	R: SBANKFACXXB	BIC of credited account
	20: AS987654321	TRN by SSP
	21: XYZ456	Copy of EndToEndIdentification of initial ASTransferInitiation
	25: SUBACC12349	Credited sub-account
	32A: 500.00	Amount debited/credited
	52a: BICASGRAXXX	BIC of sender AS
	72: /ASCRED/	Creditor from ① (if filled)
	72: /ASINF/HKL1234	RemittanceInformation from ① (if filled)

BIC Interfaced AS A: BICASFACXXA

BIC Interfaced AS B: BICASFACXXB

BIC of Settlement Bank of Interfaced AS A: SBANKFACXXA

BIC of Settlement Bank of Interfaced AS B: SBANKFACXXB

2 Flow of payments/transactions

2.5 Backup payments

2.5.1 Backup lump-sum payment to a direct PM participant (including CBs as direct PM participant)

2.5 Backup payments

2.5.1 Backup lump-sum payment to a direct PM participant (including CBs as direct PM participant)

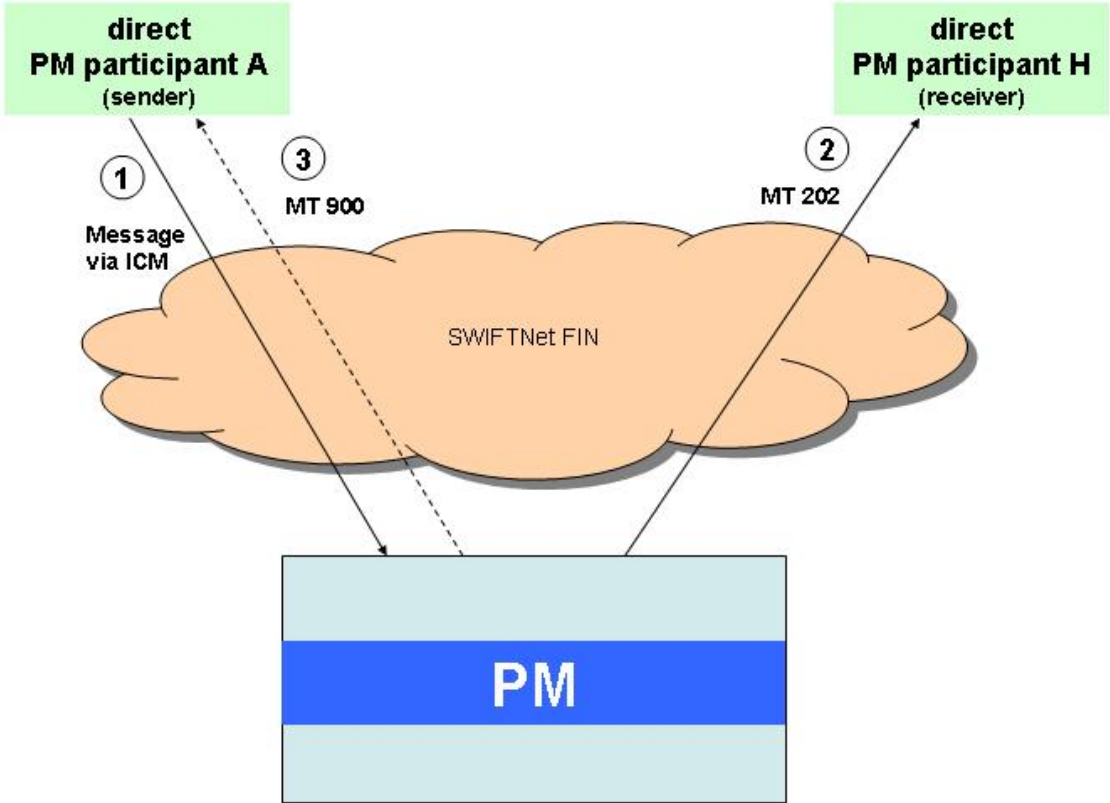

Message	BIC of respective SSP-Module	Field entry
① Message via ICM		
② MT 202 to direct PM participant	TRGTXEPMXXX (SSP-BIC of PM)	S: TRGTXEPMXX R: Direct PM participant H (receiver)
		20: TRN by SSP 21: Related Reference

2 Flow of payments/transactions

2.5 Backup payments

2.5.1 Backup lump-sum payment to a direct PM participant (including CBs as direct PM participant)

Message	BIC of respective SSP-Module	Field entry
		32A: Value date, currency code and amount ... 52a: Direct PM participant A (sender) 58a: Direct PM participant H (receiver) ... 72: /BUP/
③ MT 900 (<i>optional</i>) from PM to direct PM participant (sender)	TRGTXEPMXXX (SSP-BIC of PM)	S: TRGTXEPMXXX R: Direct PM participant A (sender)
		20: TRN by SSP 21: Field 20 (TRN) of initial MT 202 25: Account of direct PM participant H (debited) ... 32A: Value date, currency code and amount ... 52a: Direct PMM participant A (sender) ... 72: /BUP/

2 Flow of payments/transactions

2.5 Backup payments

2.5.2 Backup Contingency payments

2.5.2 Backup Contingency payments

2.5.2.1 Rules for CLS payments

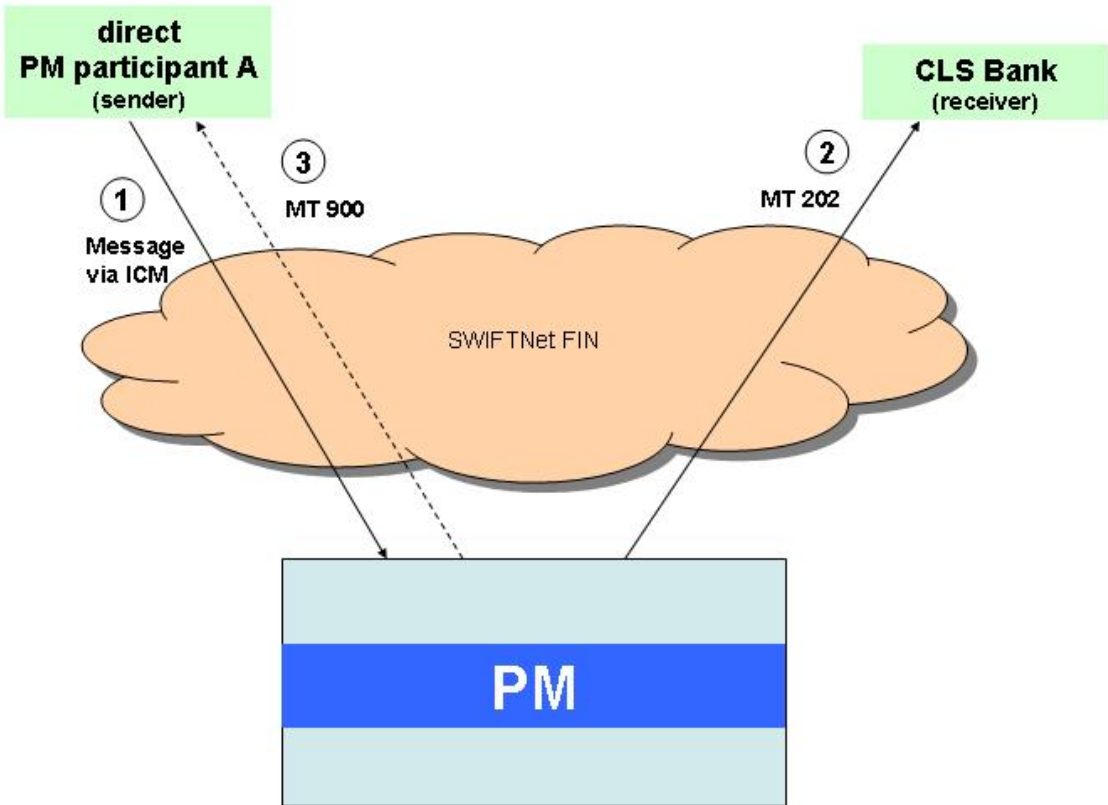

Message	BIC of respective SSP-Module	Field entry
① Message via ICM		
② MT 202 to CLS Bank	TRGTXEPMXXX (SSP-BIC of PM)	S: TRGTXEPMXXX R: CLSBUS33XXX (CLS Bank)

2 Flow of payments/transactions

2.5 Backup payments

2.5.2 Backup Contingency payments

Message	BIC of respective SSP-Module	Field entry
		20: TRN by PM 21: Related Reference 32A: Value date, currency code and amount ... 52a: Direct PM participant A (sender) ... 57A: CLSBUS33XXX (receiver) 58A: Direct PM participant A (beneficiary) ... 72: /BUP/ /CLSTIME/hhmm
③ MT 900 (<i>optional</i>) from PM to direct PM participant (sender)	TRGTXEPMXXX (SSP-BIC of PM)	S: TRGTXEPMXXX R: Direct PM participant A (sender) ... 20: TRN by SSP 21: Field 20 (TRN) of initial MT 202 25: Account of direct PM participant A (debited) ... 32A: Value date, currency code and amount ... 52a: Direct PM participant A (sender) ... 72: /BUP/

2 Flow of payments/transactions

2.5 Backup payments

2.5.2 Backup Contingency payments

2.5.2.2 Rules for payments to EBA related to EURO1

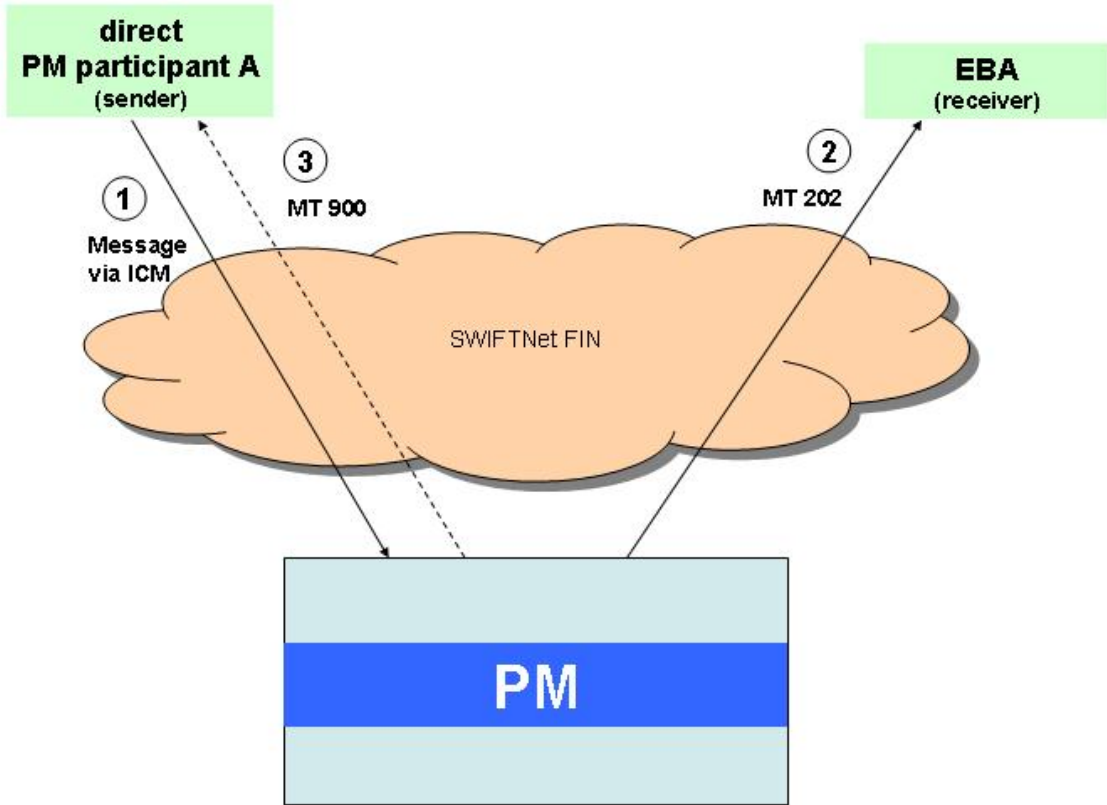

Message	BIC of respective SSP-Module	Field entry
① Message via ICM		
② MT 202 to EBA	TRGTXEPMXXX (SSP-BIC of PM)	S: TRGTXEPMXXX R: EBAPFRPPCOL (EBA – EURO1) 20: TRN by PM 21: Related Reference 32A: Value date, currency code and amount ...

2 Flow of payments/transactions

2.5 Backup payments

2.5.2 Backup Contingency payments

Message	BIC of respective SSP-Module	Field entry
		52A: Direct PM participant A (sender) ... 58A: EBAPFRPPCOL (receiver) ... 72: /BUP/
③ MT 900 (optional) from PM to direct PM participant A (sender)	TRGTXEPMXXX (SSP-BIC of PM)	S: TRGTXEPMXXX R: Direct PM participant A (sender) 20: TRN by SSP 21: Field 20 (TRN) of initial MT 202 25: Account of direct PM participant A (debited) ... 32A: Value date, currency code and amount ... 52a: Direct PM participant A (sender) ... 72: /BUP/

2 Flow of payments/transactions

2.5 Backup payments

2.5.2 Backup Contingency payments

2.5.2.3 Rules for payments to EBA related to STEP2

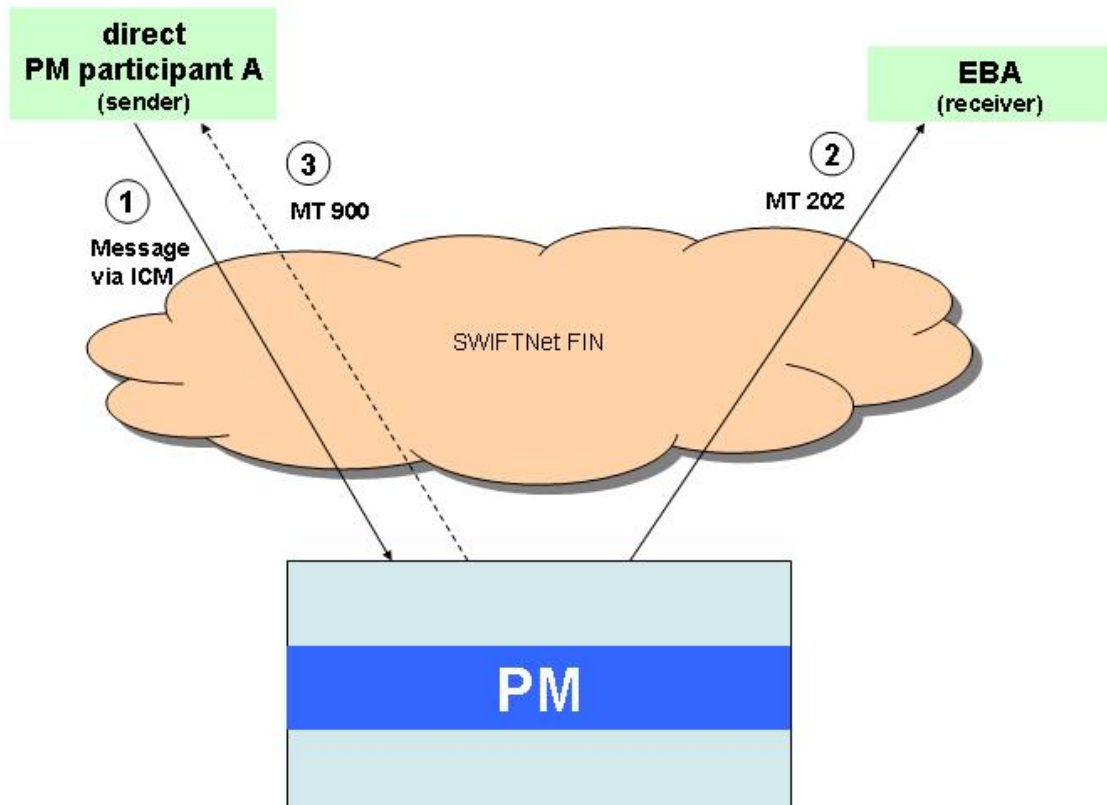

Message	BIC of respective SSP-Module	Field entry
① Message via ICM		
② MT 202 to EBA	TRGTXEPMXXX (SSP-BIC of PM)	S: TRGTXEPMXXX R: EBAPFRPPPSA (EBA – STEP2)

2 Flow of payments/transactions

2.5 Backup payments

2.5.2 Backup Contingency payments

Message	BIC of respective SSP-Module	Field entry
		20: TRN by PM 21: Related Reference 32A: Value date, currency code and amount ... 52a: Direct PM participant A (sender) ... 58a: EBAPFRPPSA (receiver) ... 72: /BUP/
③ MT 900 (optional) from PM to direct PM participant (sender)	TRGTXEPMXXX (SSP-BIC of PM)	S: TRGTXEPMXXX R: Direct PM participant A (sender)
		20: TRN by SSP 21: Field 20 (TRN) of initial MT 202 25: Account of direct PM participant A (debited) ... 32A: Value date, currency code and amount ... 52a: Direct PM participant A (sender) ... 72: /BUP/